

53089

 SUPERSEDED

AMPOWER

TE Internal #: 53089

TE Internal Description: SPLICE,AMPOWER BUTT 500MCM

AMPOWER Butt Splice Long Barrel

[View on TE.com >](#)



Terminals & Splices > Splices > AMPOWER Butt Splice Long Barrel



Splice Type: **Butt Splice**

Sealable: **No**

Barrel Inside Diameter: **25.17 mm [.991 in]**

Wire Size: **450000 - 550000 CMA**

[All AMPOWER Butt Splice Long Barrel \(0\)](#)

Features

Product Type Features

Splice Accessory Type	Splice
Splice Type	Butt Splice
Sealable	No
Compatible With Discrete Wire Type	Stranded

Configuration Features

Splice Configuration	Single to Single
Compatible With Wire & Cable Type	Discrete Wire

Body Features

Product Weight	233.686 g
Primary Product Color	Gray

Contact Features

Terminal Plating Thickness	150 µin
Terminal Plating Material	Tin
Contact Base Material	Copper
Barrel Type	Closed

Termination Features

Termination Method to Wire & Cable	Crimp
------------------------------------	-------

Mechanical Attachment

Wire Insulation Support	Without
-------------------------	---------

Dimensions

Barrel Inside Diameter	25.17 mm[.991 in]
Wire Size	450000 - 550000 CMA
Product Length	120.65 mm[4.75 in]

Usage Conditions

Insulation Option	Uninsulated
-------------------	-------------

Operation/Application

Compatible With Wire Base Material	Copper
------------------------------------	--------

Industry Standards

Compatible With Agency/Standards Products	UL
Compatible With Approved Standards Products	UL E13288

Packaging Features

Packaging Quantity	25
Packaging Method	Box

Product Compliance

[For compliance documentation, visit the product page on TE.com>](#)

EU RoHS Directive 2011/65/EU	Compliant
EU ELV Directive 2000/53/EC	Compliant
China RoHS 2 Directive MIIT Order No 32, 2016	No Restricted Materials Above Threshold
EU REACH Regulation (EC) No. 1907/2006	Current ECHA Candidate List: JAN 2024 (240) Candidate List Declared Against: JUNE 2023 (235) Does not contain REACH SVHC
Halogen Content	Not Yet Reviewed for halogen content
Solder Process Capability	Not applicable for solder process capability

Product Compliance Disclaimer

This information is provided based on reasonable inquiry of our suppliers and represents our current actual knowledge based on the information they provided. This information is subject to change. The part numbers that TE has identified as EU RoHS compliant have a maximum concentration of 0.1% by weight in homogenous materials for lead, hexavalent chromium, mercury, PBB, PBDE, DBP, BBP, DEHP, DIBP, and 0.01% for cadmium, or qualify for an exemption to these limits as defined in the Annexes of Directive 2011/65/EU (RoHS2). Finished electrical and electronic equipment products will be CE marked as required by Directive 2011/65/EU. Components may not be CE marked. Additionally, the part

numbers that TE has identified as EU ELV compliant have a maximum concentration of 0.1% by weight in homogenous materials for lead, hexavalent chromium, and mercury, and 0.01% for cadmium, or qualify for an exemption to these limits as defined in the Annexes of Directive 2000/53/EC (ELV). Regarding the REACH Regulation, the information TE provides on SVHC in articles for this part number is based on the latest European Chemicals Agency (ECHA) 'Guidance on requirements for substances in articles' posted at this URL: <https://echa.europa.eu/guidance-documents/guidance-on-reach>

Customers Also Bought



TE Part # DT04-2P
REC, 2P, GRY, N



TE Part # DT06-2S
PLG, 2P, GRY, N



TE Part # W2S
Wedgelocks: DEUTSCH DT



TE Part # 0460-202-16141
DEUTSCH Solid Contacts



TE Part # 282104-1
AMP SUPERSEAL 1.5MM,
CONNECTOR HOUSING

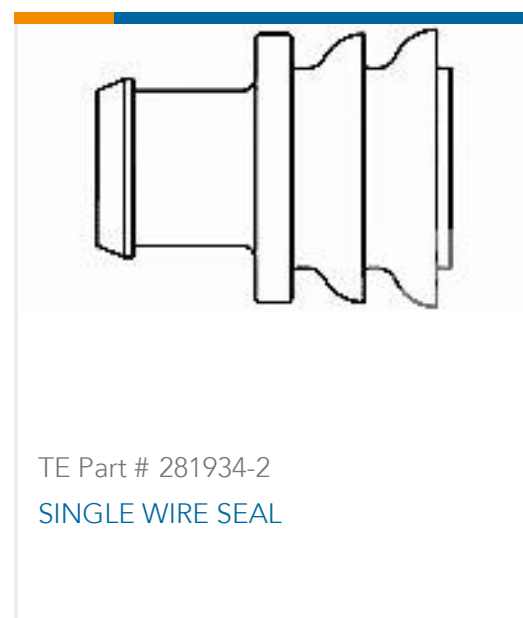

TE Part # 281934-2
SINGLE WIRE SEAL



TE Part # 114017-ZZ
SEALING PLUG, SIZE 12/16, WHT

Documents

CAD Files

3D PDF

3D

Customer View Model

[ENG_CVM_CVM_53089_J.2d_dxf.zip](#)

English

Customer View Model

[ENG_CVM_CVM_53089_J.3d_igs.zip](#)

English

Customer View Model

[ENG_CVM_CVM_53089_J.3d_stp.zip](#)

English

By downloading the CAD file I accept and agree to the [Terms and Conditions](#) of use.

Datasheets & Catalog Pages

[AMPOWER Terminals and Splices Flyer](#)

English

Agency Approvals

[UL Report](#)



English