



[Maxim](#) > [Design Support](#) > [Technical Documents](#) > [Reference Designs](#) > [Amplifier and Comparator Circuits](#) > APP 3680  
[Maxim](#) > [Design Support](#) > [Technical Documents](#) > [Reference Designs](#) > [Video Circuits](#) > APP 3680

Keywords: Direct Drive video amplifier, Reconstruction filter

REFERENCE DESIGN 3680 INCLUDES: ✓Tested Circuit ✓Schematic ✓Description

# Implementation of a DirectDrive Video Filter Amplifier's Negative Charge Pump and Analog Switch in Audio/Video Applications

By: Marvin Li  
Dec 22, 2005

*Abstract: The MAX9503/MAX9505 DirectDrive™ video filter amplifiers integrate an analog switch (MAX9505 only) and a negative charge pump that can be used to improve performance for audio/video applications.*

## Description

The MAX9503/MAX9505 DirectDrive video filter amplifiers integrate an analog switch (MAX9505 only) and a negative charge pump. These devices operate from a single 2.7V to 3.6V power supply. They can be directly connected to the output of the video DAC and set the black level of video signal to ground at its output. They eliminate the extra negative voltage supply and large output DC-blocking capacitors, thus saving cost and board space. The negative charge pump and the analog switch can be used to improve performance in audio/video applications, as discussed in the following text.

## Adjusting the Sync Tip Voltage by Using the Negative Charge Pump

The MAX9503/MAX9505 expect the input sync tip signal to be between 0 to 50mV above ground for the black level at the output be within -0.1V to 0.1V. In some applications, the sync tip level from the video DAC might have an offset greater than 50mV. With this input signal, the black level at the output of the MAX9503/5 might be greater than 100mV. If a ground black level is needed at the output, the circuit in **Figure 1** can be used to level shift the input signal down to adjust the output black level. Assuming the driving load of the video DAC is 150Ω, a 13kΩ resistor is connected between the input and CPV<sub>SS</sub> (-3.3V), the output of the negative charge pump. This resistor-divider network will level shift the input signal down by approximately 40mV. The ripple on the charge pump output is approximately 40mV<sub>P-P</sub>. Using this resistor-divider network, the ripple noise at the video input is less than 0.5mV, which is negligible.

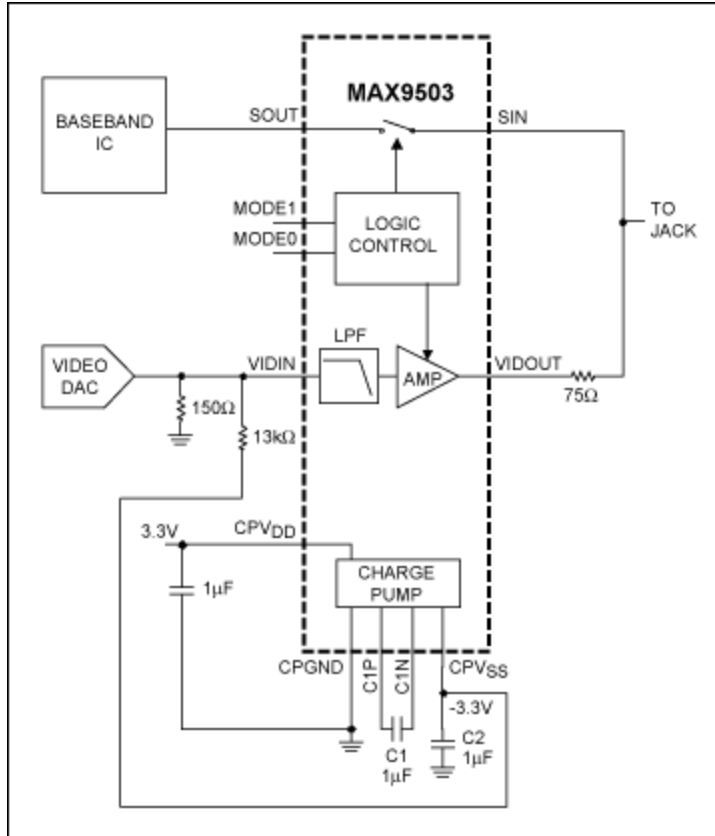

Figure 1. The MAX9503/MAX9505 is used to level shift the input signal down to adjust the output black level.

## Using the Analog Switch for Audio/Video Applications

The MAX9505 integrates an analog switch that interfaces with a four-pole multimedia jack as in **Figure 2**. The video output and the microphone input share the same pin. The operation of the switch can be controlled at the logic level by the MODE0 and MODE1 pins. When the microphone input is used, the switch is closed and the audio signal is passed to the baseband IC through the switch, the video amplifier is disabled, and the output is at high-impedance state. R1 and R2 set the audio bias voltage to be 1.4V. The analog switch has a bandwidth of 200MHz and can be used to switch the video signal. **Figure 3** shows the MAX9505 in bidirectional video input/output application. R3 is the 75Ω termination resistor for the external input video signal.

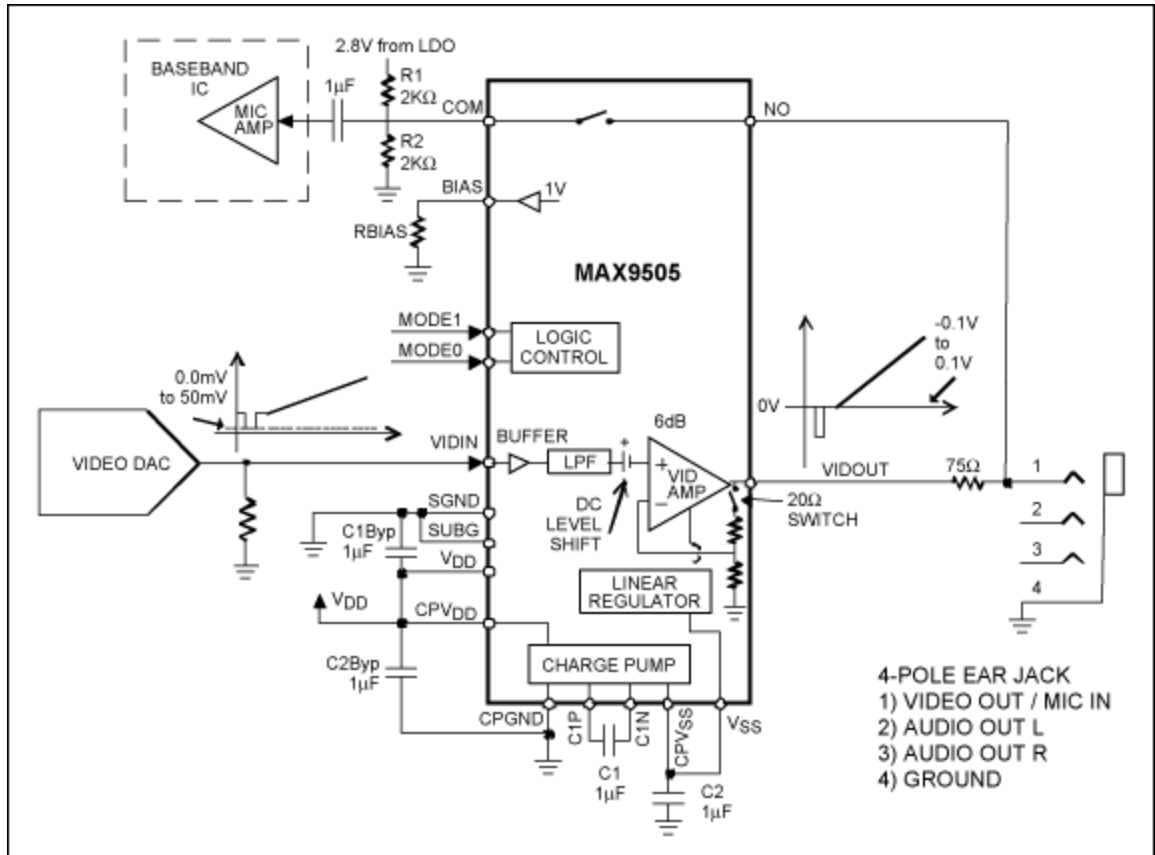

Figure 2. The MAX9505's analog switch interfaces with a four-pole multimedia jack for audio (microphone) input.

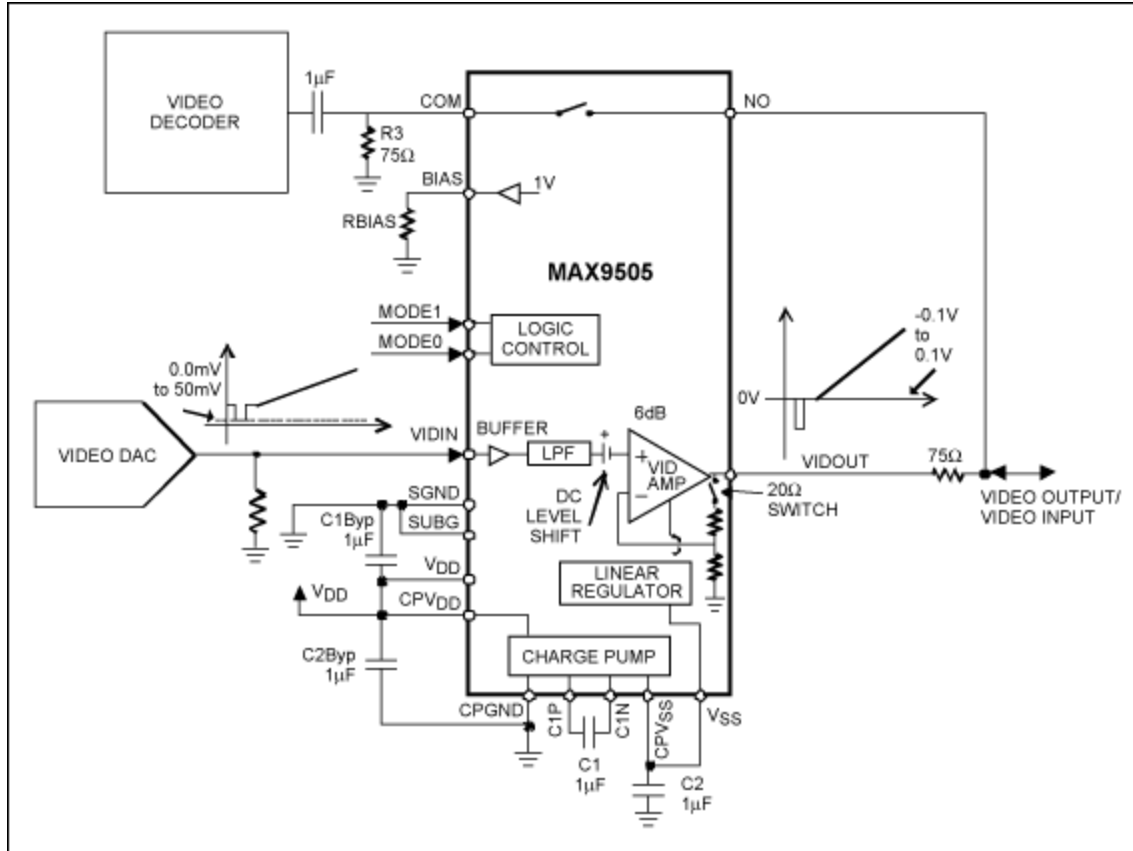

Figure 3. The MAX9505 is used in a bidirectional video input/output application.

DirectDrive is a registered trademark and registered service mark of Maxim Integrated Products, Inc.

#### Related Parts

MAX9503	DirectDrive® Video Amplifier with Reconstruction Filter	<a href="#">Free Samples</a>
MAX9505	DirectDrive Video Amplifier with Reconstruction Filter and Analog Switch	<a href="#">Free Samples</a>

#### More Information

For Technical Support: <http://www.maximintegrated.com/support>

For Samples: <http://www.maximintegrated.com/samples>

Other Questions and Comments: <http://www.maximintegrated.com/contact>

Application Note 3680: <http://www.maximintegrated.com/an3680>

REFERENCE DESIGN 3680, AN3680, AN 3680, APP3680, Appnote3680, Appnote 3680

Copyright © by Maxim Integrated Products

Additional Legal Notices: <http://www.maximintegrated.com/legal>