



Miniature Proportional Valve

Kelly Pneumatics, offers a low volume flow Miniature Proportional Valve utilizing our unique proportional valve design. This non-spool valve architecture employs one moving part, ensuring virtually friction-less control and longevity tested over 100 million cycles. The simplicity of the proportional valve design also ensures relative ease when implementing maintenance or cleaning. We also offer alternative versions that are resistant to both high and low temperatures, therefore performing consistently in many different environments.



Specifications

Valve Function	2 Way, Normally Closed
Electrical Connection	Flying Wire Leads
Working Pressure	-14.7 to 100 psig (6.8 bar) (standard) 500 (psig) (custom)
Flow Range	0 - 500 milliliters of water per minute, 0 - 32 liters per minute of air
Control Voltage	0-5, 0-10 or 0-20 VDC
Port Types	#10 - 32 Inline (Base Mount), 1/16" Manifold Mount
Seal Material	Buna-N, Viton, or EPDM
Operating Temp.	-40° to 200 ° F (-40 ° to 93 ° C)
Maximum Hysteresis	2-10% of full current (varies with max flow)
Leak Rate	Bubble Tight Seal
Weight	0.15 lbs
Filtration	40 Micron Recommended
Power	1.8 watts(max)
Wetted Materials	Cold rolled stainless steel w/ electroless nickel plating, brass and 304 stainless steel

Dimensions

Base Mount Version

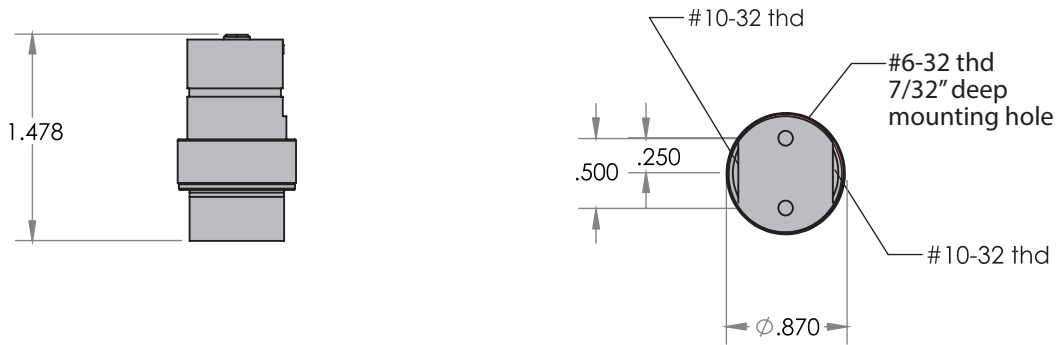

Dimensions

Manifold Mount Version

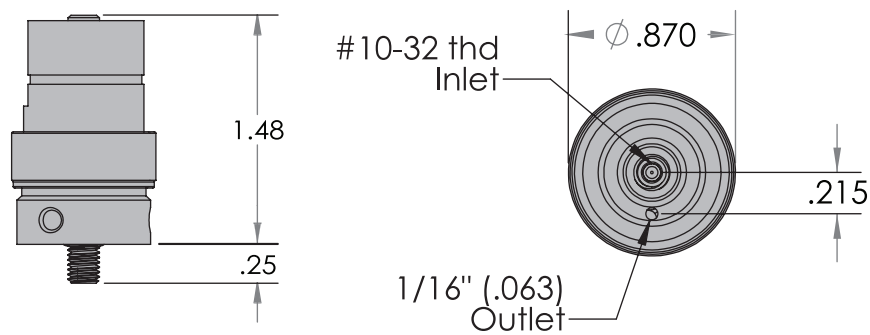

Part Numbering System

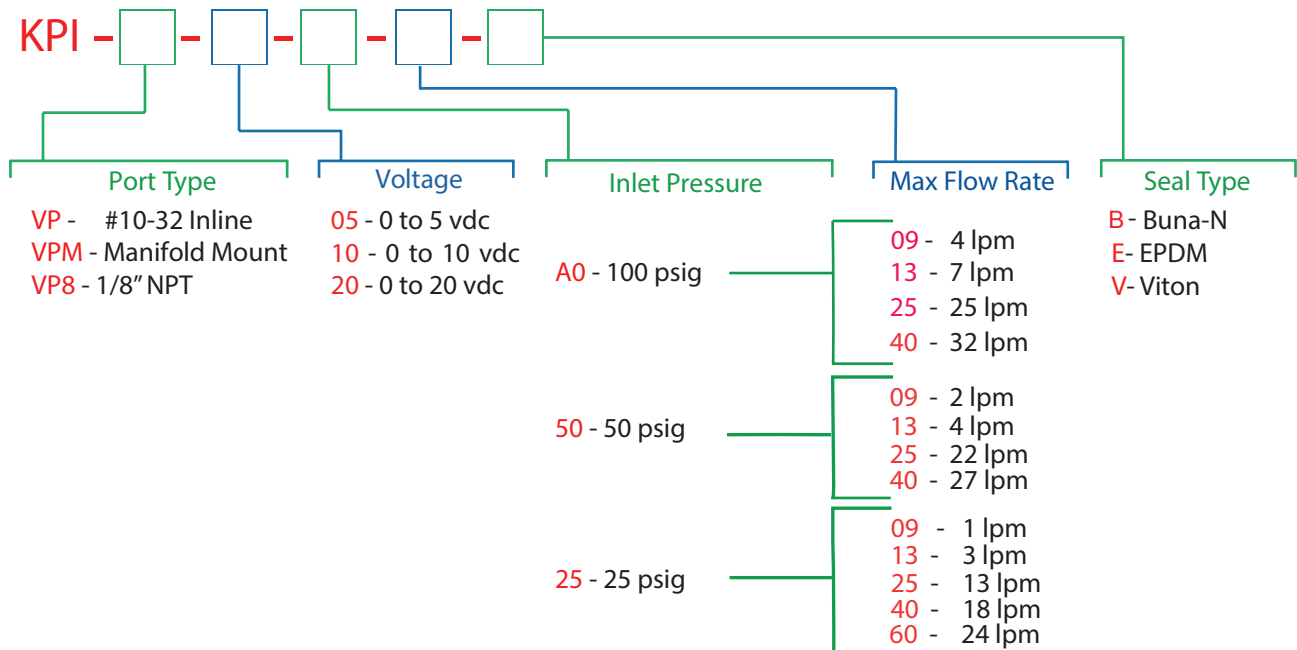

Typical Flow Curve at 25 psig

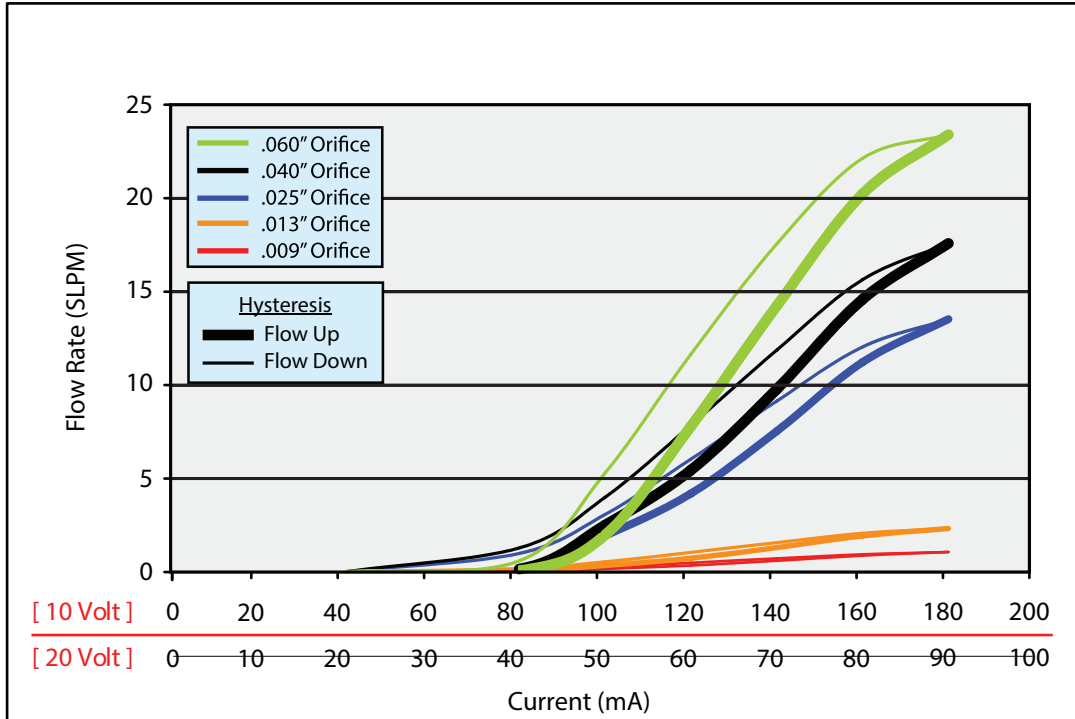

Typical Flow Curve at 50 psig

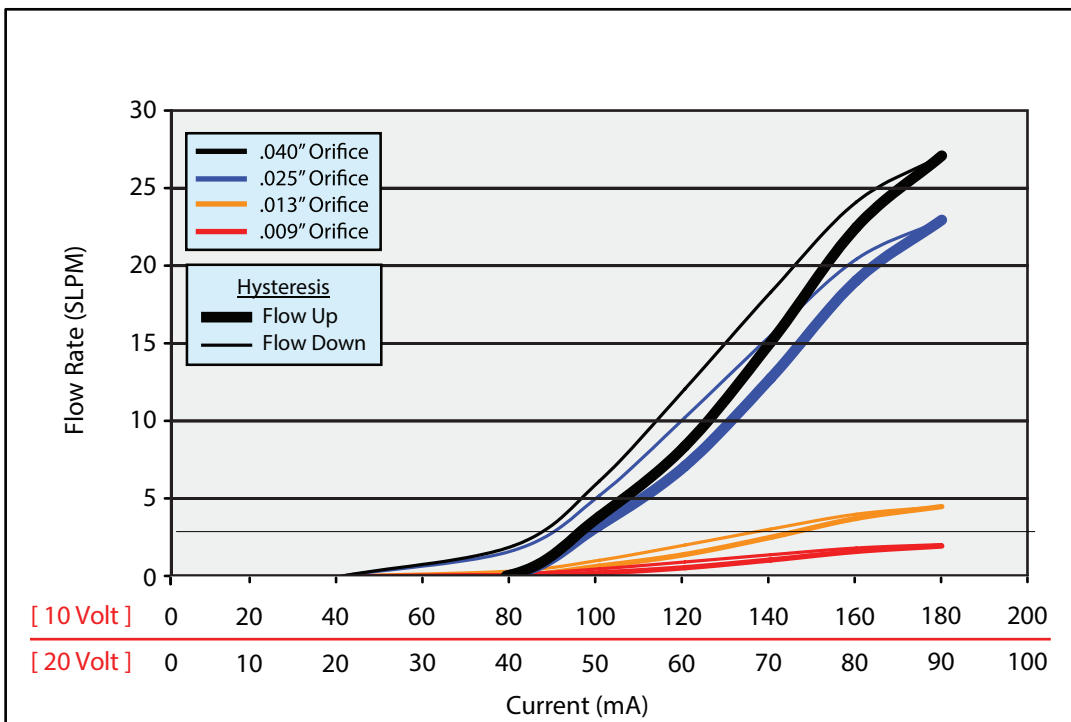

Typical Flow Curve at 100 psig

