

Features

- ESD protection for 1 line with uni-directional
- Provide transient protection for each line to
IEC 61000-4-2 (ESD) $\pm 30\text{kV}$ (air / contact)
IEC 61000-4-4 (EFT) $\pm 80\text{A}$ (5/50ns)
IEC 61000-4-5 (Lightning) 22A (8/20 μs)
- Suitable for, **2.1V and below**, operating voltage applications
- **0201 small MCSP package** saves board space
- Protect one I/O line or one power line
- Fast turn-on and low clamping voltage
- Solid-state silicon-avalanche and active circuit triggering technology
- **Green part**

Applications

- Power supply protection
- OLED displays
- Small panel modules
- Handheld portable applications
- Low speed data or control line protection
- Peripherals
- Consumer electronics

Description

AZ6A21-01M is a design which includes a uni-directional surge rated clamping cell to protect one power line, or one control line, or one low speed data line in an electronic system. The AZ6A21-01M has been specifically designed to protect sensitive components which are connected to power and control lines from

over-voltage damage caused by Electrostatic Discharging (ESD), Electrical Fast Transients (EFT), Lightning, and Cable Discharge Event (CDE).

AZ6A21-01M is a unique design which includes proprietary clamping cell in a single package. During transient conditions, the proprietary clamping cell prevents over-voltage on the power line or control/data lines, protecting any downstream components.

AZ6A21-01M may be used to meet the ESD immunity requirements of IEC 61000-4-2, Level 4 ($\pm 15\text{kV}$ air, $\pm 8\text{kV}$ contact discharge).

Circuit Diagram / Pin Configuration

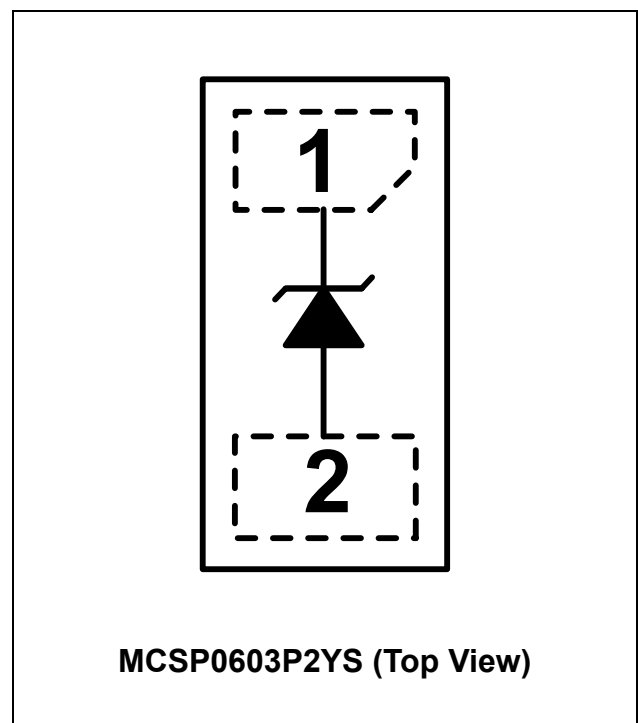



Specifications

| Absolute Maximum Ratings ($T_A = 25^\circ\text{C}$, unless otherwise specified) | | | |
|---|-------------------|---------------|------------------|
| Parameter | Symbol | Rating | Unit |
| Peak Pulse Power ($t_p = 8/20\mu\text{s}$) | P_{PP} (Note 1) | 130 | W |
| Peak Pulse Current ($t_p = 8/20\mu\text{s}$) | I_{PP} (Note 1) | 22 | A |
| ESD per IEC 61000-4-2 (Air) | V_{ESD-1} | ± 30 | kV |
| ESD per IEC 61000-4-2 (Contact) | V_{ESD-2} | ± 30 | |
| Lead Soldering Temperature | T_{SOL} | 260 (10 sec.) | $^\circ\text{C}$ |
| Operating Temperature | T_{OP} | -55 to +125 | $^\circ\text{C}$ |
| Storage Temperature | T_{STO} | -55 to +150 | $^\circ\text{C}$ |

| Electrical Characteristics | | | | | | |
|---------------------------------|----------------|---|-----|------|-----|---------------|
| Parameter | Symbol | Condition | Min | Typ | Max | Unit |
| Reverse Stand-Off Voltage | V_{RWM} | Pin-1 to pin-2, $T = 25^\circ\text{C}$. | | | 2.1 | V |
| Reverse Leakage Current | I_{Leak} | $V_{RWM} = 2.1\text{V}$, $T = 25^\circ\text{C}$, pin-1 to pin-2. | | 0.01 | 0.1 | μA |
| Reverse Breakdown Voltage | V_{BV} | $I_{BV} = 1\text{mA}$, $T = 25^\circ\text{C}$, pin-1 to pin-2. | 2.2 | | 3.6 | V |
| Forward Voltage | V_F | $I_F = 15\text{mA}$, $T = 25^\circ\text{C}$, pin-2 to pin-1. | 0.6 | | 1.2 | V |
| Surge Clamping Voltage (Note 1) | $V_{CL-surge}$ | $I_{PP} = 10\text{A}$, $t_p = 8/20\mu\text{s}$, $T = 25^\circ\text{C}$. | | 4 | | V |
| | | $I_{PP} = 13\text{A}$, $t_p = 8/20\mu\text{s}$, $T = 25^\circ\text{C}$. | | 4.3 | | |
| | | $I_{PP} = 22\text{A}$, $t_p = 8/20\mu\text{s}$, $T = 25^\circ\text{C}$. | | 5.5 | | |
| ESD Clamping Voltage (Note 2) | V_{clamp} | IEC 61000-4-2 +8kV ($I_{TLP} = 16\text{A}$), contact mode, $T = 25^\circ\text{C}$, pin-1 to pin-2. | | 4.4 | | V |
| ESD Dynamic Turn-on Resistance | $R_{dynamic}$ | IEC 61000-4-2 0~+8kV, $T = 25^\circ\text{C}$, contact mode, pin-1 to pin-2. | | 0.1 | | Ω |
| Channel Input Capacitance | C_{IN} | $V_R = 0\text{V}$, $f = 1\text{MHz}$, pin-1 to pin-2, $T = 25^\circ\text{C}$. | | 105 | 135 | pF |

Note 1: The Peak Pulse Current and Peak Pulse Power measured conditions: $t_p = 8/20\mu\text{s}$, 2Ω source impedance.

Note 2: ESD Clamping Voltage was measured by Transmission Line Pulsing (TLP) System.

TLP conditions: $Z_0 = 50\Omega$, $t_p = 100\text{ns}$, $t_r = 1\text{ns}$.

Typical Characteristics

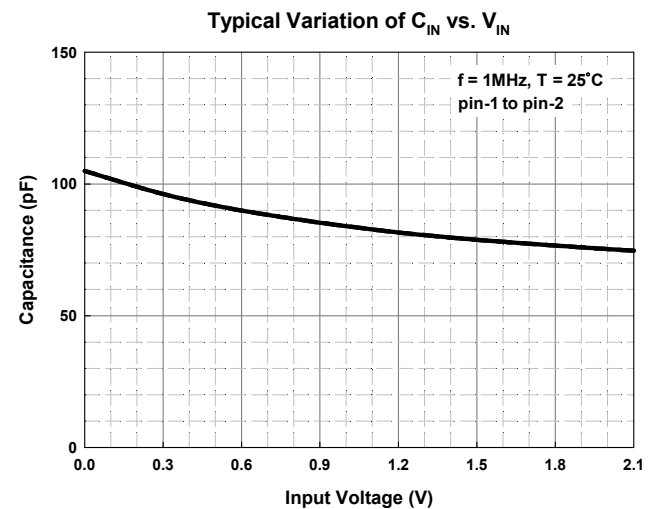
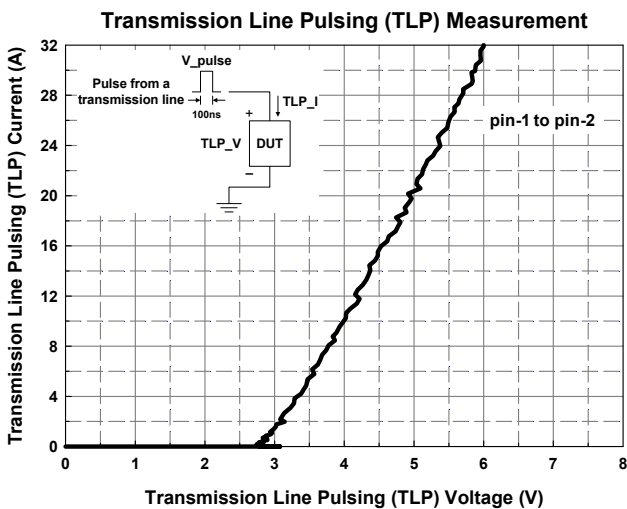
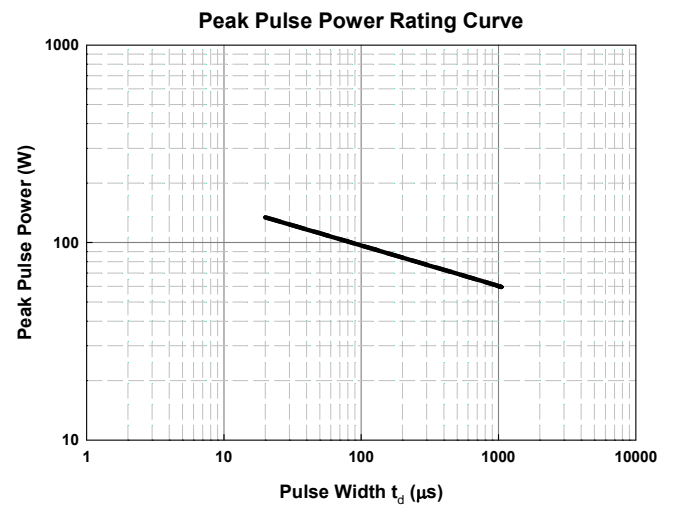
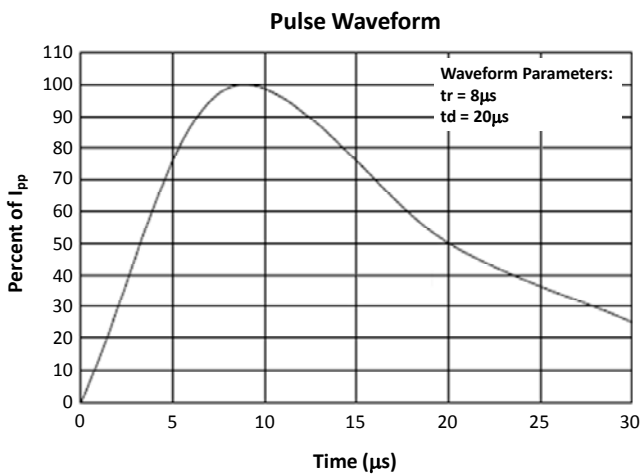
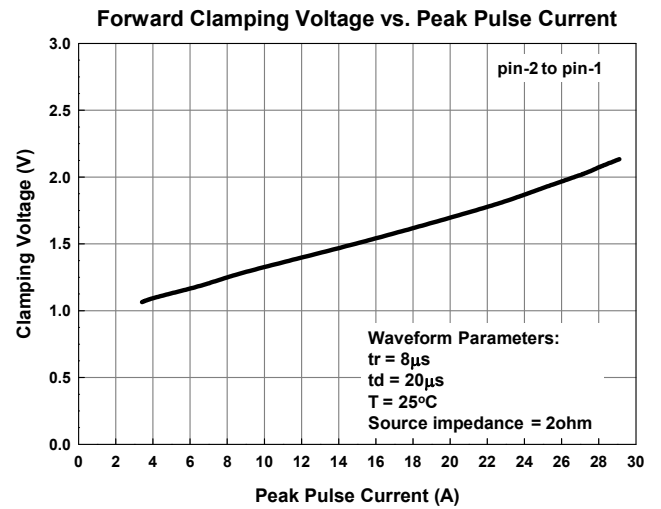
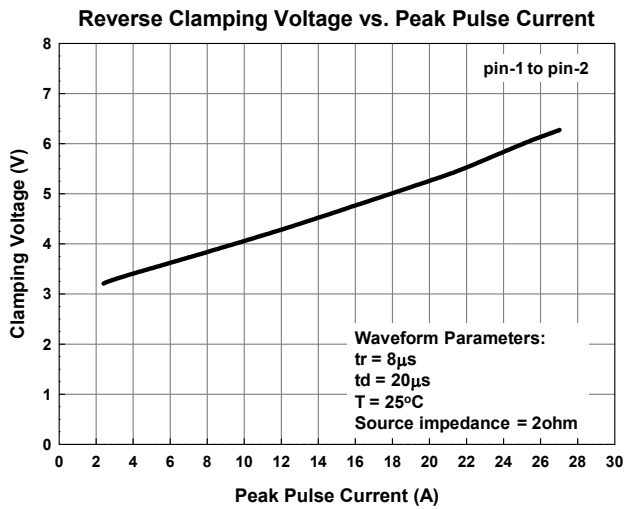

Applications Information

The AZ6A21-01M is designed to protect one line against system ESD / EFT / Lightning pulses by clamping it to an acceptable reference.

The usage of the AZ6A21-01M is shown in Fig. 1. Protected lines, such as data lines, control lines, or power lines, are connected to pin 1. The pin 2 should be connected directly to a ground plane on the board. All path lengths connected to the pins of AZ6A21-01M should be kept as short as possible to minimize parasitic inductance in the board traces.

In order to obtain enough suppression of ESD induced transient, a good circuit board is critical.

Thus, the following guidelines are recommended:

- Minimize the path length between the protected lines and the AZ6A21-01M.
- Place the AZ6A21-01M near the input terminals or connectors to restrict transient coupling.
- The ESD current return path to ground should be kept as short as possible.
- Use ground planes whenever possible.
- NEVER route critical signals near board edges and near the lines which the ESD transient easily injects to.

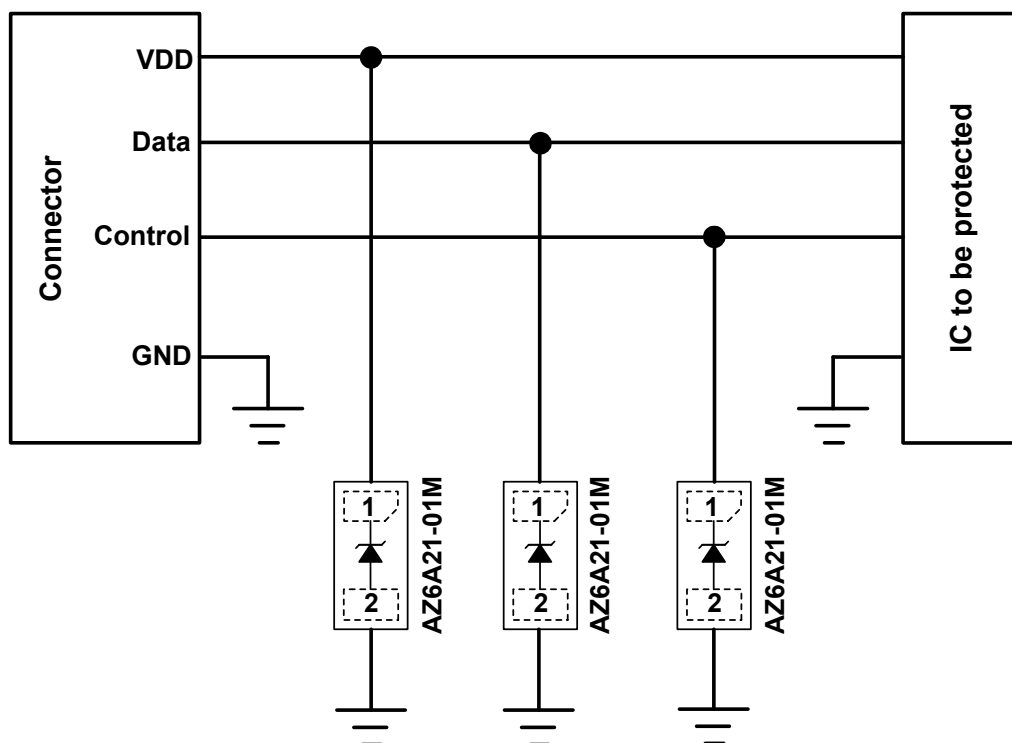
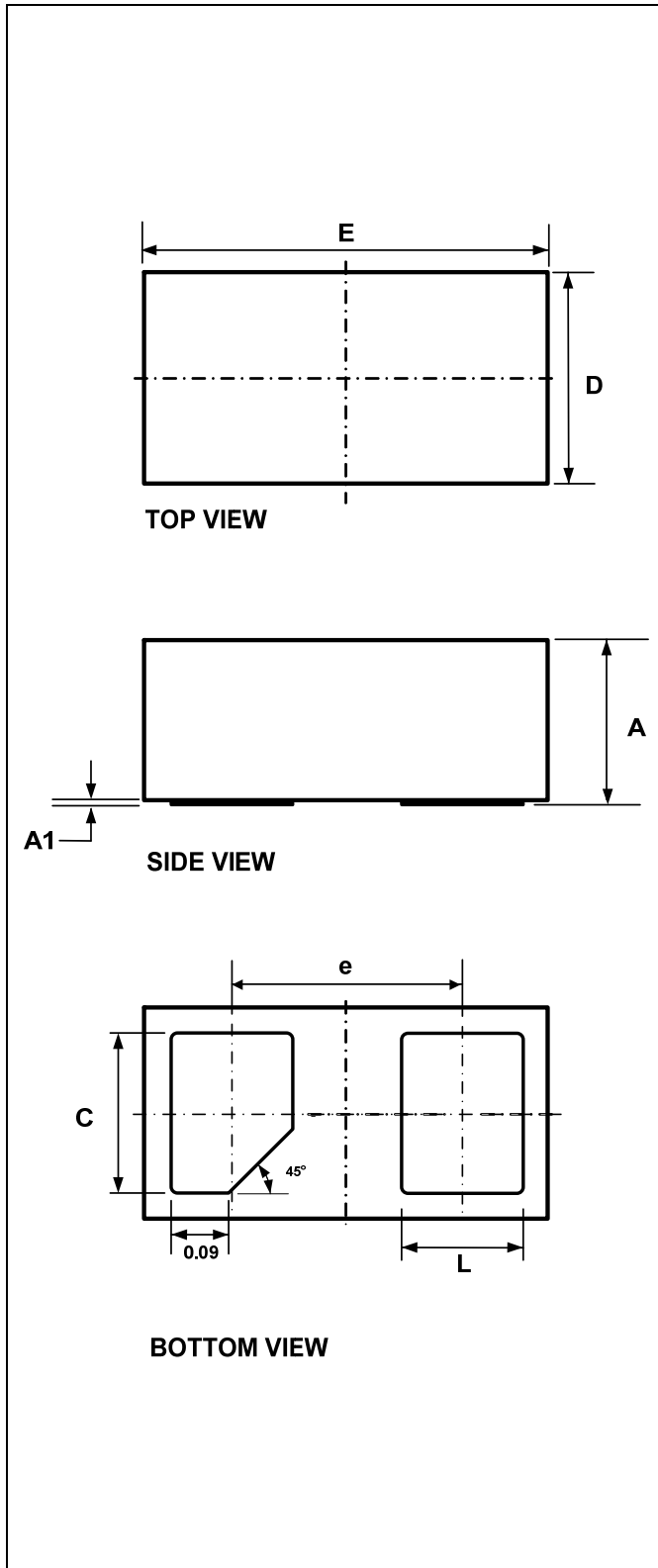

Fig. 1

Mechanical Details

MCSP0603P2YS Package Diagrams



Package Dimensions

| SYMBOL | MILLIMETERS | | |
|--------|-------------|-------|-------|
| | MIN. | NOM. | MAX. |
| E | 0.615 | 0.630 | 0.645 |
| D | 0.315 | 0.330 | 0.345 |
| A | 0.235 | 0.250 | 0.265 |
| A1 | 0.005 | 0.015 | 0.050 |
| L | 0.170 | 0.190 | 0.210 |
| C | 0.230 | 0.250 | 0.270 |
| e | 0.360 BSC | | |

Land Layout

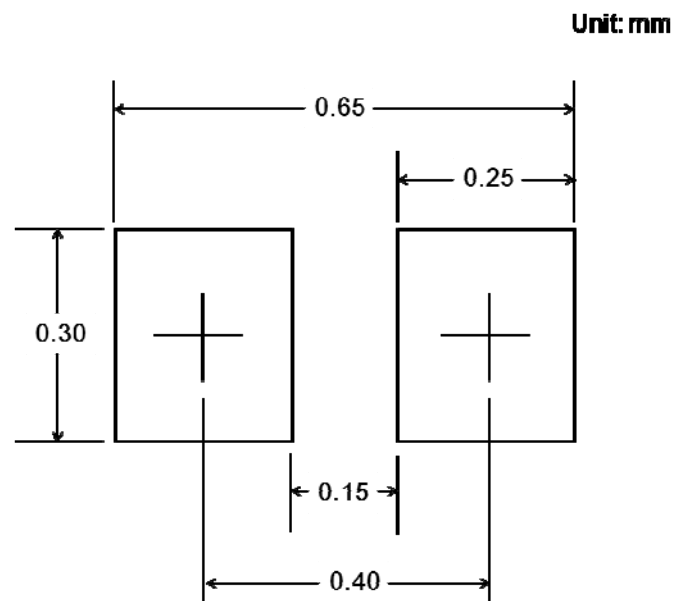

Notes:

This LAND LAYOUT is for reference purposes only. Please consult your manufacturing partners to ensure your company's PCB design guidelines are met.



Marking Code



| Part Number | Marking Code |
|--------------------------------|--------------|
| AZ6A21-01M.R7G (Green Part) | N |

N= Device Code

Note : Green means Pb-free, RoHS, and Halogen free compliant.

Ordering Information

| PN# | Material | Type | Reel size | MOQ | MOQ/internal box | MOQ/carton |
|----------------|----------|------|-----------|-------------|----------------------|--------------------------|
| AZ6A21-01M.R7G | Green | T/R | 7 inch | 15,000/reel | 4 reels = 60,000/box | 6 boxes = 360,000/carton |

Revision History

| Revision | Modification Description |
|---------------------|--------------------------|
| Revision 2022/03/02 | Preliminary Release. |
| Revision 2022/07/07 | Formal Release. |
| | |
| | |
| | |
| | |