

AB356N6T Photocoupler

FEATURES

- High collector-emitter Voltage
- Opaque type, mini-flat package
- Subminiature type (The volume is smaller than that of our conventional DIP type by as far as 30%)
- Isolation voltage between input and output Viso: 3750Vrms
- Employs double transfer mold technology
- Package: 1000 pcs / reel
- Moisture sensitivity level: 4
- RoHS compliant

APPLICATIONS

- Hybrid substrates that require high density mounting
- Programmable controllers

NOTES ON HANDLING

Cautions regarding electrical noise

Please ensure the power supply is stable at all times. Even if the designed operating voltage is within specification limits, sudden voltage spikes at startup may damage the component.

PACKAGE DIMENSIONS

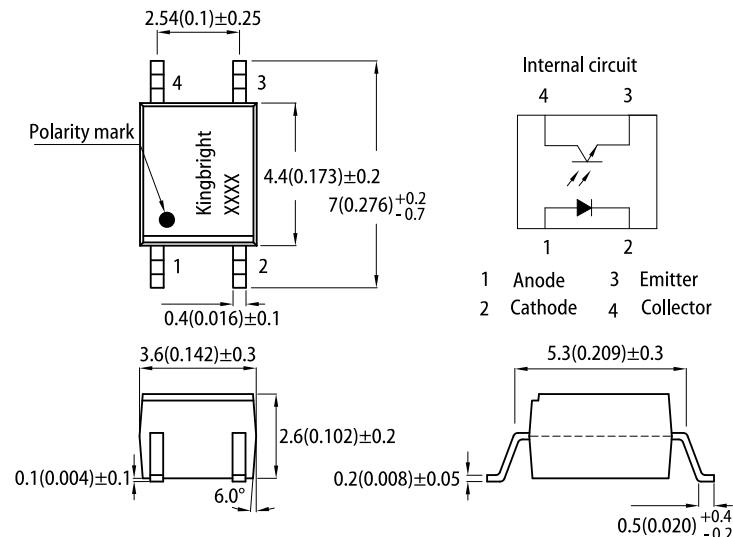

RECOMMENDED SOLDERING PATTERN

(units : mm; tolerance : ± 0.15)

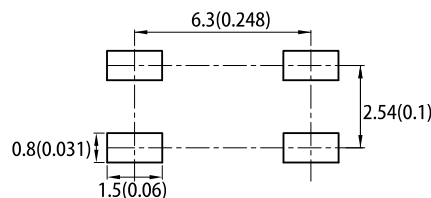

Notes:

1. All dimensions are in millimeters (inches).
2. Tolerance is $\pm 0.5(0.02)$ unless otherwise noted.
3. The specifications, characteristics and technical data described in the datasheet are subject to change without prior notice.
4. The device has a single mounting surface. The device must be mounted according to the specifications.

ELECTRICAL / OPTICAL CHARACTERISTICS at $T_A=25^\circ\text{C}$

Parameter	Symbol	Value			Units	Test Conditions	
		Min.	Typ.	Max.			
Input	Forward voltage	V_F	-	1.2	1.4	V	$I_F=20\text{mA}$
	Peak forward voltage	V_{FM}	-	-	3.0	V	$I_{FM}=0.5\text{A}$
	Reverse current	I_R	-	-	10	μA	$V_R=4\text{V}$
Output	Collector dark current	I_{CEO}	-	-	10^{-7}	A	$I_F=0\text{mA}, V_{CE}=20\text{V}$
	Collector-emitter breakdown voltage	BV_{CEO}	80	-	-	V	$I_F=0\text{mA}, I_C=0.1\text{mA}$
	Emitter-collector breakdown voltage	BV_{ECO}	6	-	-	V	$I_F=0\text{mA}, I_E=10\mu\text{A}$
Transfer characteristics	Current transfer ratio	CTR	130	-	400	%	$I_F=5\text{mA}, V_{CE}=5\text{V}$
	Collector-emitter saturation voltage	$V_{CE(sat)}$	-	0.1	0.2	V	$I_F=20\text{mA}, I_C=1\text{mA}$
	Response time	Rise time	t_r	-	6	-	μs
Fall time		t_f	-	8	-	μs	

Note:

1. Excess driving current and / or operating temperature higher than recommended conditions may result in severe light degradation or premature failure.

ABSOLUTE MAXIMUM RATINGS at $T_A=25^\circ\text{C}$

Parameter		Symbol	Rating	Unit
Input	Forward current	I_F	50	mA
	Reverse voltage	V_R	6	V
	Power dissipation	P_D	70	mW
Output	Collector-emitter voltage	V_{CE0}	80	V
	Emitter-collector voltage	V_{ECO}	6	V
	Collector current	I_C	50	mA
	Collector power dissipation	P_C	150	mW
Total power dissipation		P_{tot}	170	mW
Isolation voltage ^[1]		V_{iso}	3750	V _{rms}
Operating temperature		T_{opr}	-30~+100	$^\circ\text{C}$
Storage temperature		T_{stg}	-40~+125	$^\circ\text{C}$

Notes:
 1. 40 to 60% RH, AC for 1 minute.
 2. Relative humidity levels maintained between 40% and 60% in production area are recommended to avoid the build-up of static electricity – Ref JEDEC/JESD625-A and JEDEC/J-STD-033.

TECHNICAL DATA

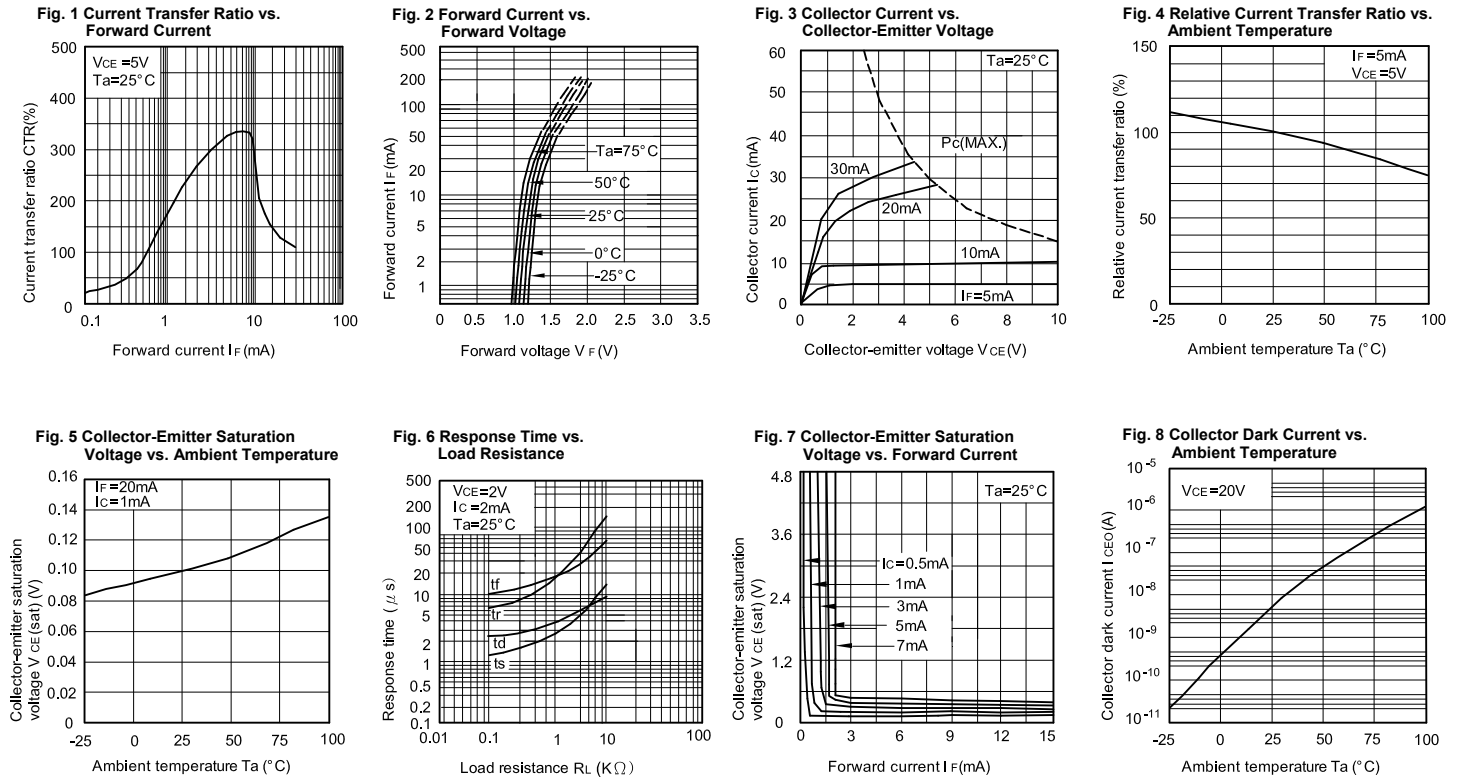

Test Circuit for Response Time

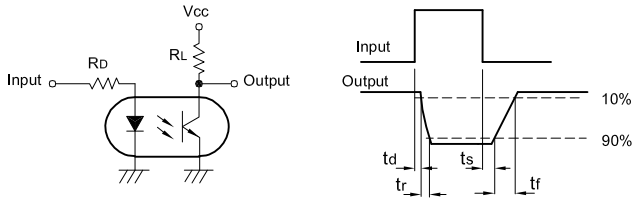

REFLOW SOLDERING PROFILE for LEAD-FREE SMD PROCESS

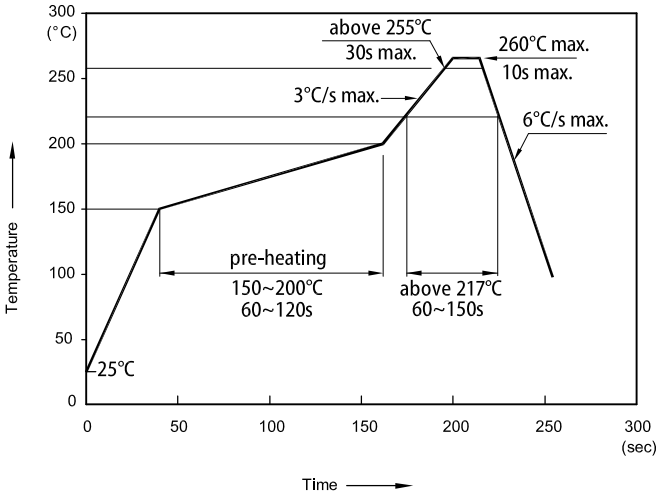

- Notes:
1. Don't cause stress to the LEDs while it is exposed to high temperature.
 2. The maximum number of reflow soldering passes is 2 times.
 3. Reflow soldering is recommended. Other soldering methods are not recommended as they might cause damage to the product.

TAPE SPECIFICATIONS (units : mm)

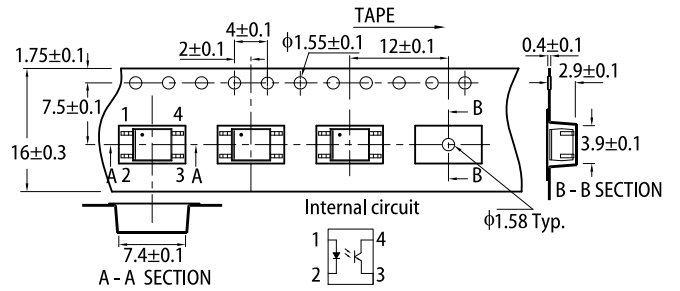

REEL DIMENSION (units : mm)

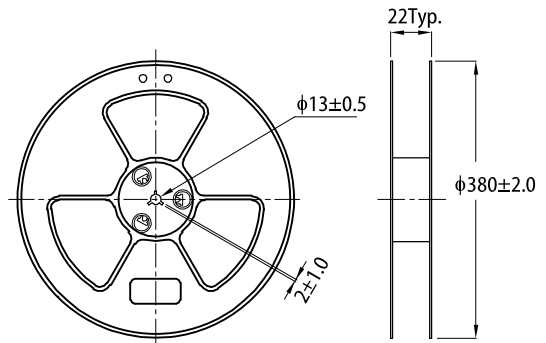

PACKING & LABEL SPECIFICATIONS

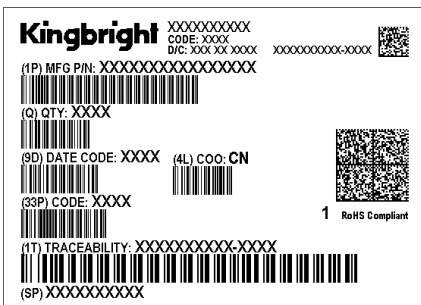
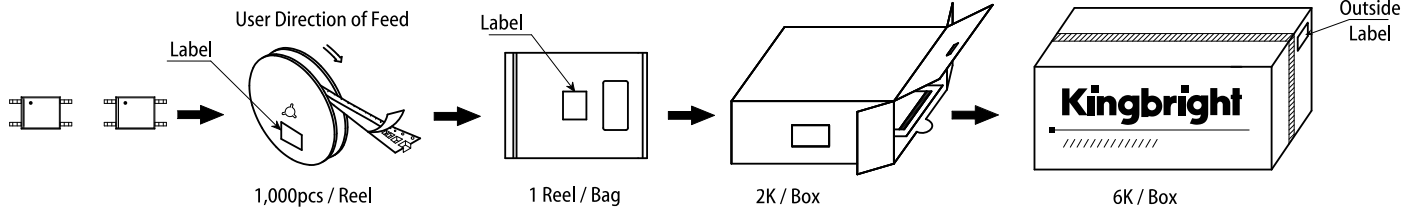

RESTRICTIONS ON PRODUCT USE

1. The information in this document represents typical usage and is provided for technical reference.
2. The information in this document is subject to change without notice. Please refer to the latest version of this document for the most updated information.
3. Please ensure this product is used in accordance with the electrical and environmental specifications and tolerances listed in this document. If the usage exceeds the specification range, Kingbright will not be responsible for any subsequent issues.
4. Semiconductor components may be damaged by electrical or physical stresses. The buyer of Kingbright products is responsible to use them in accordance with all safety regulations. During development and design, the user should insure Kingbright products are used within the latest specification tolerances, and avoid any situations when the failure of Kingbright products might cause physical harm, death, or property loss.
5. The information in this document may not be reproduced or retransmitted without Kingbright's permission.