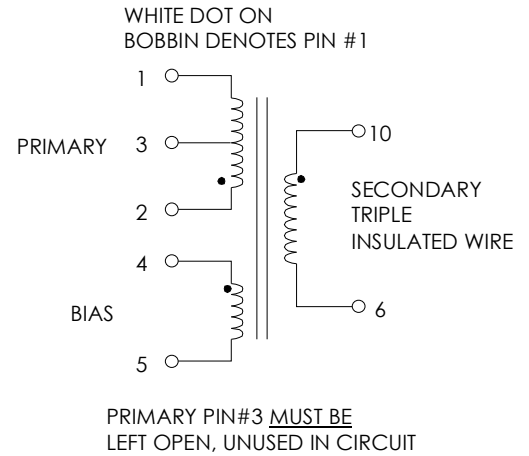

TABLE 1: ELECTRICAL SPECIFICATIONS AT 25°C

SWITCHING TRANSFORMER DESIGNED FOR USE WITH POWER INTEGRATIONS
PWR-TOP204YAI. REFER TO APPLICATION CIRCUIT OF FIGURE 3.

PARAMETER	SPEC LIMITS			UNITS
	MIN.	TYP.	MAX.	
PRIMARY INDUCTANCE (2-1) VOLTAGE = 0.250Vrms FREQUENCY = 100 KHZ	900	950	1000	uH
TURN RATIO'S: SEC (10-6) : PRIMARY (2-1) BIAS (4-5) : PRIMARY (2-1)	-----	1: 3.67 1:13.2	-----	± 3% ± 3%
PRILEAKAGE IND. (SEC SHORTED) VOLTAGE = 0.250Vrms FREQUENCY = 100 KHZ	-----	14.0	18.0	uH
HIPOT: PRIMARY TO SECONDARY BIAS TO SECONDARY	3000 3000	----- -----	----- -----	Vrms Vrms
APP CIRCUIT PARAMETERS: (1) AC LINE VOLTAGE 47/400 Hz OUTPUT VOLTAGE OUTPUT CURRENT CONTINUOUS OUTPUT CURRENT PEAK LINE REGULATION (85 TO 265Vac) LOAD REGULATION 10-100% RIPPLE	85 ----- 0.0 ----- ----- ----- ----- -----	----- 45.0 ----- ----- 0.20 0.20 50.0	265 ----- 1.2 1.5 ----- ----- -----	Vac Vdc Amps Amps ±% ±% ±mV
TRANSFORMER TEMPRISE: 115Vac FULL LOAD	-----	40	-----	°C

FIGURE 1: SCHEMATIC DIAGRAM



NOTE1:

- REINFORCED INSULATION SYSTEM, UL1950, IEC950, CSA-950:**
 A) ALL MATERIALS MEET "UL", "CSA" & "IEC" REQUIREMENTS
 B) TRIPLE BASIC INSULATED SECONDARY.
 C) DESIGNED TO MEET ≥6.2mm CREEPAGE REQUIREMENTS.
 D) VARNISH FINISHED ASSEMBLY.
 E) UL1950 & CSA-950 CERTIFIED: FILE #E162344.
 F) UL CLASS (B) 130 INSULATION SYSTEM PM130-## UL FILE #E177139).

(1) REFER TO APPLICATION CIRCUIT OF FIGURE 3.

FIGURE 2: PHYSICAL DIMENSIONS mm (INCHES)

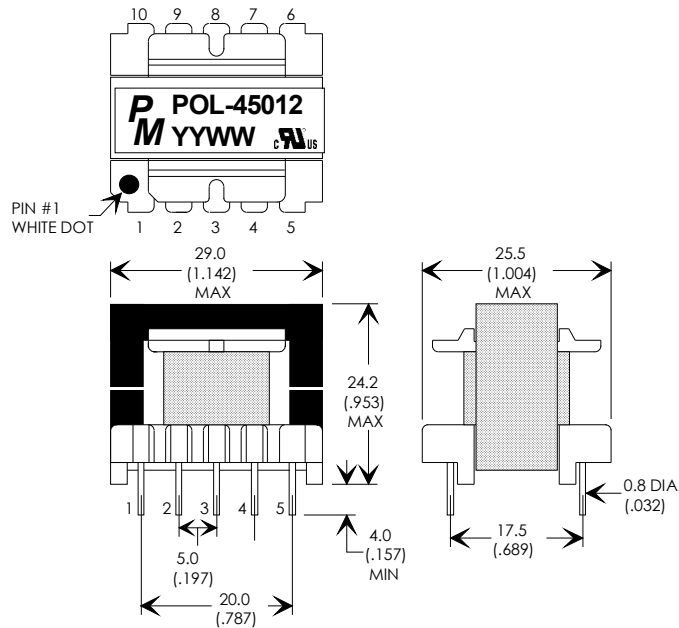

RoHS



UNLESS OTHERWISE SPECIFIED
DIMENSIONS ARE IN MM
DIMENSIONAL TOLERANCES ARE:
DECIMALS ANGLES
X ± .25 ±0° 30'
XX ± .15
DO NOT SCALE DRAWING

TRANSFORMER CONTROL DRAWING

PREMIER P/N: POL-45012	REVISION: 05/07/20
DRAWN BY: TOM O'NEIL	REF: PWR-TOP204YAI
SCALE: NONE	SHEET: 1 OF 2

APPLICATION NOTES

Premier Magnetics' POL-45012 Switch Mode Transformer was designed for use with Power Integrations, Inc. PWR-TOP204YAI three terminal off-line PWM switching regulator in the Flyback Buck-Boost circuit configuration. This conversion topology can provide isolated multiple outputs with efficiencies up to 90%. Premier's POL-45012 transformer has been optimized to provide maximum power throughput.

The PWR-TOPXXX series from Power Integrations, Inc. are self contained 100KHz three terminal voltage controlled PWM switching regulators. This series contains all necessary functions for an off-line switched mode control DC power source. These switching regulators provide a very simple solution to off-line designs. The inductors and transformer used with the PWR-TOPXXX are critical to the performance of the circuit. They define the overall efficiency, output power and overall physical size.

Below is a universal input high precision 54 watt application circuit utilizing Power Integrations PWR-TOP204 switching regulator in the flyback buck-boost configuration. Special care must be taken to properly heat sink U1. The Soft Start capacitor C11 provides sufficient time for the Hot Rail voltage to be stable before switching begins. R2 provides a discharge path for C11 when power is removed. The component values listed are intended for reference purposes only.

FIGURE 3: TYPICAL APPLICATION CIRCUIT

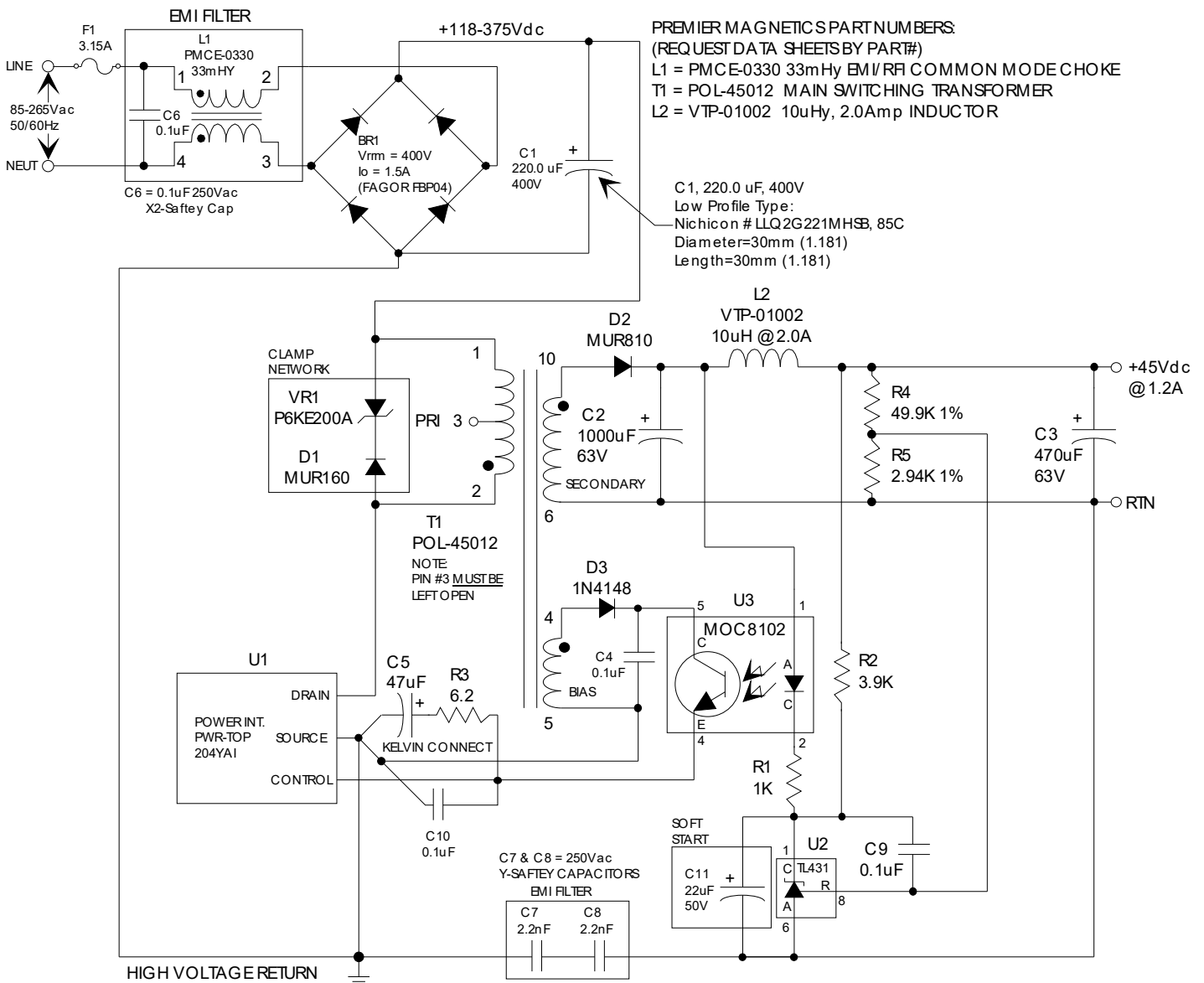

UNLESS OTHERWISE SPECIFIED
 DIMENSIONS ARE IN MM
 DIMENSIONAL TOLERANCES ARE:
 DECIMALS ANGLES
 X ± .25 ±0° 30'
 XX ± .15
 DO NOT SCALE DRAWING

TRANSFORMER CONTROL DRAWING	
PREMIER P/N: POL-45012	REVISION: 05/07/20
DRAWN BY: TOM O'NEIL	REF: PWR-TOP204YAI
SCALE: NONE	SHEET: 2 OF 2