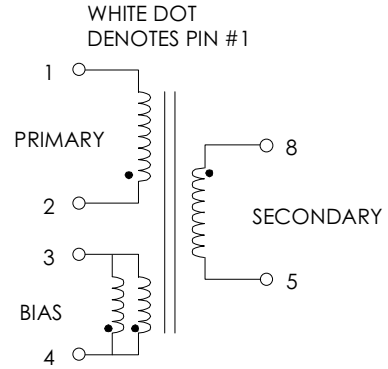

**TABLE 1: ELECTRICAL SPECIFICATIONS AT 25 °C**  
 SWITCHING TRANSFORMER DESIGNED FOR USE WITH POWER INTEGRATIONS  
 PWR-TOP200YAI IC. REFER TO APPLICATION CIRCUIT OF FIGURE 3.

PARAMETER	SPEC LIMITS			UNITS
	MIN.	TYP.	MAX.	
PRIMARY INDUCTANCE (2-1) VOLTAGE = 0.250Vrms FREQUENCY = 100 KHZ	3.78	4.20	4.62	mHY
TURNRATIO'S: SECONDARY (8-5) : PRIMARY (2-1) BIAS (4-3) : PRIMARY (2-1)	—	1:13.00 1:11.81	—	± 3%
PRI LEAKAGE IND. (8-5 SHORTED) VOLTAGE = 0.250Vrms FREQUENCY = 100 KHZ	—	60.0	80.0	μHY
HIPOT: PRIMARY TO SECONDARY BIAS TO SECONDARY	3000 3000	— —	— —	Vrms Vrms
APP CIRCUIT PARAMETERS: (1) AC LINE VOLTAGE 47/400 Hz OUTPUT VOLTAGE OUTPUT CURRENT CONTINUOUS OUTPUT CURRENT PEAK LINE REGULATION (85 TO 265Vac) LOAD REGULATION 10-100% RIPPLE	85 — 100.0 — — — —	— 5.0 — — 2.00 5.00 50.0	265 — 1000 1300 — — —	Vac Vdc mA mA ±% ±% ±mV

**FIGURE 1: SCHEMATIC DIAGRAM**



**NOTE1:**  
**REINFORCED INSULATION SYSTEM, UL1950, IEC950, CSA-950:**  
 A) ALL MATERIALS MEET "UL", "CSA" & "IEC" REQUIREMENTS  
 B) TRIPLE BASIC INSULATED SECONDARY.  
 C) VARNISH FINISHED ASSEMBLY.  
 D) UL1950 & CSA-950 CERTIFIED: FILE #E162344.  
 E) UL CLASS (B) 130 INSULATION SYSTEM PM130-R1,  
 PM130-H1, PM130-H1A (UL FILE #E177139) OR ANY UL  
 AUTHORIZED CLASS (B) INSULATION SYSTEM.

(1) REFER TO APPLICATION CIRCUIT OF FIGURE 3.

**FIGURE 2: PHYSICAL DIMENSIONS mm (INCHES)**

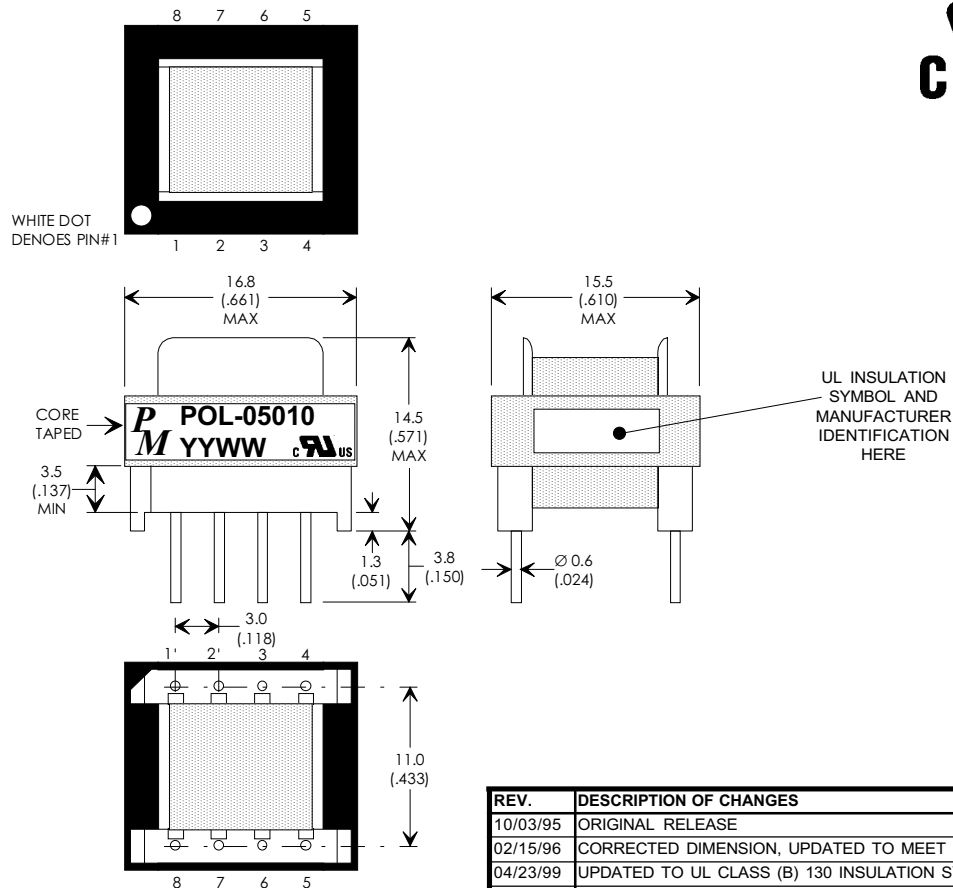

EE16/EI16, 8-PIN HORIZONTAL

REV.	DESCRIPTION OF CHANGES	BY
10/03/95	ORIGINAL RELEASE	TO
02/15/96	CORRECTED DIMENSION, UPDATED TO MEET 5mm PRI/BIAS TO CORE	TO
04/23/99	UPDATED TO UL CLASS (B) 130 INSULATION SYSTEM	MD



**Premier  
Magnetics Inc.**

UNLESS OTHERWISE SPECIFIED  
 DIMENSIONS ARE IN MM  
 DIMENSIONAL TOLERANCES ARE:  
 DECIMALS ANGLES  
 .X ± .25 ±0° 30'  
 .XX ± .15  
 DO NOT SCALE DRAWING

**TRANSFORMER CONTROL DRAWING**

PREMIER P/N: POL-05010	REVISION: 04/23/99
DRAWN BY: TOM O'NEIL	REF: PWR-TOP200YAI
SCALE: NONE	SHEET: 1 OF 6

## APPLICATION NOTES

Premier Magnetics' POL-05010 Switch Mode Transformer was designed for use with Power Integrations, Inc. PWR-TOP200YA1 three terminal off-line PWM switching regulator in the Flyback Buck-Boost circuit configuration. This conversion topology can provide isolated multiple outputs with efficiencies up to 90%. Premier's POL-05010 transformer has been optimized to provide maximum power throughput.

The PWR-TOPXXX series from Power Integrations, Inc. are self contained 100KHz three terminal voltage controlled PWM switching regulators. This series contains all necessary functions for an off-line switched mode control DC power source. These switching regulators provide a very simple solution to off-line designs. The inductors and transformer used with the PWR-TOPXXX are critical to the performance of the circuit. They define the overall efficiency, output power and overall physical size.

Below is a universal input, 5 watt application circuit utilizing Power Integrations PWR-TOP200 switching regulator in the flyback buck-boost configuration. This circuit provides +5Vdc at 1.00Amp continuous and is capable of >1.30Amps peak for short periods of time. This circuit represents the lowest cost implementation and utilizes the bias winding for feedback control. As such the line & load regulation are worse than that which could be achieved by utilizing an opto-coupler to sense the actual outputs. Please consult our application department for assistance on the opto-coupler version. The component values listed are intended for reference purposes only. Resistor R1 may be adjusted up to 100 Ohms MAX. and down to 11 Ohms MIN. As R1 increases in value the output voltages will increase, and vice-versa, thus allowing some fine adjustment on the initial output voltage.

The output clamp resistor R2 is necessary to prevent destructive output runaway under a no-load condition, and has been sized to clamp the output to approximately 10Vdc under a no-load condition.

**FIGURE 3: TYPICAL APPLICATION CIRCUIT**

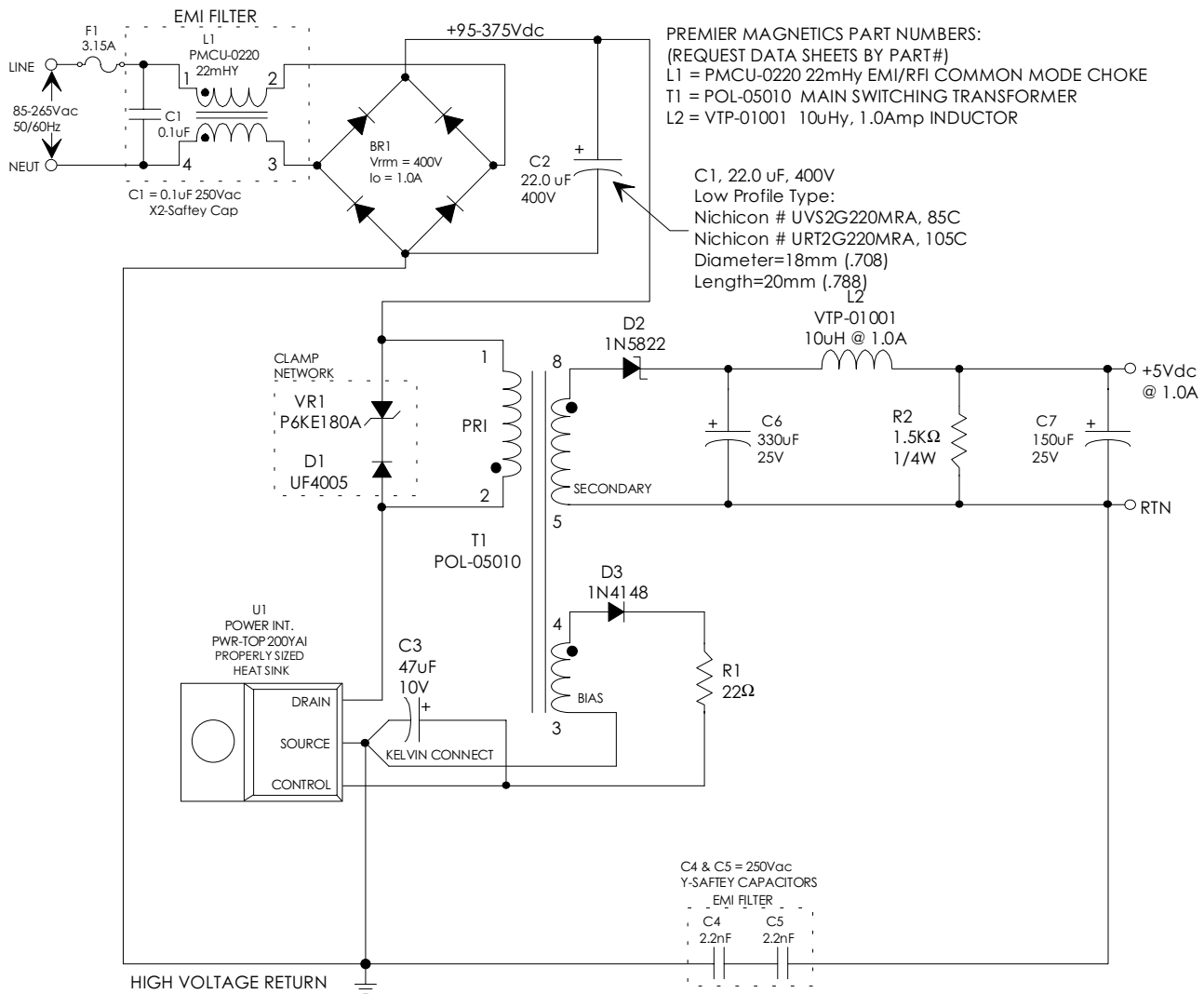

**Premier  
Magnetics Inc.**

UNLESS OTHERWISE SPECIFIED  
DIMENSIONS ARE IN MM  
DIMENSIONAL TOLERANCES ARE:  
DECIMALS ANGLES  
.X ± .25 ±0° 30'  
.XX ± .15  
DO NOT SCALE DRAWING

### TRANSFORMER CONTROL DRAWING

PREMIER P/N: POL-05010	REVISION: 04/23/99
DRAWN BY: TOM O'NEIL	REF: PWR-TOP200YA1
SCALE: NONE	SHEET: 2 OF 6