

PRODUCT NUMBER

SEE PART NO. TABLE

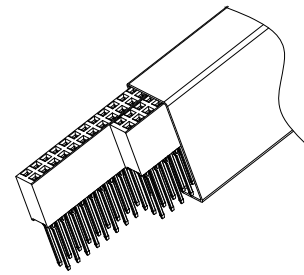
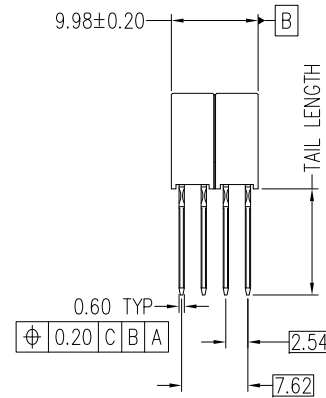
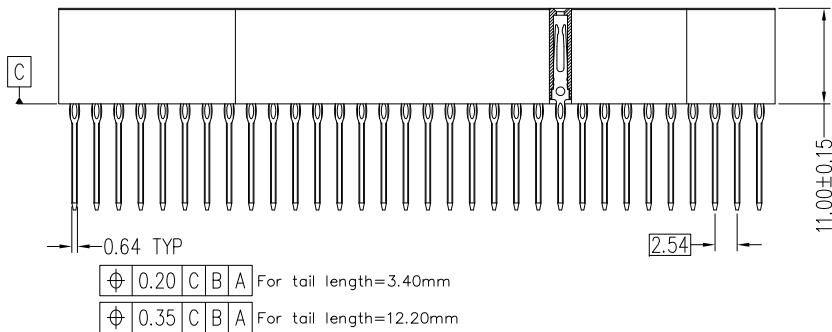
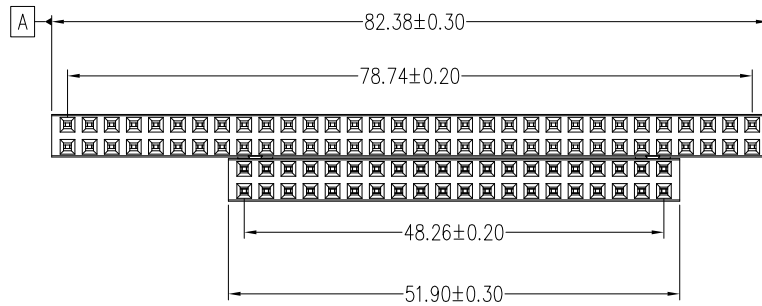

3D View for 52pins
After packing

NOTES:

- MATERIAL:
INSULATION MATERIAL: PPS+30%G.F UL94V-O
CONTACT MATERIAL: PHOSPHER BRONZE
CONTACT PLATING: NICKEL UNDERPLATE,GOLD REFER TO ORDERING CODE
- OPERATION TEMPERATURE: -55°C TO +105°C
- RECOMMEND PROCESS: PRESS FIT
- INSULATION RESISTANCE: 1000MΩ AT 500V/MIN
- WITHSTAND VOLTAGE: 1000V AC/DC
- RATED VOLTAGE: 12V DC, RATED CURRENT: 2AMP
- CONTACT RESISTANCE: 30mΩ MAX
- PRODUCT SPEC: GS-12-1542, PACKING SPEC: GS-14-2678
- ORDERING CODE: 10153302-XX X X X LF

NO. OF PINS
20 = 20 pins
32 = 32 pins
52 = 32+20 pins

LEAD FREE
PACKAGE
1: TUBE

LENGTH OF TAIL
1: 12.20mm
2: 3.40mm

CONTACT FINISH
1: GOLD FLASH OVER NICKEL
2: 10u" GOLD AT MATING AREA+3u" Gold AT TAIL

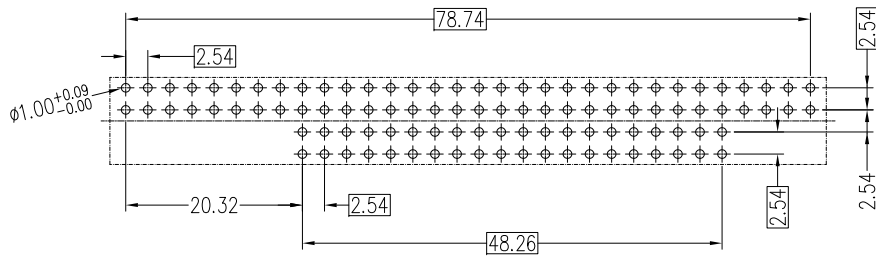

Recommended P.C.B Layout for 52pins (Top Side)
(PCB BOARD TOLERANCE±0.05)

10153302-XX1XXLF	12.20
10153302-XX2XXLF	3.40
PRODUCT NO.	TAIL LENGTH

mat'l. code		surface ISO 1302 ✓		tolerance ISO 406 ISO 1101		projection 1101		product family PC104	
ltr	ecn no	dr	date	tolerances unless otherwise specified		mm		title 2.54pitch PC104 2*20P+2*32P Vertical PF	
A	New Release	JASON	2019-07-15	angles	.X±.40	mm		dwg no	
B	ELX-N-44959	MKX	2022-06-06	linear	.XX±.25	mm		sheet 1 of 2	
				3±x'	.XXX±.15	scale 1:1		size	
				dr	Jason Wang	2019-06-14		10153302	
				engr	Jason Wang	2019-07-15		A3	
				chr	-	-		type	
				appd	TIM YAO	2019-07-15		Product Customer Drawing	
sheet index	revision sheet	B	B						
		1	2						

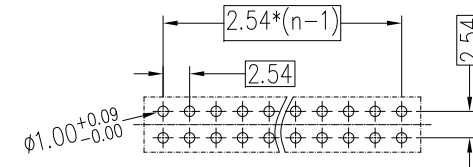
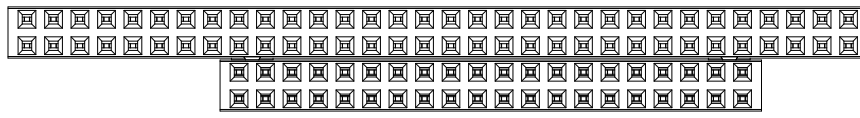
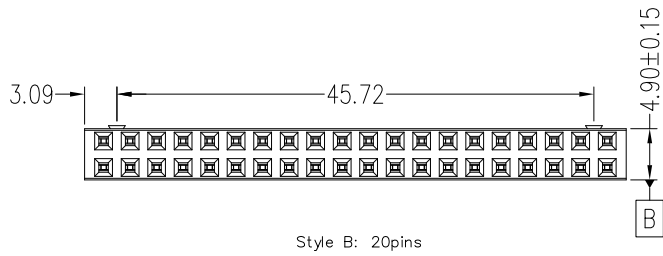
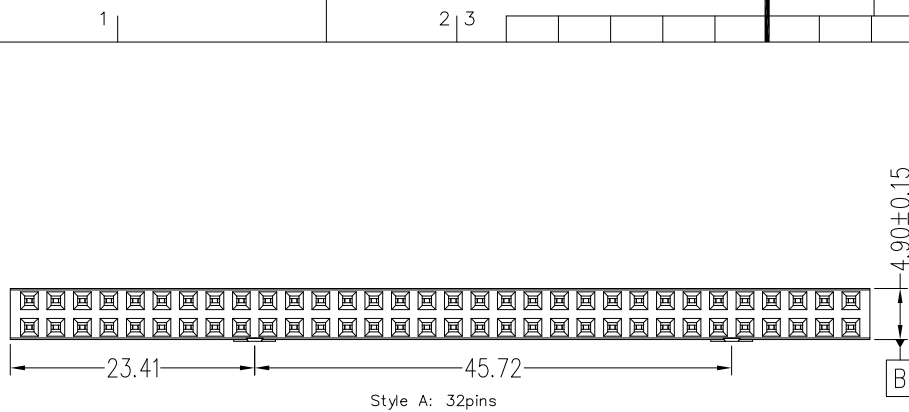

Recommended P.C.B Layout for 32pins & 20pins (Top Side)
(PCB BOARD TOLERANCE±0.05)

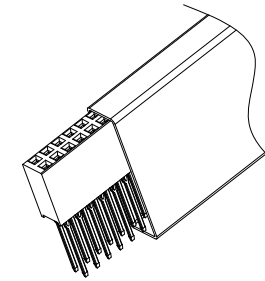

3D View for 32pins & 20pins
After packing

Amphenol
FCI

© 2016 AFCI

mat'l. code		surface		tolerance		projection		product family	
		ISO 1302 ✓		ISO 406 ISO 1101		mm		PC104	
ltr		ecn no		dr		date		title	
B								2.54pitch PC104 2*20P+2*32P Vertical PF	
		angles		linear		mm			
				.X±.40		scale 1:1			
				.XX±.25					
				.XXX±.15					
		dr		Jason Wang		2019-06-14		dwg no	
		engr		Jason Wang		2019-07-15		sheet 2 of 2	
		chr		-		-		size	
		appd		TIM YAO		2019-07-15		A3	
sheet index		revision sheet						type Product Customer Drawing	