

Speaker Boxes
with one CR1511L030UN8-2 inside

BOX1-18082-7SP

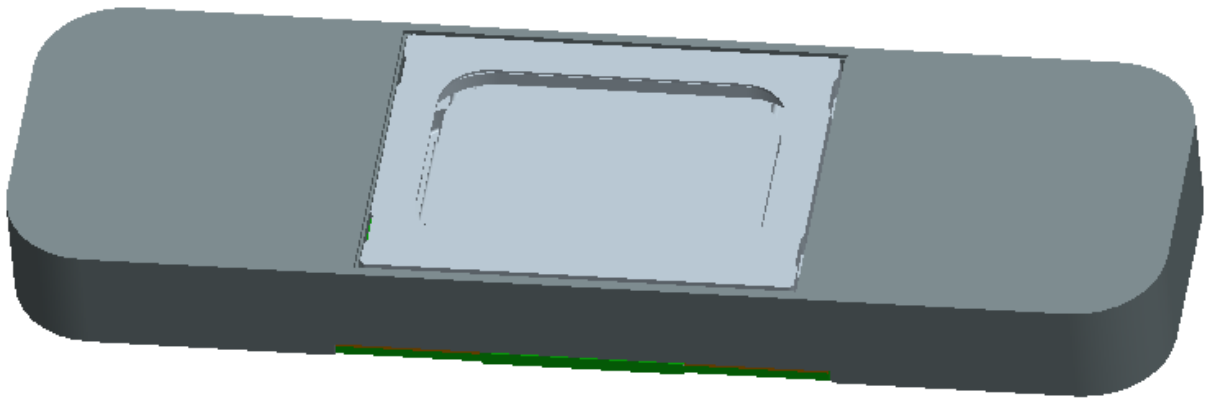

Revision

Date	Version	Status	Changes	Approver
2018/09/05	V0.1	Draft	First release	Jay

1. Mechanical Characteristics

1.1. Mechanical Drawing (Unit: mm)

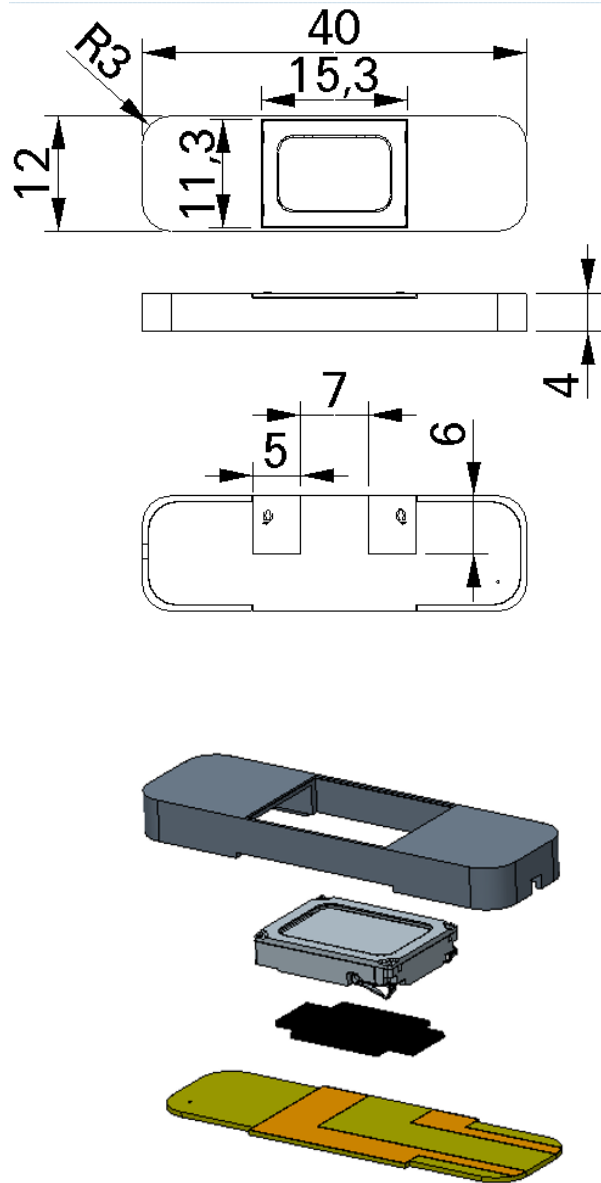

1.2. Material List

1. COVER	ABS
2. BOTTOM	PCB
3. Adhesive	TESA 4972
4. Pad	rubber 60A, 3M467

2. Electro-acoustic characteristics

2.1. Frequency Response & THD

Typical frequency response measured in free field according to chapter 2.4
(d=3.16cm, P=0.8W)

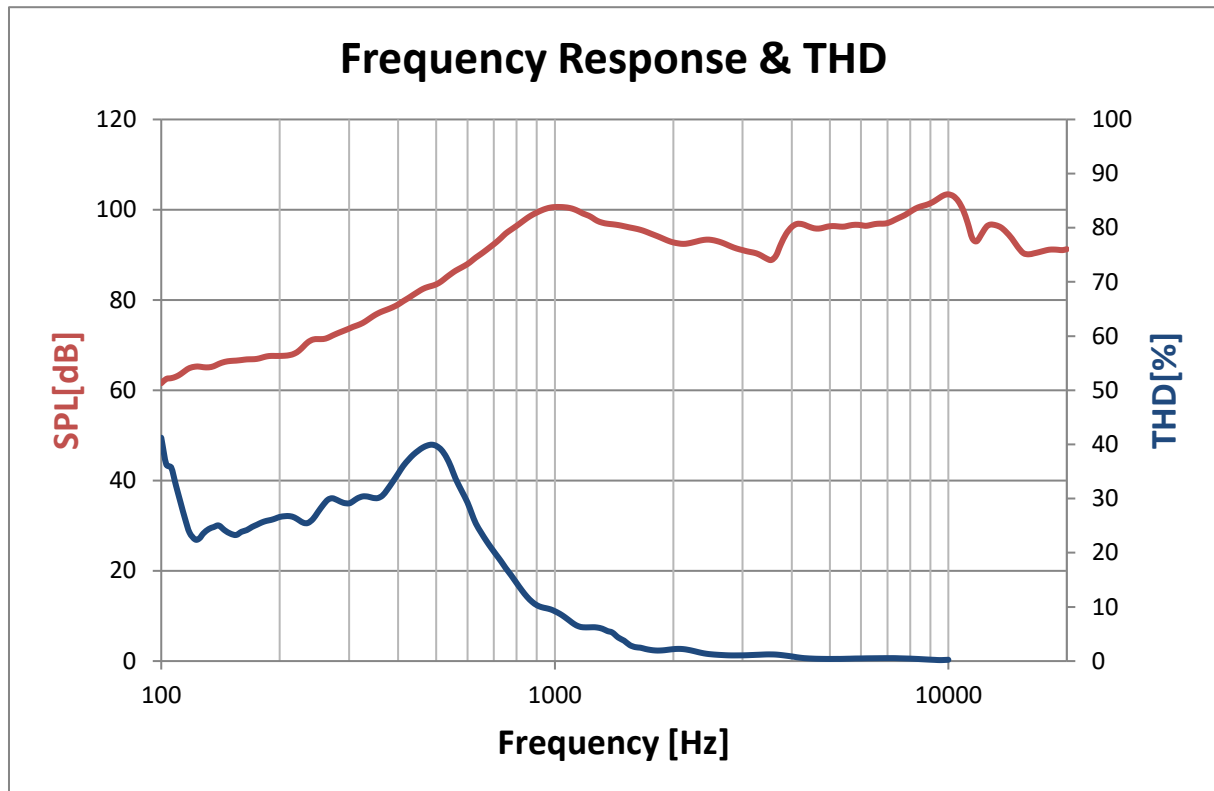

2.2. Electro-Acoustic Parameters

Speaker box measured in free field according to chapter 2.4 per channel.

- | | | |
|---|------------------|-----------------------|
| 1. Rated impedance | Z: | 8Ω |
| 2. Resonance frequency | f ₀ : | 1000Hz ± 15% |
| 3. Measured characteristic sensitivity (3.16cm, 0.8W, 2kHz) | | 100±3dB |
| 4. THD | | according chapter 2.1 |
| 5. Rub & buzz | | no audible noise |

All acoustic measurements at 23 ± 2°C

2.3. Power handling per channel

Input Voltage:	2.38Vrms in 1cc back cavity
Input Source:	Simulated program signal (IEC 268-5) with a peak to RMS ratio of 1.8 to 2.2 in rated frequency range.
Duration:	96 hours

2.4. Measurement setup (Acoustics) per channel

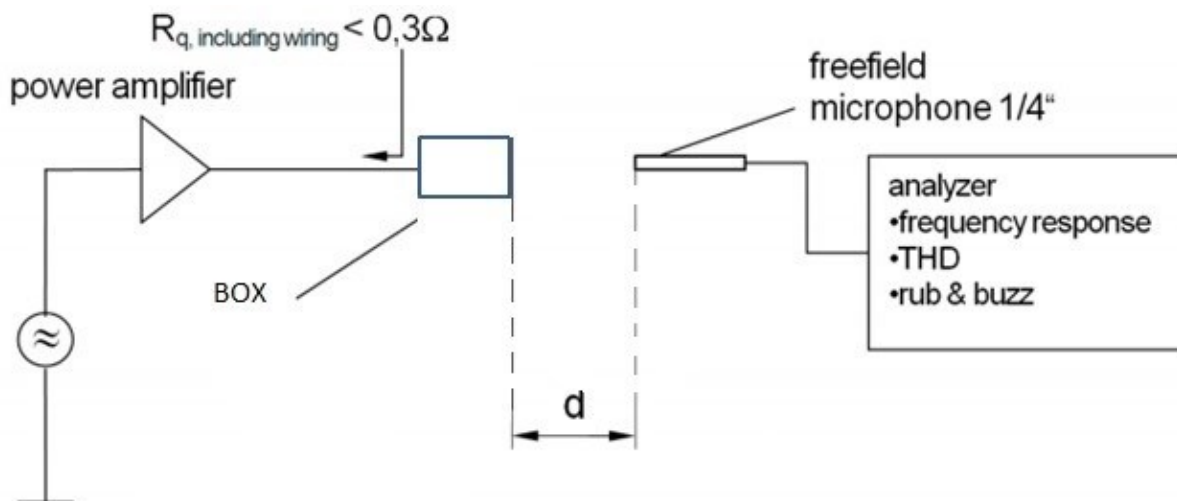

2.5. Measured Parameters per channel

Sensitivity

SPL is expressed in dB ref 20 μ Pa, computed according to IEC 268-5.

Measurement setup according to chapter 2.4.

This test is performed 100% of products in production line.

Frequency response

Frequency response is measured according to measurement setup in chapter 2.4 and checked against the tolerance window defined in chapter 2.1. This test is performed 100% of products in production line.

Total Harmonic Distortion (THD)

THD is measured according to IEC 268-5(2nd to 5th harmonics) and measurement setup in chapter 2.4 and checked against the tolerance window defined in chapter 2.1. This test is performed 100% of products in production line.

2.6. Rub & Buzz

Rub & Buzz will be measured in the Inline-measuring device with a sinusoidal sweep. Rub & Buzz is defined as the maximum level of no harmonic energy, expressed as signal to non-harmonic content ratio, in a certain frequency-range. This test is performed for 100% of products in the production line.