

MOSFET – Power, N-Channel, Ultrafet

100 V, 75 A, 8 mΩ

HUF75652G3

Features

- Ultra Low On-Resistance
 - ◆ $r_{DS(ON)} = 0.008 \Omega$, $V_{GS} = 10 V$
- Simulation Models
 - ◆ Temperature Compensated PSPICE™ and SABER™ Electrical Models
 - ◆ Spice and SABER Thermal Impedance Models
 - ◆ www.onsemi.com
- Peak Current vs Pulse Width Curve
- UIS Rating Curve
- This Device is Pb-Free, Halogen Free/BFR Free and is RoHS Compliant

Packing

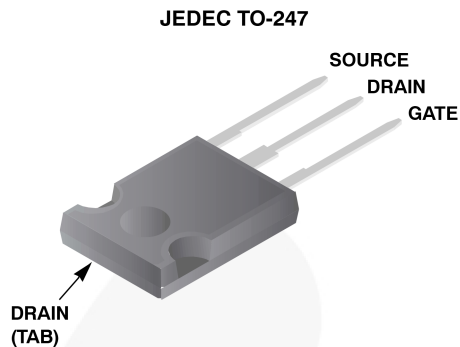
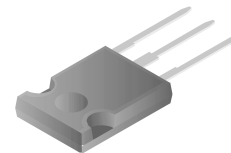
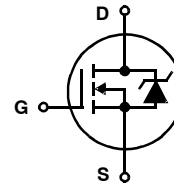

Figure 1.



ON Semiconductor®

www.onsemi.com



TO-247-3LD
CASE 340CK

MARKING DIAGRAMS

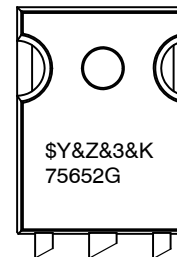

\$Y = ON Semiconductor Logo
 &Z = Assembly Plant Code
 &3 = Data Code (Year & Week)
 &K = Lot
 75652G = Specific Device Code

ORDERING INFORMATION

Part Number	Package	Brand
HUF75652G3	TO-247-3LD	75652G

HUF75652G3

ABSOLUTE MAXIMUM RATINGS $T_C = 25^\circ\text{C}$ unless otherwise specified

Description	Symbol	Ratings	Units
Drain to Source Voltage (Note 1)	V_{DSS}	100	V
Drain to Gate Voltage ($R_{GS} = 20\text{ k}\Omega$) (Note 1)	V_{DGR}	100	V
Gate to Source Voltage	V_{GS}	+20	V
Drain Current – Continuous ($T_C = 25^\circ\text{C}$, $V_{GS} = 10\text{ V}$) (Figure 2) – Continuous ($T_C = 100^\circ\text{C}$, $V_{GS} = 10\text{ V}$) (Figure 2) – Pulsed Drain Current	I_D I_D I_{DM}	75 75 Figure 4	A A
Pulsed Avalanche Rating	UIS	Figures 6	
Power Dissipation – Derate Above 25°C	P_D	515 3.44	W W/ $^\circ\text{C}$
Operating and Storage Temperature	T_J , T_{STG}	-55 to 175	$^\circ\text{C}$
Maximum Temperature for Soldering – Leads at 0.063 in (1.6 mm) from Case for 10 s – Package Body for 10 s, See Techbrief TB334	T_L T_{pkg}	300 260	$^\circ\text{C}$ $^\circ\text{C}$

Stresses exceeding those listed in the Maximum Ratings table may damage the device. If any of these limits are exceeded, device functionality should not be assumed, damage may occur and reliability may be affected.

1. $T_J = 25^\circ\text{C}$ to 150°C .

HUF75652G3

ELECTRICAL SPECIFICATIONS $T_C = 25^\circ\text{C}$ unless otherwise noted

SYMBOL	PARAMETER	TEST CONDITIONS	MIN	TYP	MAX	UNITS
--------	-----------	-----------------	-----	-----	-----	-------

OFF STATE SPECIFICATIONS

BV_{DSS}	Drain to Source Breakdown Voltage	$I_D = 250 \mu\text{A}$, $V_{GS} = 0 \text{ V}$ (Figure 11)	100	-	-	V
I_{DSS}	Zero Gate Voltage Drain Current	$V_{DS} = 95 \text{ V}$, $V_{GS} = 0 \text{ V}$	-	-	1	μA
		$V_{DS} = 90 \text{ V}$, $V_{GS} = 0 \text{ V}$, $T_C = 150^\circ\text{C}$	-	-	250	μA
I_{GSS}	Gate to Source Leakage Current	$V_{GS} = \pm 20 \text{ V}$	-	-	± 100	nA

ON STATE SPECIFICATIONS

$V_{GS(TH)}$	Gate to Source Threshold Voltage	$V_{GS} = V_{DS}$, $I_D = 250 \mu\text{A}$ (Figure 10)	2	-	4	V
$r_{DS(ON)}$	Drain to Source On Resistance	$I_D = 75 \text{ A}$, $V_{GS} = 10 \text{ V}$ (Figure 9)	-	0.0067	0.008	Ω

THERMAL SPECIFICATIONS

$R_{\theta JC}$	Thermal Resistance Junction to Case	TO-247	-	-	0.29	$^\circ\text{C/W}$
$R_{\theta JA}$	Thermal Resistance Junction to Ambient		-	-	30	$^\circ\text{C/W}$

SWITCHING SPECIFICATIONS ($V_{GS} = 10 \text{ V}$)

t_{ON}	Turn-On Time	$V_{DD} = 50 \text{ V}$, $I_D \cong 75 \text{ A}$, $V_{GS} = 10 \text{ V}$, $R_{GS} = 2.0 \Omega$	-	-	320	ns
$t_{d(ON)}$	Turn-On Delay Time		-	18.5	-	ns
t_r	Rise Time		-	195	-	ns
$t_{d(OFF)}$	Turn-Off Delay Time		-	80	-	ns
t_f	Fall Time		-	190	-	ns
t_{OFF}	Turn-Off Time		-	-	410	ns

GATE CHARGE SPECIFICATIONS

$Q_{g(TOT)}$	Total Gate Charge	$V_{GS} = 0 \text{ V}$ to 20 V	$V_{DD} = 50 \text{ V}$, $I_D = 75 \text{ A}$, $I_{g(REF)} = 1.0 \text{ mA}$ (Figures 13)	-	393	475	nC
$Q_{g(10)}$	Gate Charge at 10 V	$V_{GS} = 0 \text{ V}$ to 10 V		-	211	255	nC
$Q_{g(TH)}$	Threshold Gate Charge	$V_{GS} = 0 \text{ V}$ to 2 V		-	14	16.5	nC
Q_{gs}	Gate to Source Gate Charge			-	26	-	nC
Q_{gd}	Gate to Drain "Miller" Charge			-	74	-	nC

CAPACITANCE SPECIFICATIONS

C_{ISS}	Input Capacitance	$V_{DS} = 25 \text{ V}$, $V_{GS} = 0 \text{ V}$, $f = 1 \text{ MHz}$ (Figure 12)	-	7585	-	pF
C_{OSS}	Output Capacitance		-	2345	-	pF
C_{RSS}	Reverse Transfer Capacitance		-	630	-	pF

SOURCE TO DRAIN DIODE SPECIFICATIONS

SYMBOL	PARAMETER	TEST CONDITIONS	MIN	TYP	MAX	UNITS
V_{SD}	Source to Drain Diode Voltage	$I_{SD} = 75 \text{ A}$	-	-	1.25	V
		$I_{SD} = 35 \text{ A}$	-	-	1.00	V
t_{rr}	Reverse Recovery Time	$I_{SD} = 75 \text{ A}$, $dI_{SD}/dt = 100 \text{ A}/\mu\text{s}$	-	-	150	ns
Q_{RR}	Reverse Recovered Charge	$I_{SD} = 75 \text{ A}$, $dI_{SD}/dt = 100 \text{ A}/\mu\text{s}$	-	-	490	nC

HUF75652G3

TYPICAL PERFORMANCE CURVES

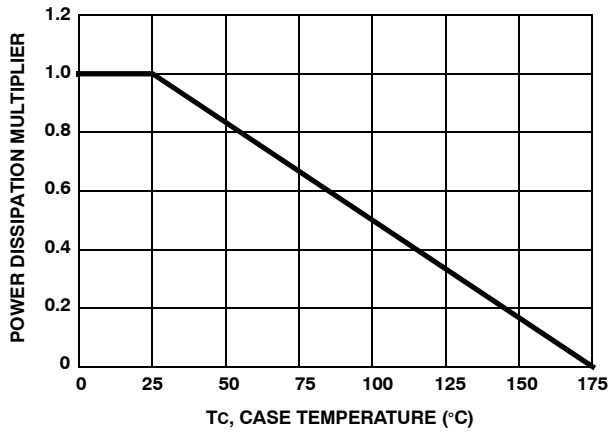

Figure 1. NORMALIZED POWER DISSIPATION vs CASE TEMPERATURE

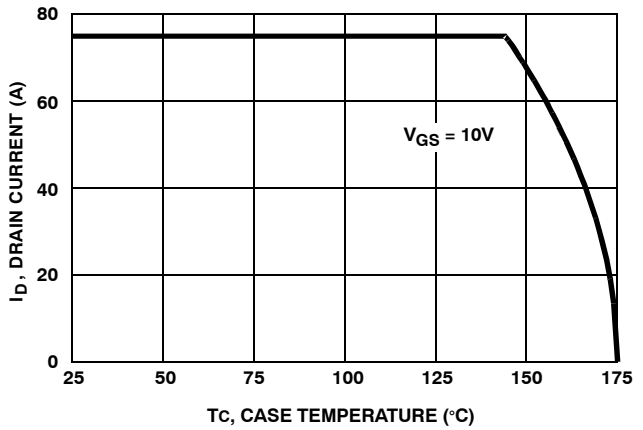

Figure 2. MAXIMUM CONTINUOUS DRAIN CURRENT vs CASE TEMPERATURE

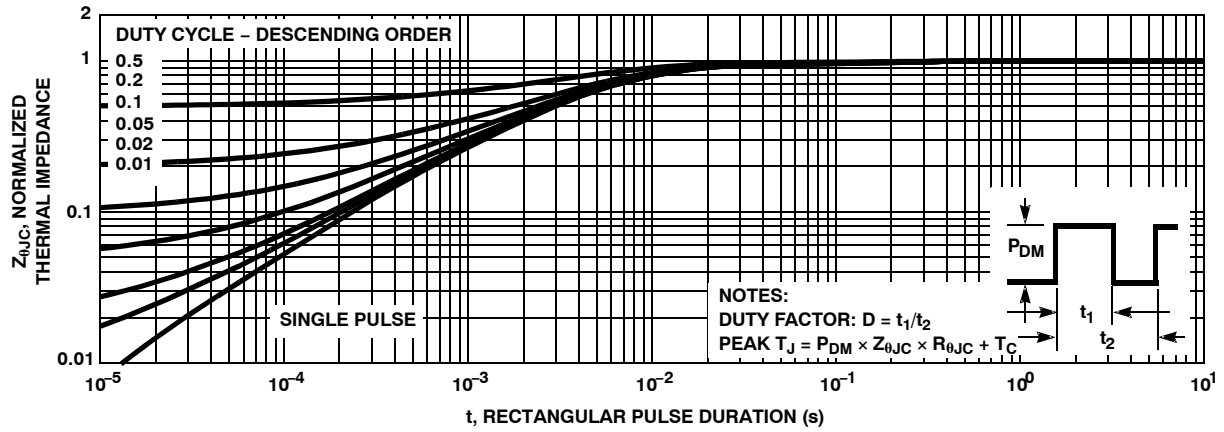

Figure 3. NORMALIZED MAXIMUM TRANSIENT THERMAL IMPEDANCE

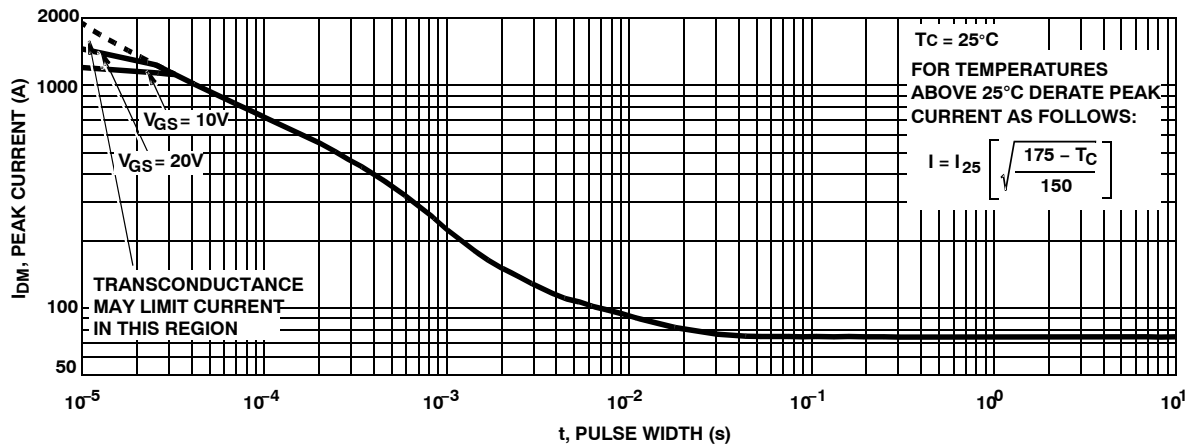

Figure 4. PEAK CURRENT CAPABILITY

TYPICAL PERFORMANCE CURVES (continued)

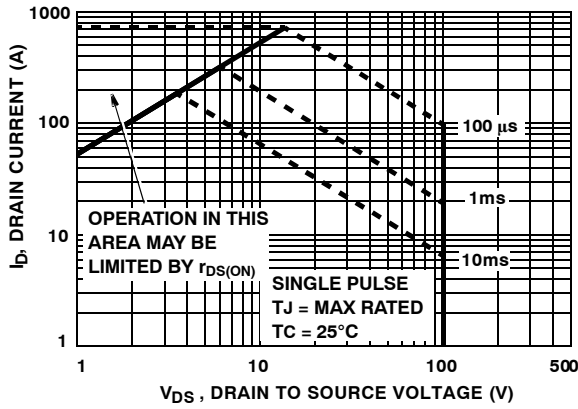

Figure 5. FORWARD BIAS SAFE OPERATING AREA

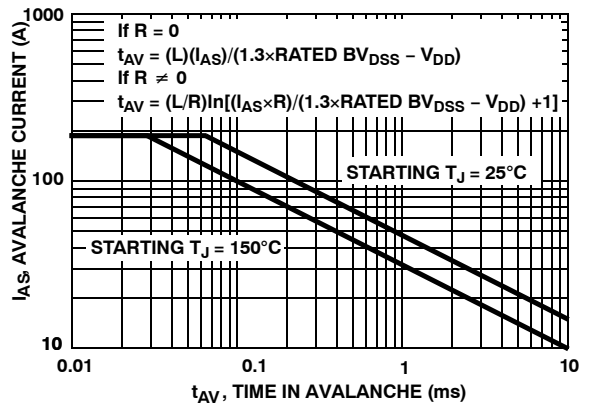

Figure 6. UNCLAMPED INDUCTIVE SWITCHING CAPABILITY

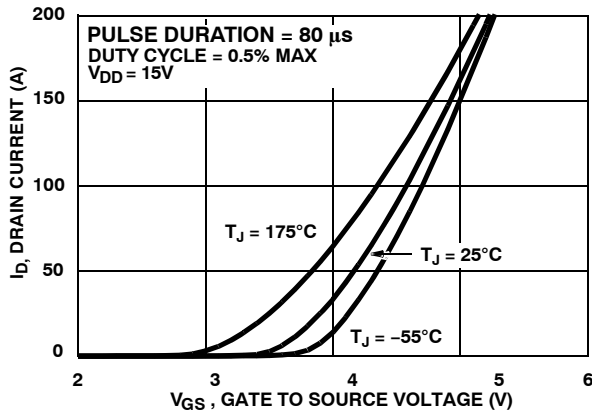

Figure 7. TRANSFER CHARACTERISTICS

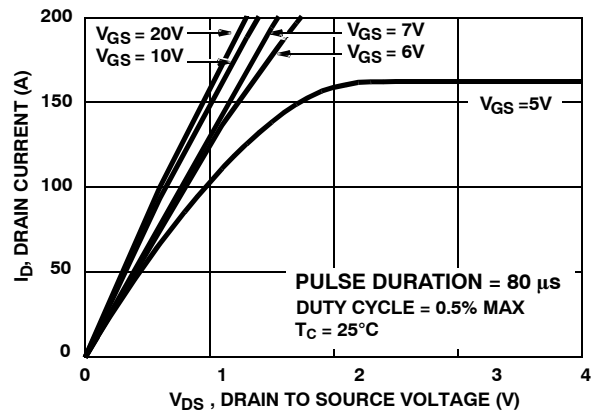

Figure 8. SATURATION CHARACTERISTICS

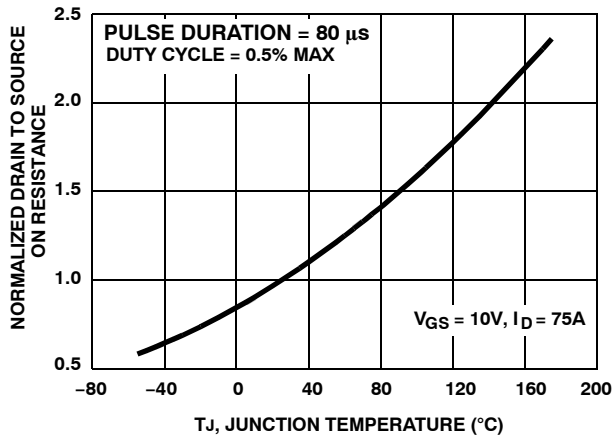

Figure 9. NORMALIZED DRAIN TO SOURCE ON RESISTANCE vs JUNCTION TEMPERATURE

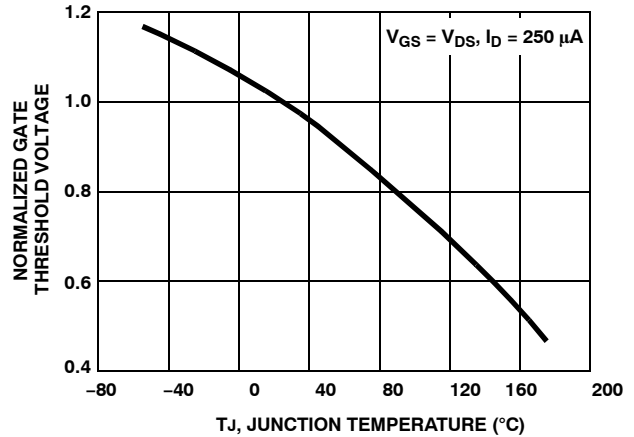

Figure 10. NORMALIZED GATE THRESHOLD VOLTAGE vs JUNCTION TEMPERATURE

HUF75652G3

TYPICAL PERFORMANCE CURVES (continued)

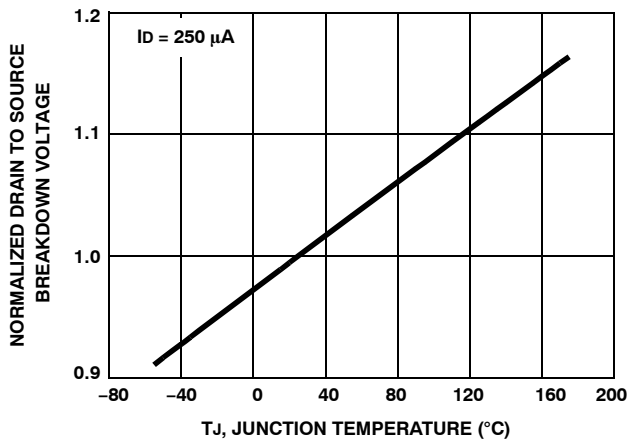

Figure 11. NORMALIZED DRAIN TO SOURCE BREAKDOWN VOLTAGE vs JUNCTION TEMPERATURE

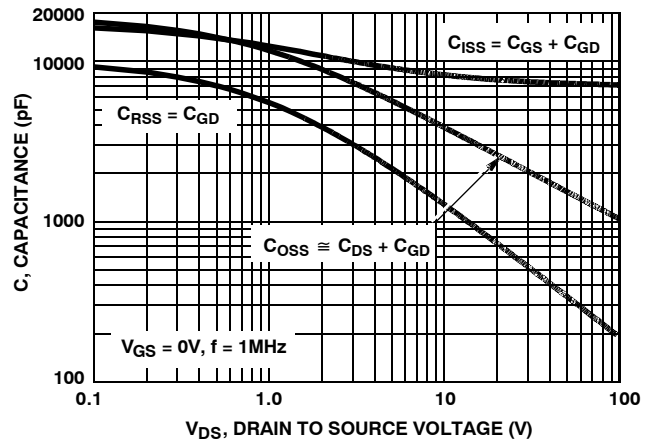

Figure 12. CAPACITANCE vs DRAIN TO SOURCE VOLTAGE

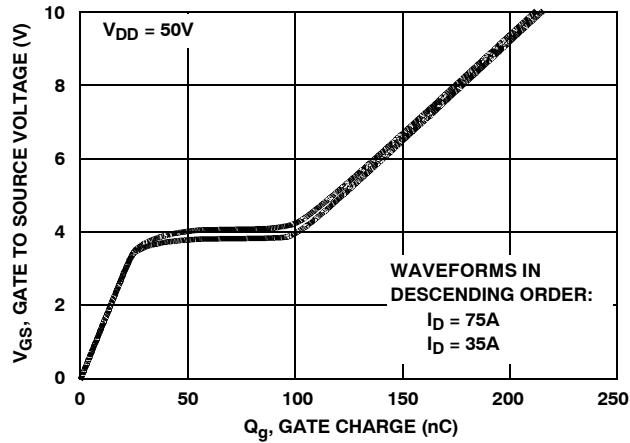

Figure 13. GATE CHARGE WAVEFORMS FOR CONSTANT GATE CURRENT

TEST CIRCUITS AND WAVEFORMS

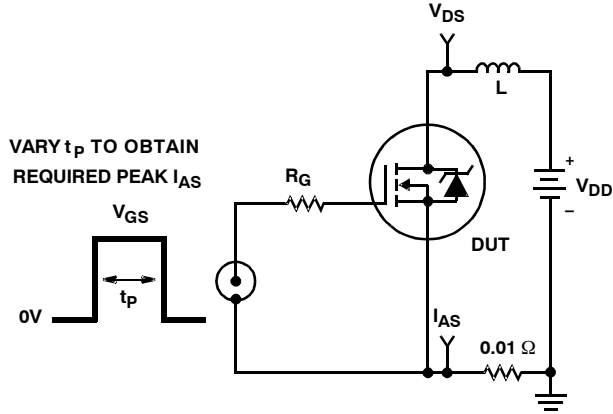

Figure 14. UNCLAMPED ENERGY TEST CIRCUIT

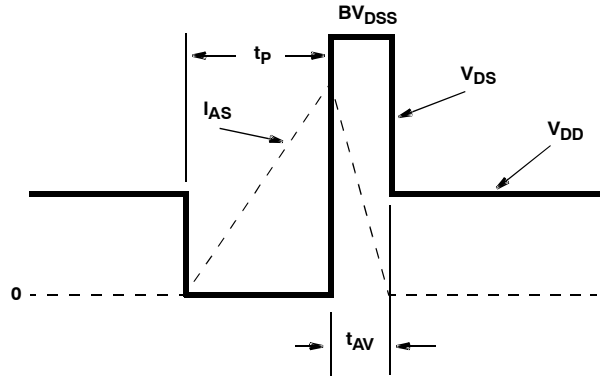

Figure 15. UNCLAMPED ENERGY WAVEFORMS

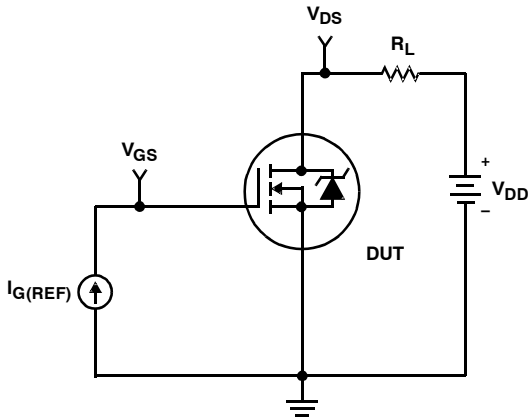

Figure 16. GATE CHARGE TEST CIRCUIT

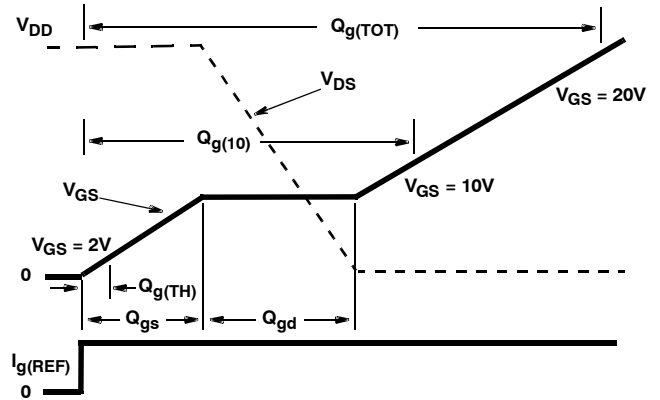

Figure 17. GATE CHARGE WAVEFORM

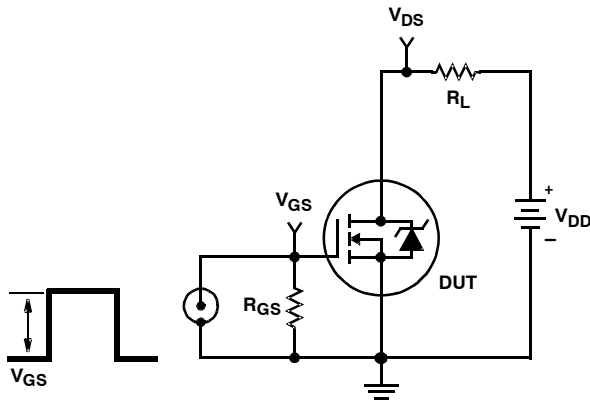

Figure 18. SWITCHING TIME TEST CIRCUIT

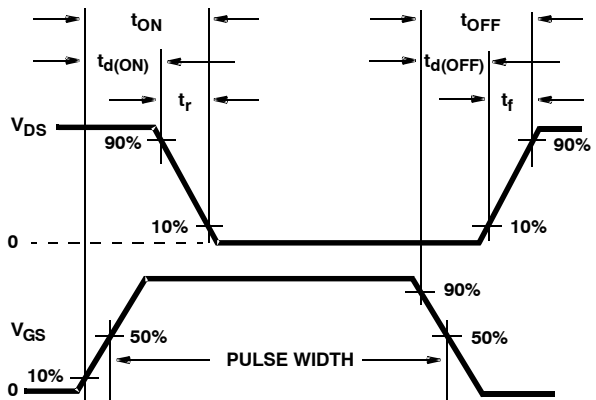

Figure 19. SWITCHING TIME WAVEFORM

SABER Electrical Model

REV 11 May 1999

template ta75652 n2,n1,n3
electrical n2,n1,n3

```
{
var i iscl
d..model dbodymod = (is = 6.55e-12, cjo = 8.71e-9, tt = 7.81e-8, m = 0.50)
d..model dbreakmod = ()
d..model dplcapmod = (cjo = 1.0e-8, is = 1e-30, n=1, m = 0.85)
m..model mmedmod = (type=_n, vto = 2.91, kp = 6.5, is = 1e-30, tox = 1)
m..model mstrongmod = (type=_n, vto = 3.37, kp = 205, is = 1e-30, tox = 1)
m..model mweakmod = (type=_n, vto = 2.56, kp = 0.1, is = 1e-30, tox = 1)
sw_vcsp..model s1amod = (ron = 1e-5, roff = 0.1, von = -5, voff = -3)
sw_vcsp..model s1bmod = (ron = 1e-5, roff = 0.1, von = -3, voff = -5)
sw_vcsp..model s2amod = (ron = 1e-5, roff = 0.1, von = -2, voff = 0)
sw_vcsp..model s2bmod = (ron = 1e-5, roff = 0.1, von = 0, voff = -2)
```

```
c.ca n12 n8 = 11.0e-9
c.cb n15 n14 = 11.4e-9
c.cin n6 n8 = 6.95e-9
```

```
d.body n7 n71 = model=dbodymod
d.break n72 n11 = model=dbreakmod
d.dplcap n10 n5 = model=dplcapmod
```

```
i.it n8 n17 = 1
```

```
l.ldrain n2 n5 = 1e-9
l.gate n1 n9 = 5.74e-9
l.lsource n3 n7 = 4.65e-9
```

```
m.mmed n16 n6 n8 n8 = model=mmedmod, l=1u, w=1u
m.mstrong n16 n6 n8 n8 = model=mstrongmod, l=1u, w=1u
m.mweak n16 n21 n8 n8 = model=mweakmod, l=1u, w=1u
```

```
res.rbreak n17 n18 = 1, tc1 = 1.09e-3, tc2 = 1.04e-7
res.rbody n71 n5 = 1.69e-3, tc1 = 1.95e-3, tc2 = 1.05e-6
res.rdbreak n72 n5 = 1.45e-1, tc1 = 1.02e-4, tc2 = 1.11e-7
res.rdrain n50 n16 = 2.80e-3, tc1 = 1.38e-2, tc2 = 3.75e-5
res.rgate n9 n20 = 0.85
res.rldrain n2 n5 = 10
res.rlgate n1 n9 = 57.4
res.rlsource n3 n7 = 46.5
res.rslc1 n5 n51 = 1e-6, tc1 = 1.05e-4, tc2 = 2.13e-7
res.rslc2 n5 n50 = 1e3
res.rsource n8 n7 = 2.50e-3, tc1 = 0, tc2 = 0
res.rvtemp n18 n19 = 1, tc1 = -3.0e-3, tc2 = 1.21e-6
res.rvthres n22 n8 = 1, tc1 = -2.92e-3, tc2 = -1.48e-5
```

```
spe.ebreak n11 n7 n17 n18 = 117.5
spe.eds n14 n8 n5 n8 = 1
spe.egs n13 n8 n6 n8 = 1
spe.esg n6 n10 n6 n8 = 1
spe.evtemp n20 n6 n18 n22 = 1
spe.evthres n6 n21 n19 n8 = 1
```

```
sw_vcsp.s1a n6 n12 n13 n8 = model=s1amod
sw_vcsp.s1b n13 n12 n13 n8 = model=s1bmod
sw_vcsp.s2a n6 n15 n14 n13 = model=s2amod
sw_vcsp.s2b n13 n15 n14 n13 = model=s2bmod
```

```
v.vbat n22 n19 = dc=1
```

```
equations {
i (n51->n50) +=iscl
iscl: v(n51,n50) = ((v(n5,n51)/(1e-9+abs(v(n5,n51))))*(abs(v(n5,n51))*1e6/455)** 2))
}
}
```

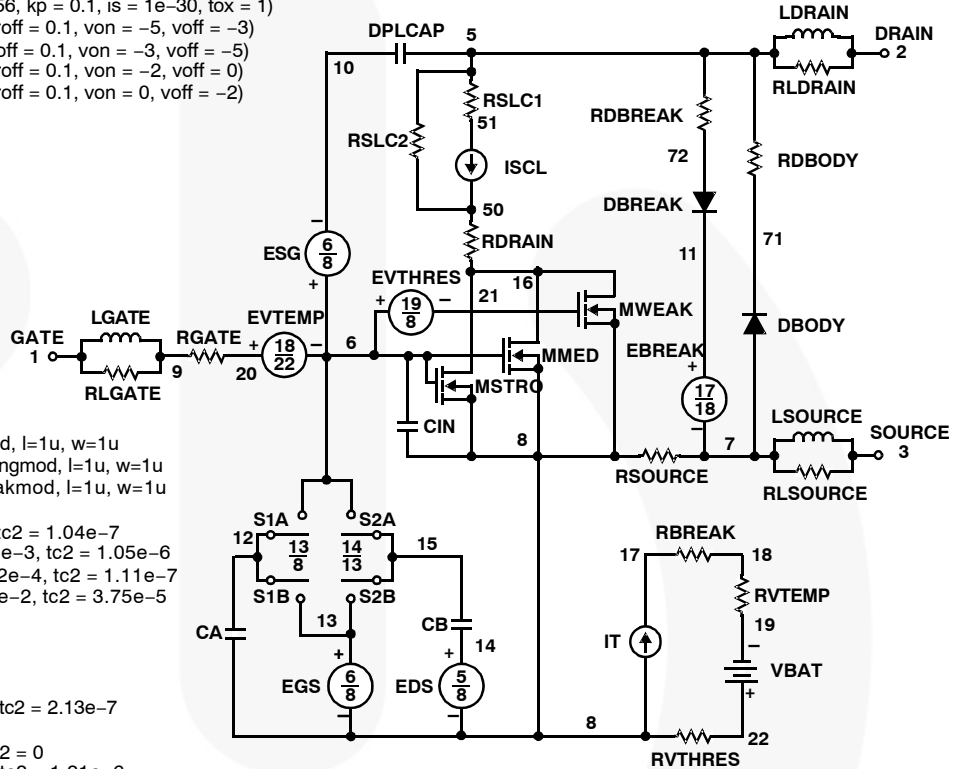

SPICE Thermal Model

REV 1 April 1999

HUF75652T

CTHERM1 th 6 9.75e-3
 CHERM2 6 5 3.90e-2
 CHERM3 5 4 2.50e-2
 CHERM4 4 3 2.95e-2
 CHERM5 3 2 6.55e-2
 CHERM6 2 tl 12.55

R THERM1 th 6 1.96e-3
 R THERM2 6 5 4.89e-3
 R THERM3 5 4 1.38e-2
 R THERM4 4 3 7.73e-2
 R THERM5 3 2 1.17e-1
 R THERM6 2 tl 1.55e-2

SABER Thermal Model

SABER thermal model HUF75652T

```

template thermal_model th tl
thermal_c th, tl
{
    ctherm.ctherm1 th 6 = 9.75e-3
    ctherm.ctherm2 6 5 = 3.90e-2
    ctherm.ctherm3 5 4 = 2.50e-2
    ctherm.ctherm4 4 3 = 2.95e-2
    ctherm.ctherm5 3 2 = 6.55e-2
    ctherm.ctherm6 2 tl = 12.55

    rtherm.rtherm1 th 6 = 1.96e-3
    rtherm.rtherm2 6 5 = 4.89e-3
    rtherm.rtherm3 5 4 = 1.38e-2
    rtherm.rtherm4 4 3 = 7.73e-2
    rtherm.rtherm5 3 2 = 1.17e-1
    rtherm.rtherm6 2 tl = 1.55e-2
}
    
```

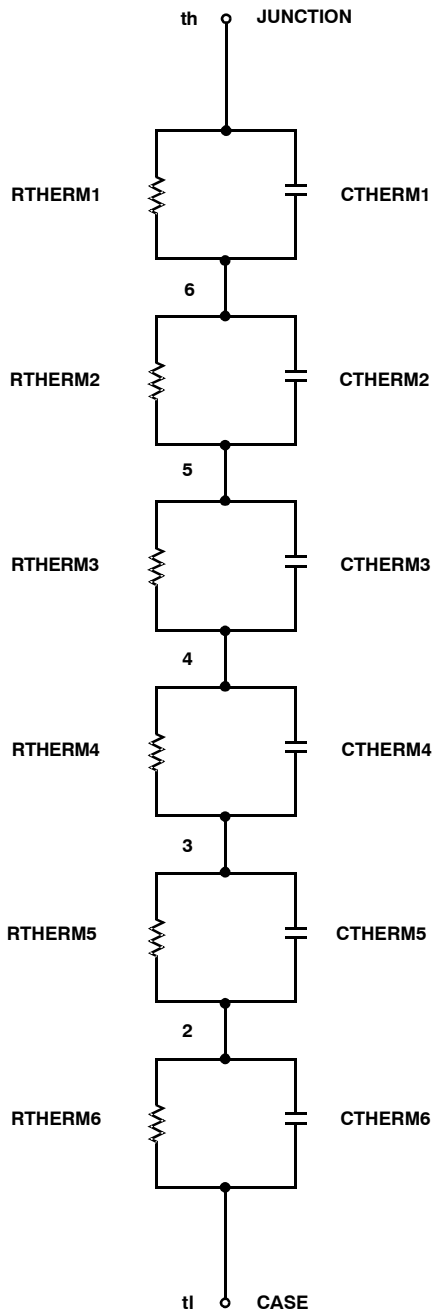

PSPICE is a trademark of MicroSim Corporation.
 Saber is a registered trademark of Sabremark Limited Partnership.

TO-247-3LD SHORT LEAD
CASE 340CK
ISSUE A

DATE 31 JAN 2019

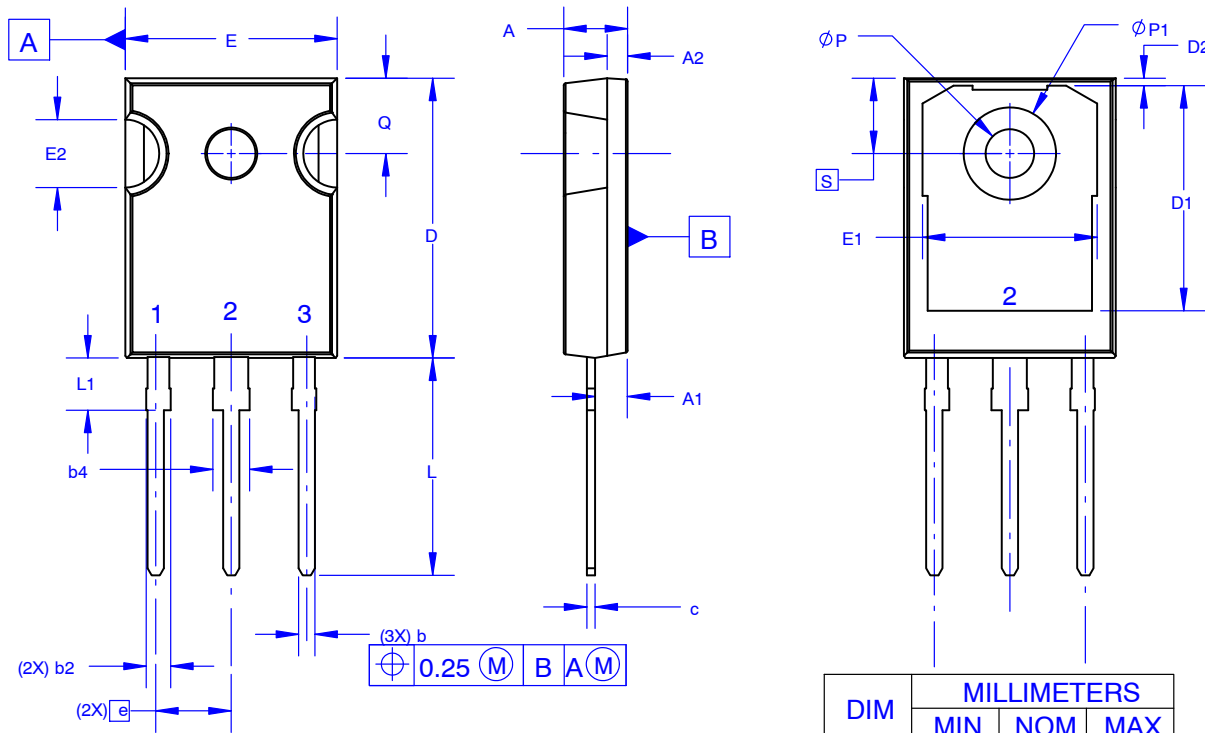

NOTES: UNLESS OTHERWISE SPECIFIED.

- A. DIMENSIONS ARE EXCLUSIVE OF BURRS, MOLD FLASH, AND TIE BAR EXTRUSIONS.
- B. ALL DIMENSIONS ARE IN MILLIMETERS.
- C. DRAWING CONFORMS TO ASME Y14.5 - 2009.
- D. DIMENSION A1 TO BE MEASURED IN THE REGION DEFINED BY L1.
- E. LEAD FINISH IS UNCONTROLLED IN THE REGION DEFINED BY L1.

GENERIC MARKING DIAGRAM*

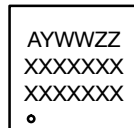

- XXXX = Specific Device Code
- A = Assembly Location
- Y = Year
- WW = Work Week
- ZZ = Assembly Lot Code

*This information is generic. Please refer to device data sheet for actual part marking. Pb-Free indicator, "G" or microdot "•", may or may not be present. Some products may not follow the Generic Marking.

DIM	MILLIMETERS		
	MIN	NOM	MAX
A	4.58	4.70	4.82
A1	2.20	2.40	2.60
A2	1.40	1.50	1.60
b	1.17	1.26	1.35
b2	1.53	1.65	1.77
b4	2.42	2.54	2.66
c	0.51	0.61	0.71
D	20.32	20.57	20.82
D1	13.08	~	~
D2	0.51	0.93	1.35
E	15.37	15.62	15.87
E1	12.81	~	~
E2	4.96	5.08	5.20
e	~	5.56	~
L	15.75	16.00	16.25
L1	3.69	3.81	3.93
ØP	3.51	3.58	3.65
ØP1	6.60	6.80	7.00
Q	5.34	5.46	5.58
S	5.34	5.46	5.58

DOCUMENT NUMBER:	98AON13851G	Electronic versions are uncontrolled except when accessed directly from the Document Repository. Printed versions are uncontrolled except when stamped "CONTROLLED COPY" in red.
DESCRIPTION:	TO-247-3LD SHORT LEAD	PAGE 1 OF 1

ON Semiconductor and are trademarks of Semiconductor Components Industries, LLC dba ON Semiconductor or its subsidiaries in the United States and/or other countries. ON Semiconductor reserves the right to make changes without further notice to any products herein. ON Semiconductor makes no warranty, representation or guarantee regarding the suitability of its products for any particular purpose, nor does ON Semiconductor assume any liability arising out of the application or use of any product or circuit, and specifically disclaims any and all liability, including without limitation special, consequential or incidental damages. ON Semiconductor does not convey any license under its patent rights nor the rights of others.

onsemi, **Onsemi**, and other names, marks, and brands are registered and/or common law trademarks of Semiconductor Components Industries, LLC dba "**onsemi**" or its affiliates and/or subsidiaries in the United States and/or other countries. **onsemi** owns the rights to a number of patents, trademarks, copyrights, trade secrets, and other intellectual property. A listing of **onsemi**'s product/patent coverage may be accessed at www.onsemi.com/site/pdf/Patent-Marking.pdf. **onsemi** reserves the right to make changes at any time to any products or information herein, without notice. The information herein is provided "as-is" and **onsemi** makes no warranty, representation or guarantee regarding the accuracy of the information, product features, availability, functionality, or suitability of its products for any particular purpose, nor does **onsemi** assume any liability arising out of the application or use of any product or circuit, and specifically disclaims any and all liability, including without limitation special, consequential or incidental damages. Buyer is responsible for its products and applications using **onsemi** products, including compliance with all laws, regulations and safety requirements or standards, regardless of any support or applications information provided by **onsemi**. "Typical" parameters which may be provided in **onsemi** data sheets and/or specifications can and do vary in different applications and actual performance may vary over time. All operating parameters, including "Typicals" must be validated for each customer application by customer's technical experts. **onsemi** does not convey any license under any of its intellectual property rights nor the rights of others. **onsemi** products are not designed, intended, or authorized for use as a critical component in life support systems or any FDA Class 3 medical devices or medical devices with a same or similar classification in a foreign jurisdiction or any devices intended for implantation in the human body. Should Buyer purchase or use **onsemi** products for any such unintended or unauthorized application, Buyer shall indemnify and hold **onsemi** and its officers, employees, subsidiaries, affiliates, and distributors harmless against all claims, costs, damages, and expenses, and reasonable attorney fees arising out of, directly or indirectly, any claim of personal injury or death associated with such unintended or unauthorized use, even if such claim alleges that **onsemi** was negligent regarding the design or manufacture of the part. **onsemi** is an Equal Opportunity/Affirmative Action Employer. This literature is subject to all applicable copyright laws and is not for resale in any manner.

ADDITIONAL INFORMATION

TECHNICAL PUBLICATIONS:

Technical Library: www.onsemi.com/design/resources/technical-documentation
onsemi Website: www.onsemi.com

ONLINE SUPPORT: www.onsemi.com/support

For additional information, please contact your local Sales Representative at www.onsemi.com/support/sales