

Groundstudio L9110s module

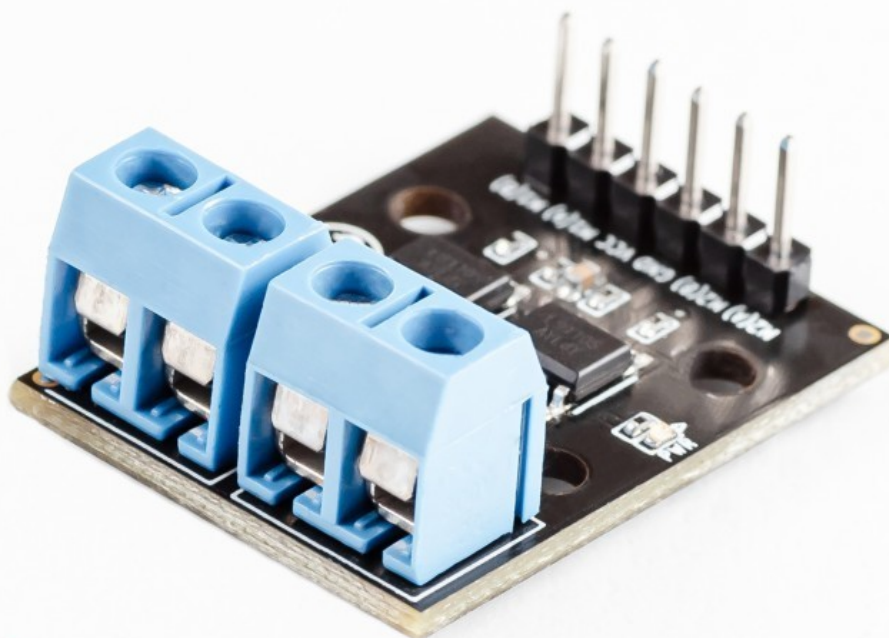

**FABRICAT
ÎN ROMÂNIA**

Table of Contents

Module Circuit Schematic.....	3
Open Source.....	4
License.....	4
Overview.....	4
Technical specifications.....	4
Legal disclaimer notice.....	5
Developer info.....	5
Datasheet Revision History.....	5

Module Circuit Schematic

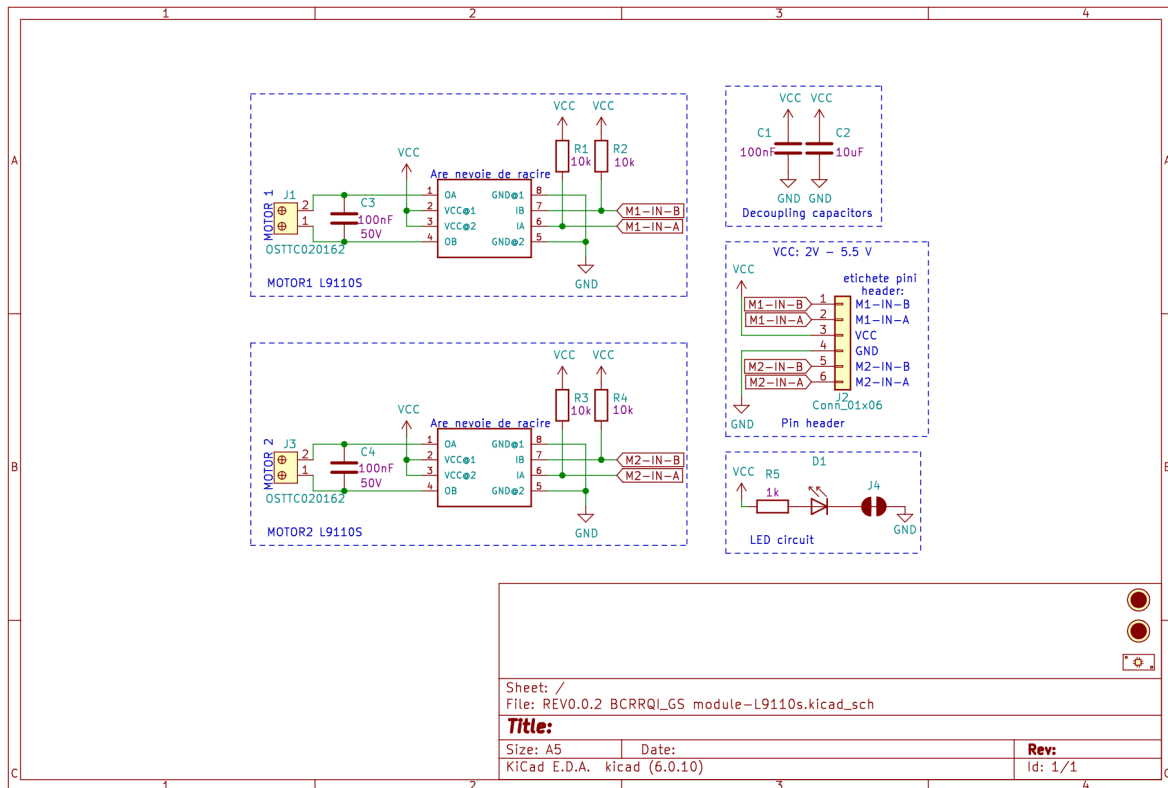

Figure 2: GroundStudio L9110s module schematic circuit [Revision 0.0.1]

Open Source

This is an Open Source project, you can find all the technical documents online:

https://github.com/GroundStudio/GroundStudio_L9110s_module

License

All documentation for GroundStudio Marble Pico is released under the [Attribution-ShareAlike 4.0 International \(CC BY-SA 4.0\)](#) license. You are welcome to use this for commercial purposes.

Please consider contributing back to this project or others to help the open-source hardware community continue to thrive and grow!

Overview

Module based on L9110s double H-bridge with which the speed and direction of two motors can be controlled.

Technical specifications

Supply voltage: **2.5 - 12 V DC**

Current per channel: **800 mA**

Dimensions: **29mm x 23mm**

Legal disclaimer notice

This development board is considered a subassembly in accordance with FCC CFR Title 47 §15.101(e):

[https://www.ecfr.gov/current/title-47/chapter-I/subchapter-A/part-15/subpart-B/section-15.101#p-15.101\(e\)](https://www.ecfr.gov/current/title-47/chapter-I/subchapter-A/part-15/subpart-B/section-15.101#p-15.101(e))

The device does not have a standalone functionality and does not include an enclosure or power supply.

The device is mainly intended for development and prototyping but it can be integrated into a product. In this case it is the responsibility of the developer/manufacturer to obtain all the necessary certifications.

GroundStudio is a registered trademark of ARDUSHOP SRL:

<https://www.tmdn.org/tmview/#/tmview/detail/EM500000018364087>

Developer info

ARDUSHOP SRL

Addr: Str. Aleea Unirii, Nr. 8, Ap. 7, Loc. Selimbar, Jud. Sibiu, ROMANIA, 557260

e-mail: office@ardushop.ro

Datasheet Revision History

[Revision 1] - Initial version release