

REV.	ECR/ECN No.	DESCRIPTION	DRAWN/DATE	CHECKED/DATE	APPROVED/DATE
A		NEW RELEASE	JiangSM 2021-03-02	Staven 2021-03-02	Sam 2021-03-02

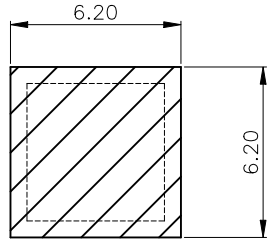
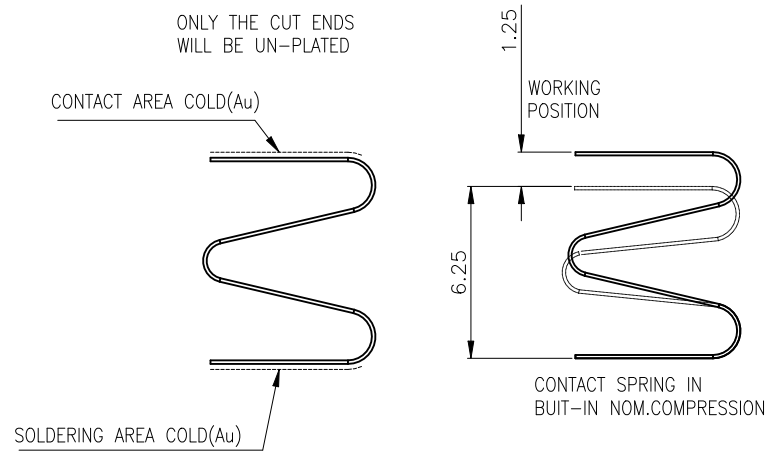

- NOTES:
- 1)MATERIALS: C5210-EH T=0.12mm.
 - 2)FINISH:GOLD FLASH SURFACE PLATING OVER CONTACT AREAS, GOLD FLASH SURFACE PLATING OVER SOLDER AREAS, Ni 40-120u" UNDER PLATING OVER ALL.
 - 3)ALLOWING BURRS 0.03mm Max.
 - 4)OPERATING TEMP: -20 to 125°C.
 - 5)THE SURFACE IS NOT ALLOWED TO HAVE CRUSHING; SCRATCH;DEFORMATION;DIE MARKS;OIL STAINS.
 - 6)""THE SYMBOL INDICATES THE DIMENSION OF KEY FUNCTION INSPECTION.

A

A

B

B

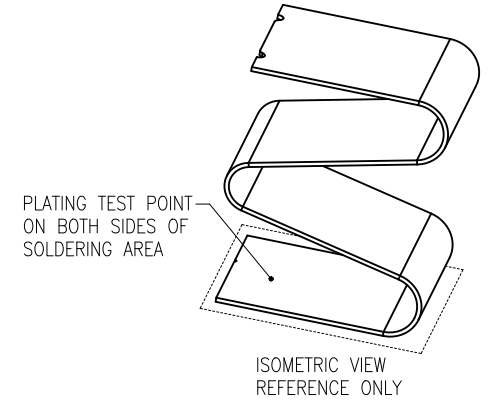
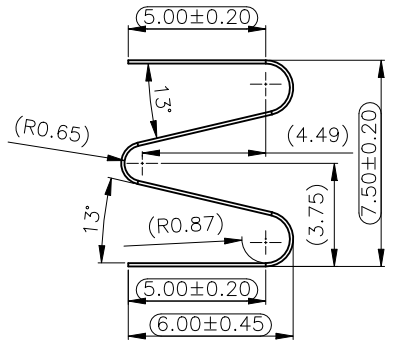
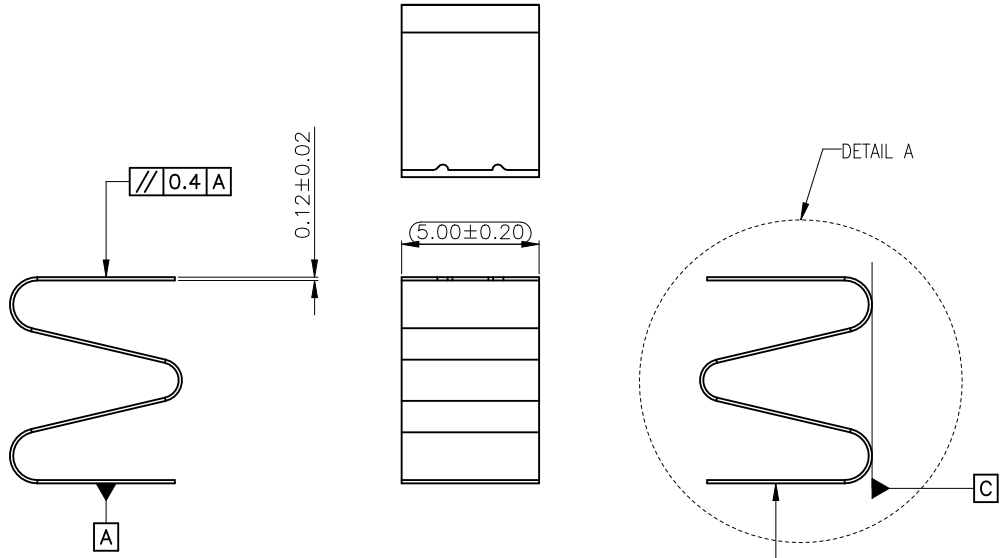

C

C

D

D

HATCH AREA REPRESENTS UN-INTERRUPTED SURFACE FOR SMT NOZZLE

UNLESS OTHERWISE SPECIFIED TOLERANCES				ANGLE OF PROJECTION		Amphenol AORORA	
X.	±0.30	X. °	± 5'			Amphenol Aorora Technology (Huizhou) Co.,Ltd	
X.X	±0.25	X.X °	± 4'				
X.XX	±0.20	X.XX °	± 3'	DOC TYPE: Customer Drw		TITLE: H7.5 SPRING	
X.XXX	±0.15	X.XXX °	± 2'	DRAWN DATE: JiangSM 2021-03-02		SIZE: A4	PART NUMBER: Z02J-4F7L1-11000
LINEAR DIMS		ANGLES DIMS		DESIGN DATE: JiangSM 2021-03-02		REV. A	
DWG NO.: A-S0653				CHECKED DATE: Staven 2021-03-02		SCALE: 1:1	
MATERIAL: SEE NOTES		FINISHED: SEE NOTES		APPROVED DATE: Sam 2021-03-02		UNIT: mm	SHEET 1 OF 1

This document is the property of and embodies CONFIDENTIAL and PROPRIETARY information of AOR. No part of the information shown on this document may be used in any way or disclosed to others without the written consent of AOR. © 2019 AOR



REV.	ECR/ECN No.	DESCRIPTION	DRAWN/DATE	CHECKED/DATE	APPROVED/DATE
A	ECN2021064	FORMAL VERSION RELEASE	JiangSM 2021-06-23	Staven 2021-06-23	Biao 2021-06-23

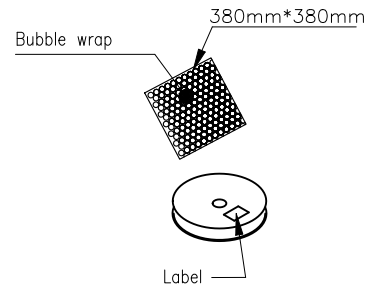
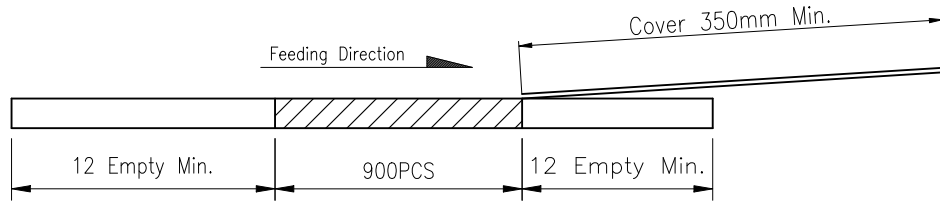
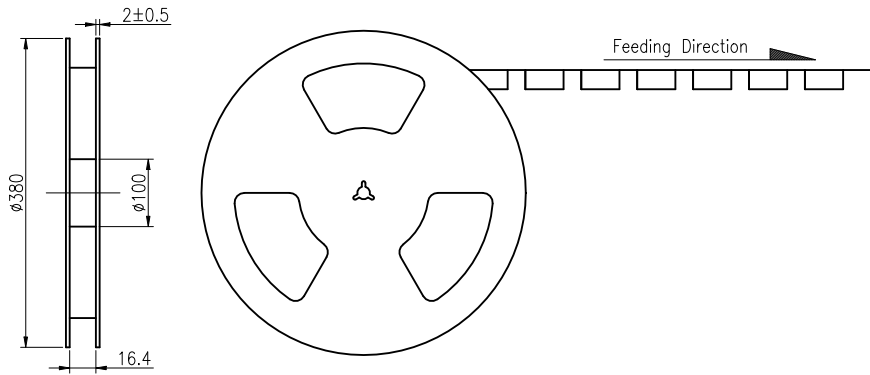
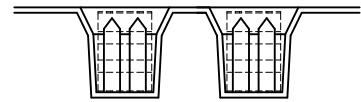
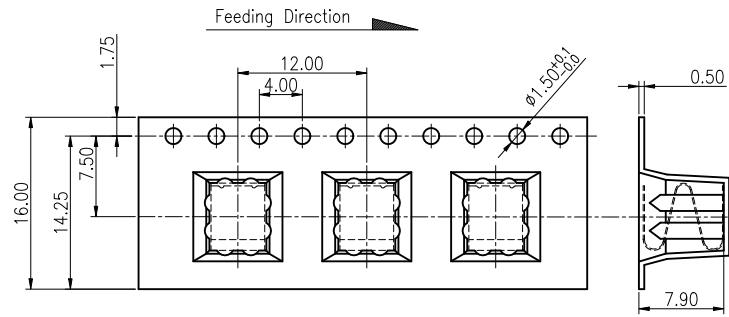

Note:

- Material:
 - 1.1 Tape:PS,T=0.5mm,Transparent
 - 1.2 Reel:HIPS,Blue
 - 1.3 Cover:PET,Transparent
- Reel Package:900PCS/Reel.
- Carton Package: 14 Reels/Carton (12600=14*900/Carton).
- Pull-off Force: 0.2N~1.2N(20~120gf);
 Pull-off Degree: 165°~180° ;
 Pull-off Speed: 300mm/Minute.

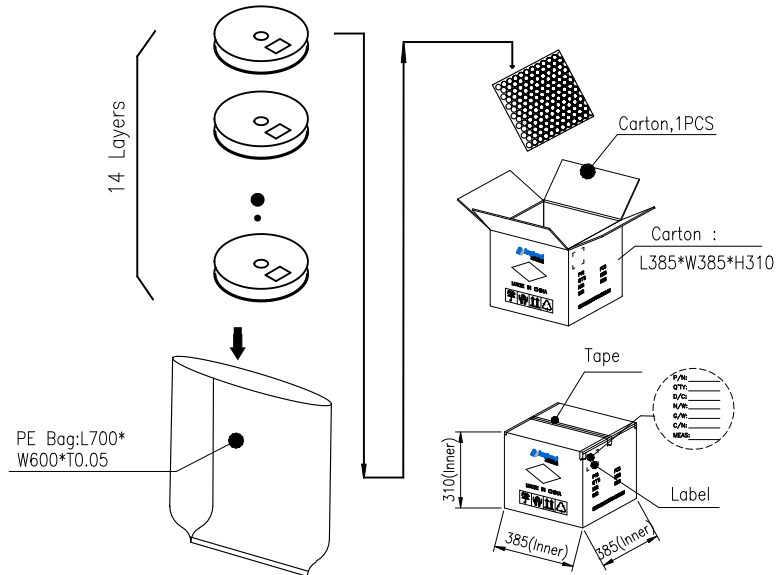

UNLESS OTHERWISE SPECIFIED TOLERANCES				ANGLE OF PROJECTION		Amphenol AORORA	
X.	±0.30	X. °	± 5'			Amphenol Aorora Technology (Huizhou) Co.,Ltd	
X.X	±0.25	X.X °	± 4'				
X.XX	±0.20	X.XX °	± 3'	DOC TYPE		TITLE:	
X.XXX	±0.15	X.XXX °	± 2'	Package Drw		H7.5 SPRING	
LINEAR DIMS		ANGLES DIMS		DRAWN	DATE	JiangSM 2021-06-23	
DWG NO.:		A-H0364		DESIGN	DATE	JiangSM 2021-06-23	
MATERIAL		SEE NOTES		CHECKED	DATE	Staven 2021-06-23	
FINISHED		SEE NOTES		APPROVED	DATE	Biao 2021-06-23	
SIZE	PART NUMBER		REV.	TITLE			
A4	Z02J-4F7L1-11000		A	H7.5 SPRING			
SCALE	1:1	UNIT : mm	SHEET 1 OF 1				