



WS2118E00 User Guide

WS2118-00 Development Kit

Drift 0.2

Prepared By	Reviewed By	Approved By

Index

1. INTRODUCTION.....	2
2. GETTING STARTED.....	3
2.1. SYSTEM REQUIREMENTS.....	3
2.2. APPLICATION SOFTWARE SETUP	3
3. HARDWARE DESCRIPTION	4
3.1. BOARD OVERVIEW.....	4
3.2. WS2118-00 MODULE CONNECTIONS	5
3.3. POWER SUPPLY	6
3.4. OTHER JUMPERS	7
3.5. EXTENSION CONNECTORS.....	7
3.6. PUSH-BUTTONS	8
3.7. JTAG CONNECTOR	8
3.8. LEDs	8
3.9. STM32L151CBU6 MICROCONTROLLER.....	8
3.10. HARDWARE SETUP.....	8
4. SCHEMATIC DIAGRAMS	10
5. HISTORY CHANGE	14

1. INTRODUCTION

The Jorjin WS2118-00 is Bluetooth® Low Energy and Sub-1GHz dual band module. The WS2118E00 is the development kit for WS2118-00. The WS2118E00 provides a set of hardware resources for RF signal evaluation of both BLE and Sub-1GHz and development platform. It also provides a set of hardware resources for a wide range of application scenarios: sensor data (accelerometer, pressure and temperature sensor, needs additional sensor board), remote control (buttons and LEDs) and debug message management through USB virtual COM. Three power options are available (USB only, battery only and external power supply plus USB) for high application development and testing flexibility.

Figure 1: WS2118E00 development kit

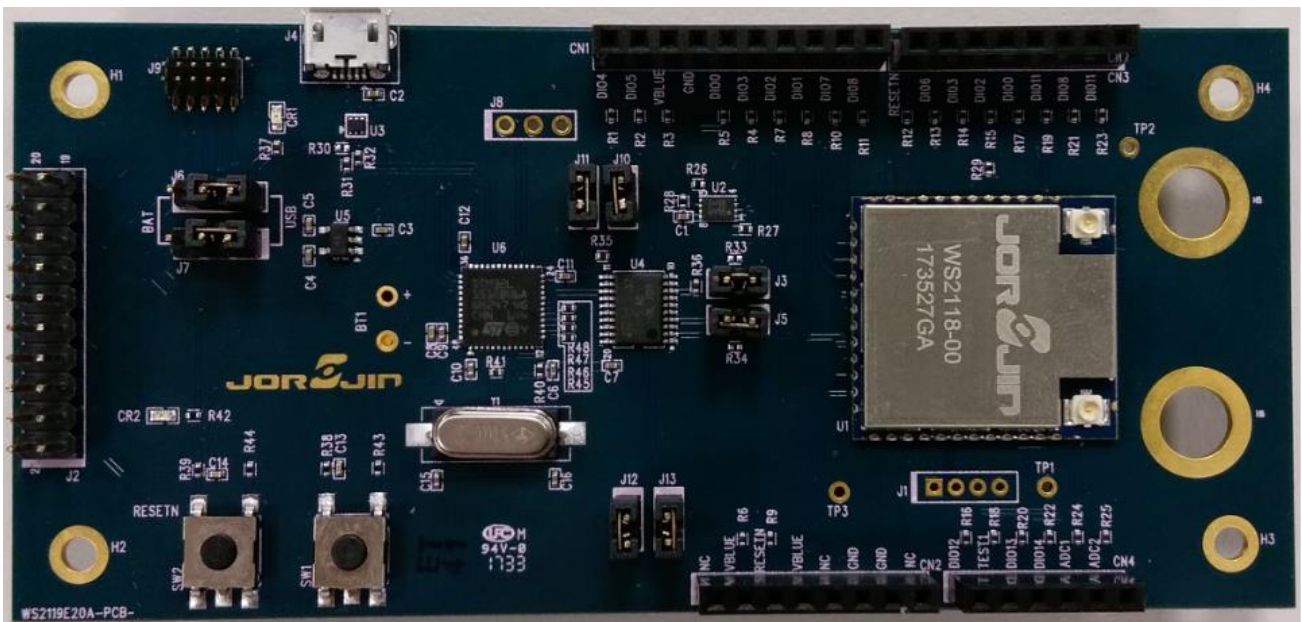

2. GETTING STARTED

2.1. System requirements

The application software require:

- PC with Intel® or AMD® processor running one of the following Microsoft® operating systems:
 - Windows XP SP3
 - Windows Vista
 - Windows 7
 - Windows 10
- At least 128 MB of RAM
- USB ports
- At least 40 MB of available hard disk space
- Adobe Acrobat Reader 6.0 or later.

2.2. Application software setup

Please download the application from below link.

BlueNRG-1 DK SW package:

http://www.st.com/content/st_com/en/products/embedded-software/evaluation-tool-software/stsw-bluenrg1-dk.html

BLUENRG family GUI:

http://www.st.com/content/st_com/en/products/embedded-software/wireless-connectivity-software/stsw-bnrgui.html

And please contact Jorjin to get more application and development software.

3. HARDWARE DESCRIPTION

3.1. Board overview

The following figure and table describe physical sections of the board.

Figure 2: WS2118E00 board components

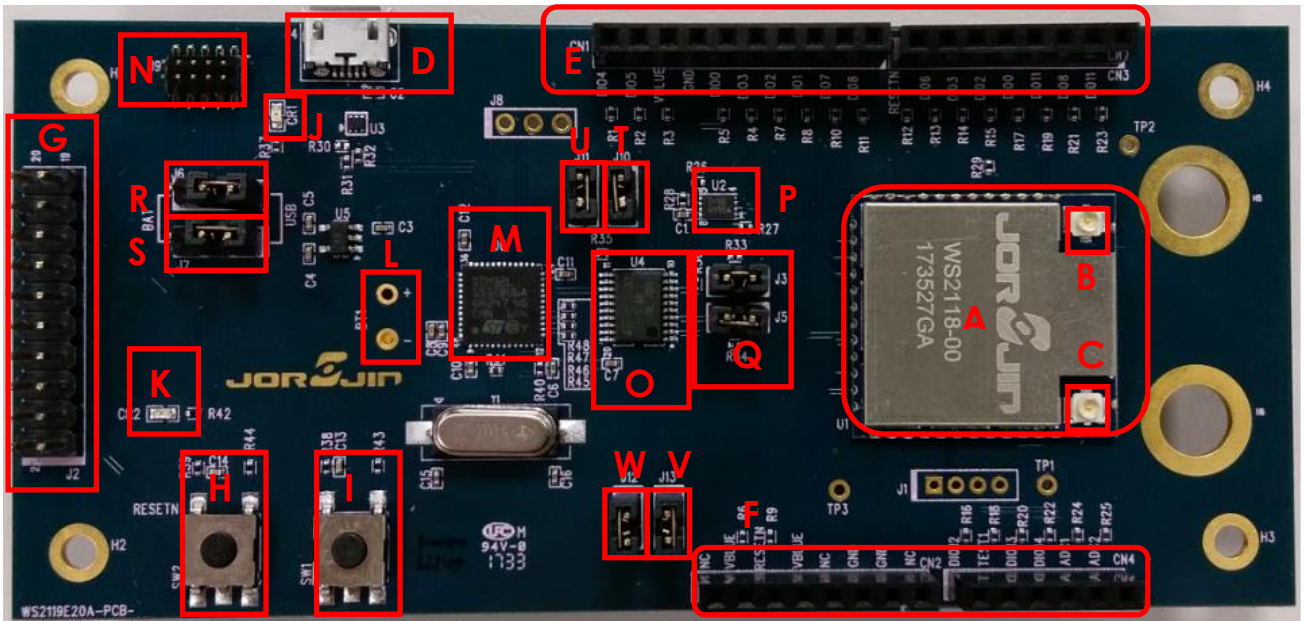

Table 1: WS2118E00 board component descriptions

Region	Description
A	WS2118-00 module
B	BLE RF signal U.FL connector
C	Sub-1GHz RF signal U.FL connector
D	Micro USB connector for power supply and I/O
E,F	Two rows of Arduino-compliant connectors
G	JTAG connector for BlueNRG-1
H	RESET button
I	USER button
J	PWR LED
K	User LED
L	Battery power input point
M	STM32L151CUB6 48-pin microcontroller (USB to serial bridge for I/O channel to PC communication) ⁽¹⁾

N	JTAG connector for STM32L151CUB6 ⁽¹⁾
O	ST2378E level translator to adapt voltage level between STM32 and BlueNRG-1
P	EEPROM
Q	Serial port connection jumpers
R,S	Power source selection jumpers.
T	DIO6 function selection jumper.
U	Current measurement jumper for BlueNRG-1
V	Current measurement jumper for S2LP
W	No function

(1) STM32 is not intended to be programmed by users

3.2. WS2118-00 module connections

The WS2118-00 dual band module (Figure 2: "WS2118E00 board components" – region A) has 2 RF signal connector. One is for BLE (region B), another is for sub-1GHz RF(region C).

The microcontroller of BlueNRG-1 is connected to various components such as buttons, and LEDs. The following table describes the microcontroller pin functions.

Table 2: WS2118-00 module pin description with board functions

Pin Name	Pin No	Function	Arduino Connectors			
			CN1	CN2	CN3	CN4
GND	1	GND	Pin7	Pin6,7		
RESETN	2	System reset		Pin3	Pin8	
DIO13	3	S2-LP for interrupt				Pin3
DIO12	4	User button input				Pin1
TEST	5	Test pin put to GND				
DIO11	6	UART RX from STM32			Pin1,3	
DIO10	7	JTMS-SWTDIO				
DIO9	8	JTCK-SWTCK				
DIO8	9	UART TX to STM32	Pin1		Pin2	
GND	10	GND	Pin7	Pin6,7		
VBAT	11	Power for BlueNRG-1	Pin8	Pin2,4		
GND	12	GND	Pin7	Pin6,7		
DIO7	13	Bootloader pin / LED driver	Pin2			

DIO6	14	RESET pin of STSAFE-A1SX or EEPROM_CS pin			Pin7	
DIO5	15	SDA pin of STSAFE-A1SX	Pin9			
DIO4	16	SCL pin of STSAFE-A1SX	Pin10			
DIO3	17	SDO pin of S2-LP and EEPROM	Pin5		Pin6	
DIO2	18	SDI pin of S2-LP and EEPROM	Pin4		Pin5	
DIO1	19	CS pin of S2-LP	Pin3			
DIO0	20	SCLK pin of S2-LP and EEPROM	Pin6		Pin4	
DIO14	21	SDN pin of S2-LP				Pin4
ANATEST1	22					Pin2
ADC1	23					Pin5
GND	24	GND	Pin7	Pin6,7		
ADC2	25					Pin6
GND	26	GND	Pin7	Pin6,7		
VCC_S2LP	27	Power for S2-LP	Pin8	Pin2,4		
GND	28	GND	Pin7	Pin6,7		
GPIO3	29	S2-LP for interrupt				Pin3
GPIO2	30	GPIO2 of S2LP				
GPIO1	31	GPIO1 of S2LP				
GPIO0	32	GPIO0 of S2LP				
NC	33	No Connection				
NC	34	No Connection	Pin8	Pin2,4		
NC	35	No Connection	Pin8	Pin2,4		
GND	36	GND	Pin7	Pin6,7		

3.3. Power supply

Green LED CR1 (Figure 2: WS2118E00 board components" – region J) signals the board is being powered, either via:

- micro USB connector J4 (Figure 2: WS2118E00 board components" – region D)
- batteries(region L)
- an external DC power supply plus micro USB connector

The following table describes the power supply modes available on the WS2118E00 board and corresponding jumper settings.

Table 3: WS2118E00 kit platform power supply modes

Power supply mode	J7	J6	Comment
1- USB	Fitted:1-2	Fitted:2-3	USB supply through connector J4 (region D)
2- Battery	Fitted:2-3	Fitted:1-2	The supply voltage must be provided through battery pins (region L)
3- Combo	Fitted:1-2	Optional	USB supply through connector J4 for STM32L1; J6 pin 2 external power for WS2118-00 module

3.4. Other jumpers

The following jumpers are available:

Table 4: WS2118E00 kit platform jumpers

Jumper	Description
J1	Test points for S2-LP GPIO0 – GPIO3
J3	UART TX of BlueNRG-1 is connected (Fitted) or disconnected (Not fitted) to STM32.
J5	UART RX of BlueNRG-1 is connected (Fitted) or disconnected (Not fitted) to STM32.
J8	pin 1 and 2 UART RX and TX of MCU pin 3 GND
J10	DIO6 of BlueNRG-1 is connected (Fitted) or disconnected (Not fitted) to EEPROM_CS pin.
J11	Fitted: to provide VBLUE to BlueNRG-1. It can be used also for current measurement.
J12	This jumper is no function in WS2118E00.
J13	Fitted: to provide VBLUE to S2LP. It can be used also for current measurement.

3.5. Extension connectors

WS2118-00 module signal test points are shared on two Arduino-compliant connector rows: CN1, CN3 (Figure 2: "WS2118E00 board components" – region E) and CN2, CN4 (region F). See Table 2: "WS2118-00 module pin description with board functions".

You can also install some sensor module board in the WS2118E00 kit platform through these extension connectors. Please contact Jorjin to get more information.

3.6. Push-buttons

The board has one user button to reset the microcontroller (Figure 2: "WS2118E00 board components" – region H) and one further button for application purposes (region I).

3.7. JTAG connector

A JTAG connector (Figure 2: "WS2118E00 board components" – region G) allows BlueNRG-1 microcontroller programming and debugging with an in-circuit debugger and programmer such as ST-LINK/V2.

Only SWD mode is supported.

3.8. LEDs

LEDs CR1 (green, power LED) and CR2 (red) are available on the board (Figure 2: "WS2118E00 board components" – regions J and K).

3.9. STM32L151CUB6 microcontroller

The most important feature of the STM32L151CUB6 48-pin microcontroller (Figure 2: "WS2118E00 board components" – regions M) is the USB to serial bridge providing an I/O channel with the BlueNRG-1 device.

The microcontroller is connected to the BlueNRG-1 device through an ST2378E level translator (region O).

The STM32L microcontroller on the board is not intended to be programmed by users. ST provides a pre-programmed firmware image for the sole purpose of interfacing BlueNRG-1 to a USB host device (e.g., a PC). The JTAG connector (Figure 2: "WS2118E00 board components" – regions N) is only for Jorjin internal used.

3.10. Hardware setup

1. Connect one 2.4GHz antenna to BLE U.FL connector (Figure 2: "WS2118E00 board components" – regions B). Connect one 868MHz antenna to Sub-1GHz U.FL connector (regions C)

2. Configure the board to USB power supply mode as per the jumper settings in Table 3: “WS2118E00 kit platform power supply modes”
3. Connect the board to a PC via USB cable (connector J4)
4. Verify the power indication LED CR1 is on.

Figure 4: WS2118E00 JTAG

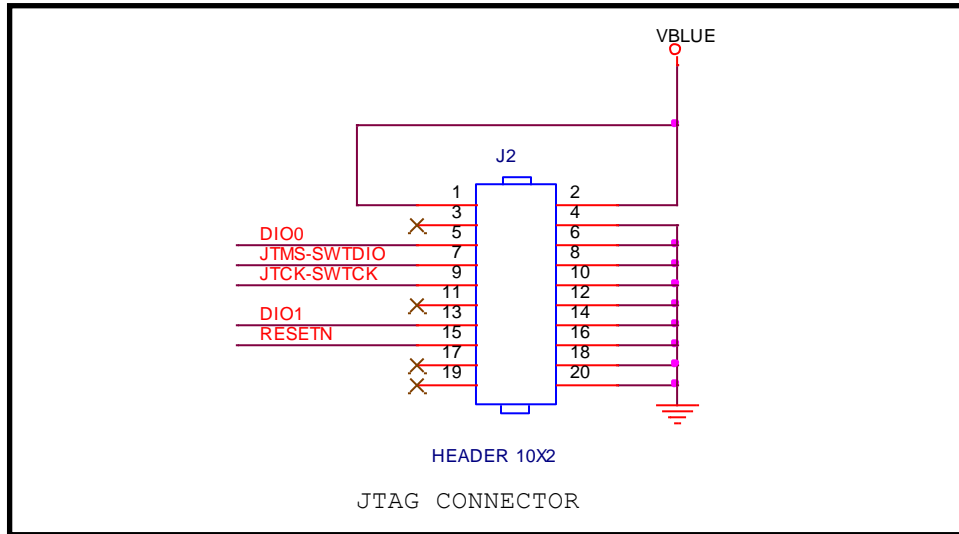

Figure 5: WS2118E00 WS2118-00 module

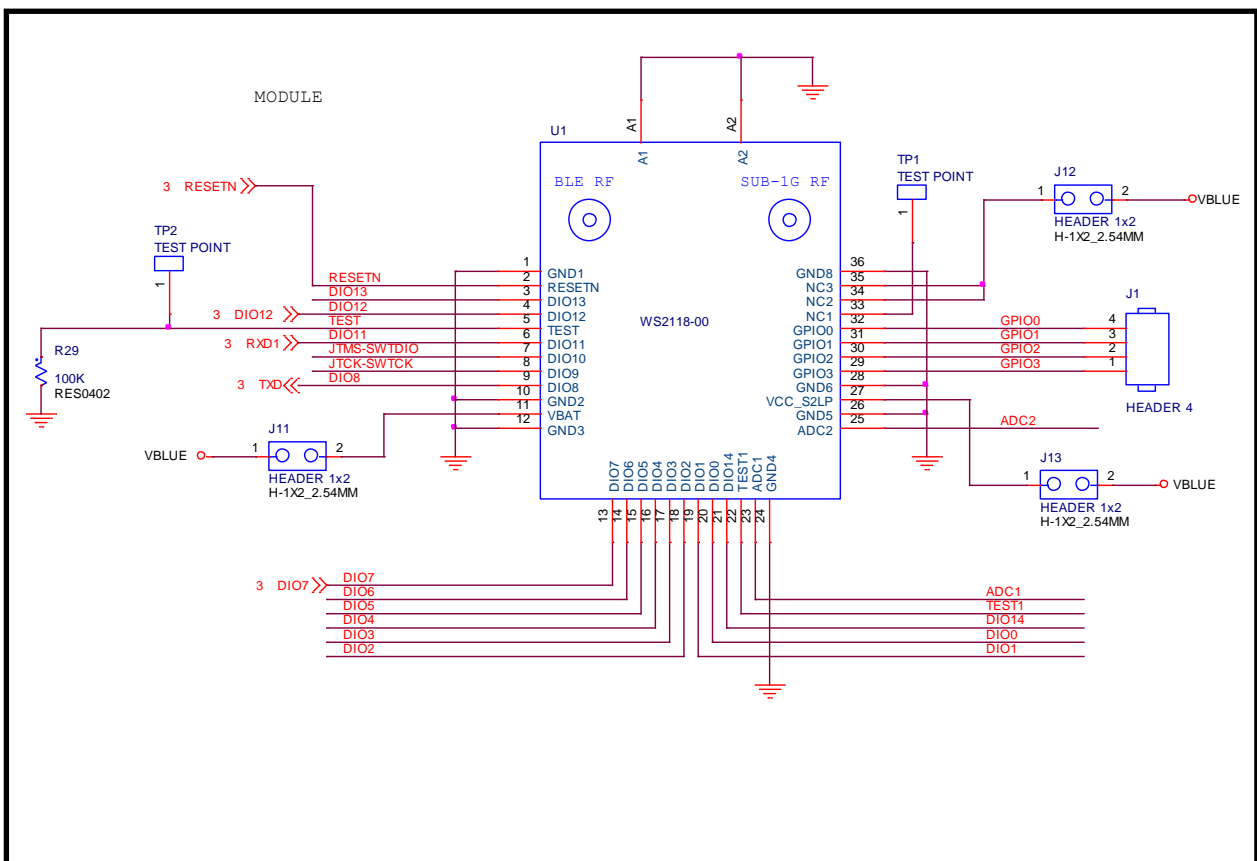

Figure 6: WS2118E00 Power circuit

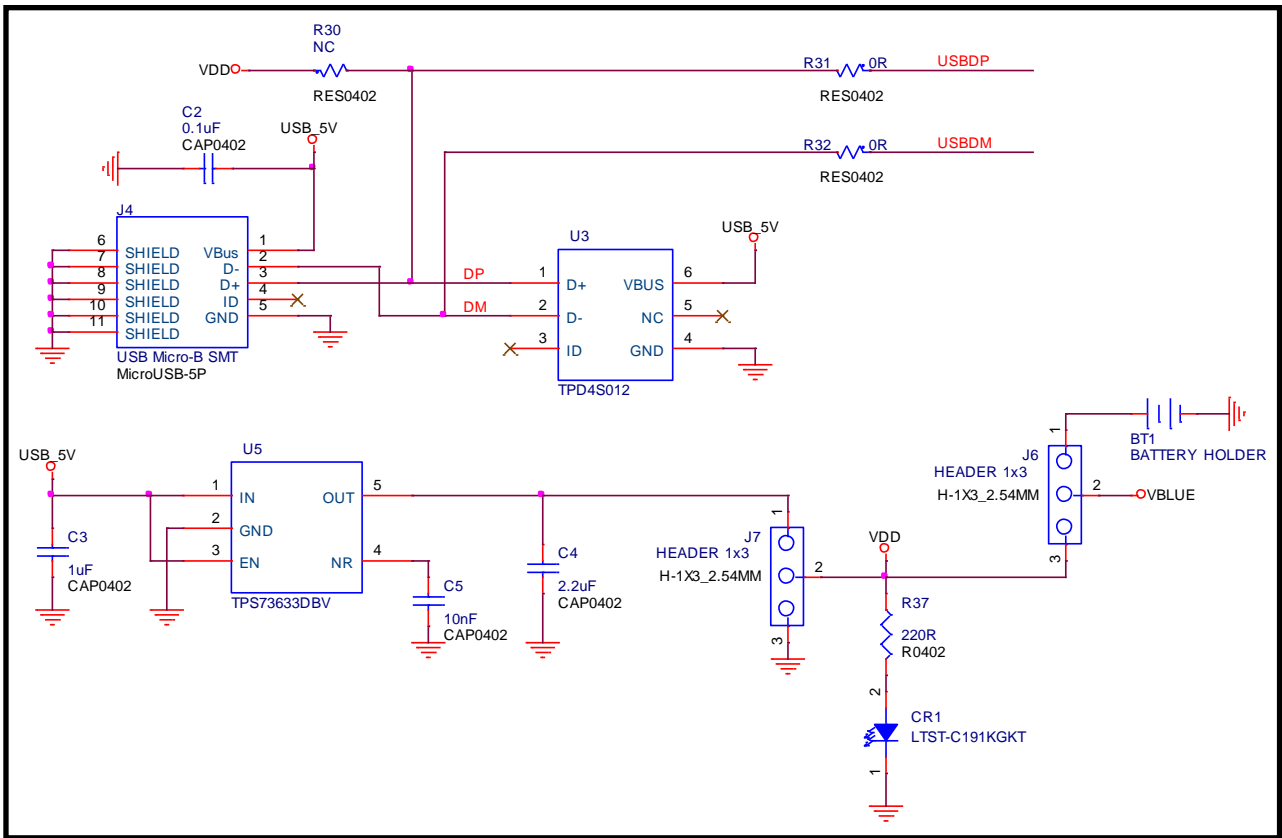

Figure 7: WS2118E00 Level translator

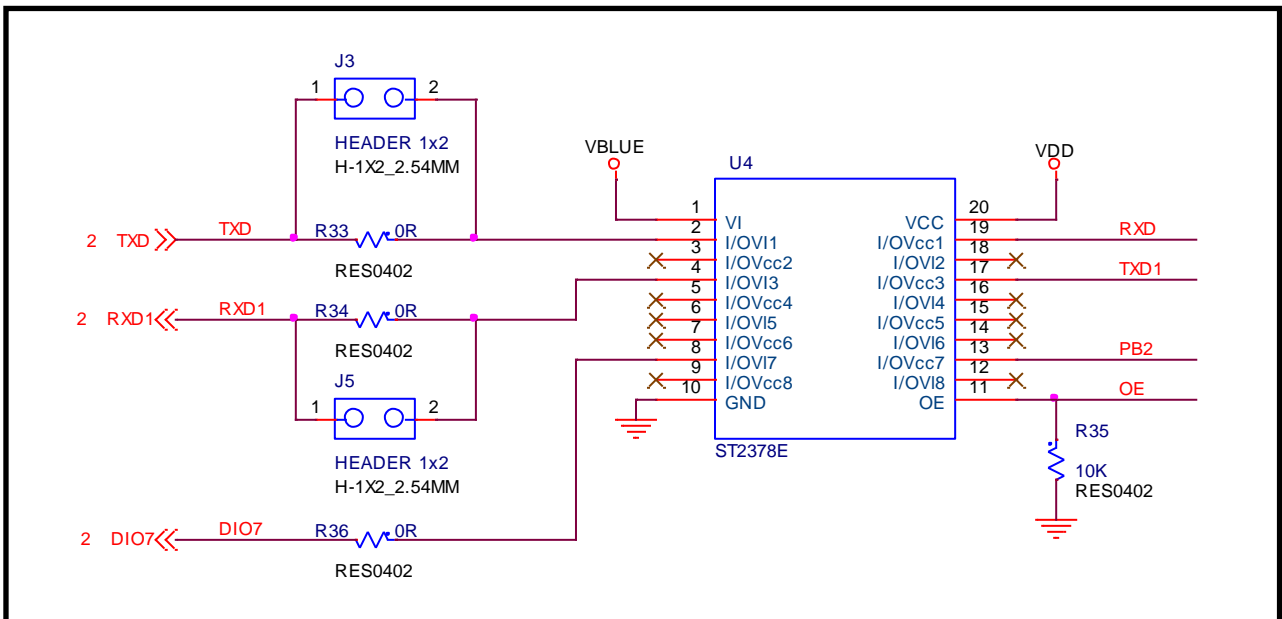

Figure 8: WS2118E00 Micro Controller

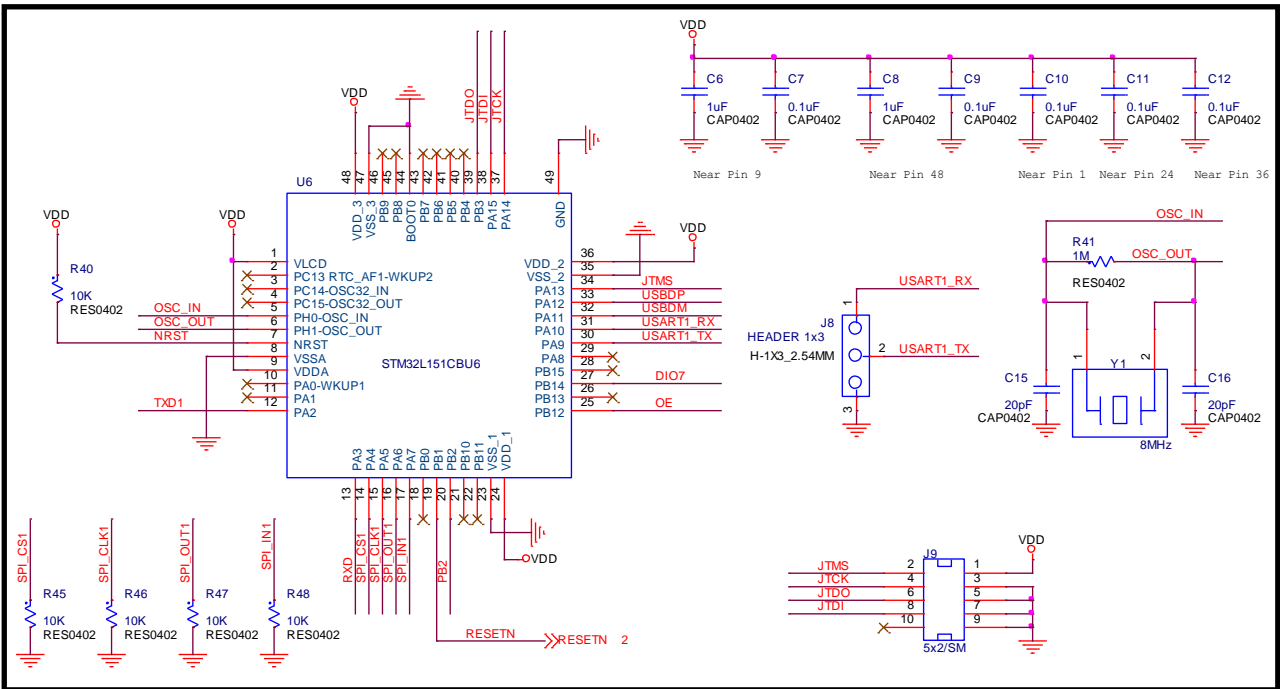
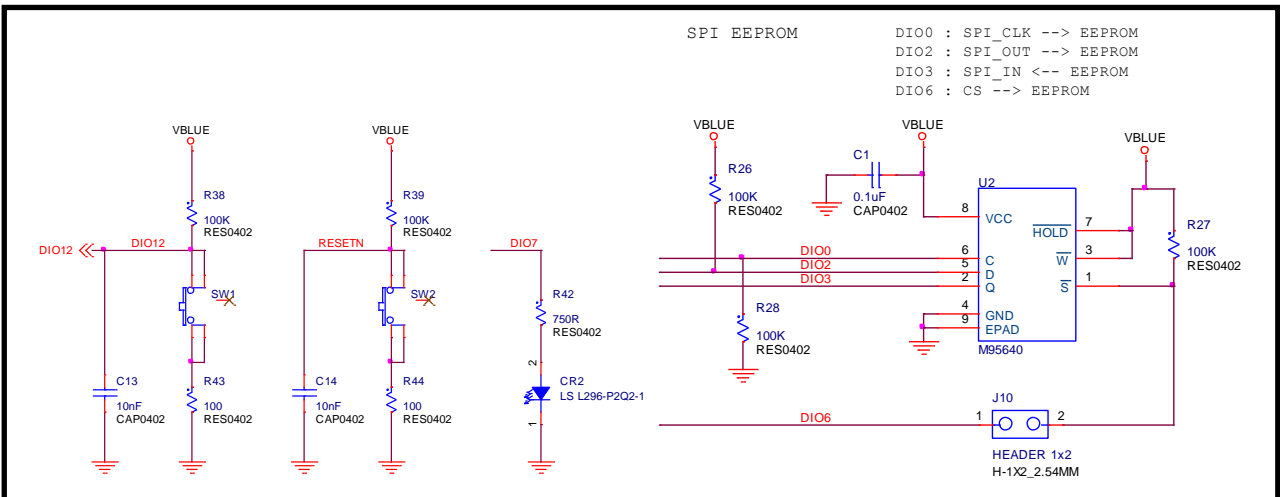

Figure 9: WS2118E00 LED, Switch, and EEPROM



5. HISTORY CHANGE

Revision	Date	Description
D 0.1	2017/Sep/19	Initial release
D 0.2	2018/Jan/04	Updated to D04 design