



Biased Detector, SMA, Negative Video Out, 8 GHz to 16 GHz

Detectors Technical Data Sheet

PE8007

The PE8007 is a biased Schottky detector that displays an extremely flat frequency response over a broad frequency range from 8 GHz to 16 GHz. An External DC Bias Circuit is required (reference application circuit). Biasing offers optimum rectification performance of the Schottky Junction. The model features negative video output polarity and operates to +23dBm input power with a TSS of -52dBm. Additional features include 50 ohm matched inputs, and high voltage sensitivity for very small signal detection of 1800 mV/mW. Operating temperature range is -55°C to +125°C. The compact and rugged cylindrical package supports an SMA male input connector and SMA female output connector and is ideal for use with precision test and measurement, instrumentation, and subsystem assemblies.

Features

- Biased Schottky Diode Detector
- TSS:-52 dBm
- 8 GHz to 16 GHz Frequency Range
- Extremely Flat Frequency Response
- Maximum Input Power +23 dBm
- Negative Video Output Polarity
- Bias: 100uA typical
- External DC Bias Circuit is Required (reference application circuit)
- High Voltage Sensitivity

Applications

- Electronic Warfare
- Test & Measurement
- System Monitoring
- AM Noise Measurements
- Military & Space
- Radar
- Pulsed RF Measurements in Ultra Broadband Applications
- Leveling Pulse Signal Sources
- Military Communications Systems

Electrical Specifications

Description	Minimum	Typical	Maximum	Units
Frequency Range	8 GHz		16 GHz	
Voltage Sensitivity		1,800		mV/mW
Flatness		±0.6		dB
Input Power			+23	dBm
Tangential Signal Sensitivity (TSS)		-52		dBm
Operating Temperature Range	-55		+125	deg C

Electrical Specification Notes:

@ +25 deg C, 100uA Bias, and -20 dBm Pin

Voltage Sensitivity is that of an open circuit

TSS is measured with a 2 MHz video bandwidth and a 2 dB NF Amplifier

Mechanical Specifications

Size

Length	1.32 in [33.53 mm]
Width	0.323 in [8.2 mm]
Weight	0.017 lbs [7.71 g]

Click the following link (or enter part number in "SEARCH" on website) to obtain additional part information including price, inventory and certifications: [Biased Detector, SMA, Negative Video Out, 8 GHz to 16 GHz PE8007](#)



Biased Detector, SMA, Negative Video Out, 8 GHz to 16 GHz

Detectors Technical Data Sheet

PE8007

Environmental Specifications

Temperature

Operating Range

-55 to +125 deg C

Storage Range

-65 to +125 deg C

Compliance Certifications (see [product page](#) for current document)

Plotted and Other Data

Notes:

Click the following link (or enter part number in "SEARCH" on website) to obtain additional part information including price, inventory and certifications: [Biased Detector, SMA, Negative Video Out, 8 GHz to 16 GHz PE8007](#)



Biased Detector, SMA, Negative Video Out, 8 GHz to 16 GHz

Functional Block Diagram

Biased Schottky Detector Application Circuit

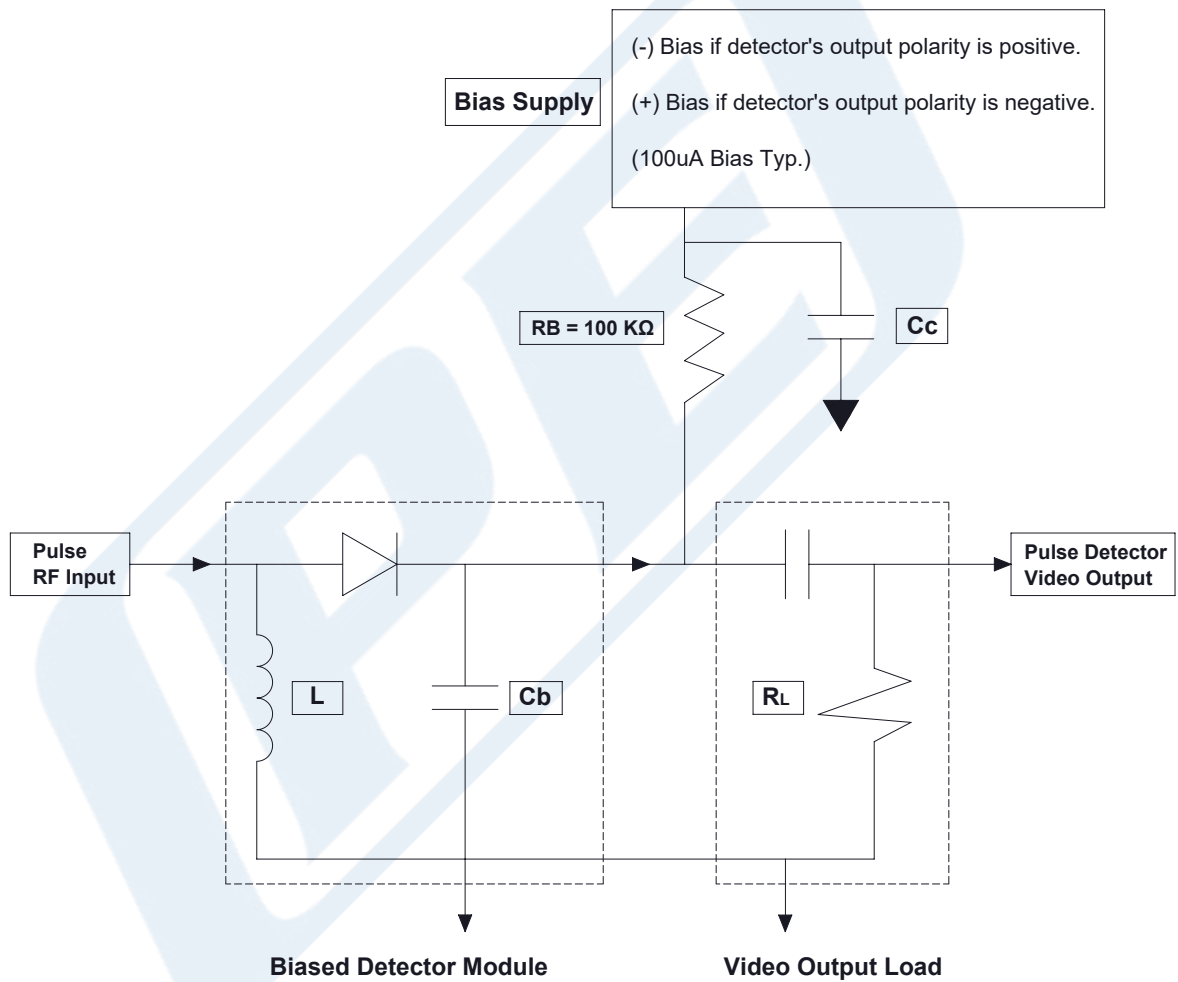

Click the following link (or enter part number in "SEARCH" on website) to obtain additional part information including price, inventory and certifications: [Biased Detector, SMA, Negative Video Out, 8 GHz to 16 GHz PE8007](#)



Biased Detector, SMA, Negative Video Out, 8 GHz to 16 GHz

Detectors Technical Data Sheet

PE8007

Typical Performance Data

TRANSFER CHARACTERISTIC

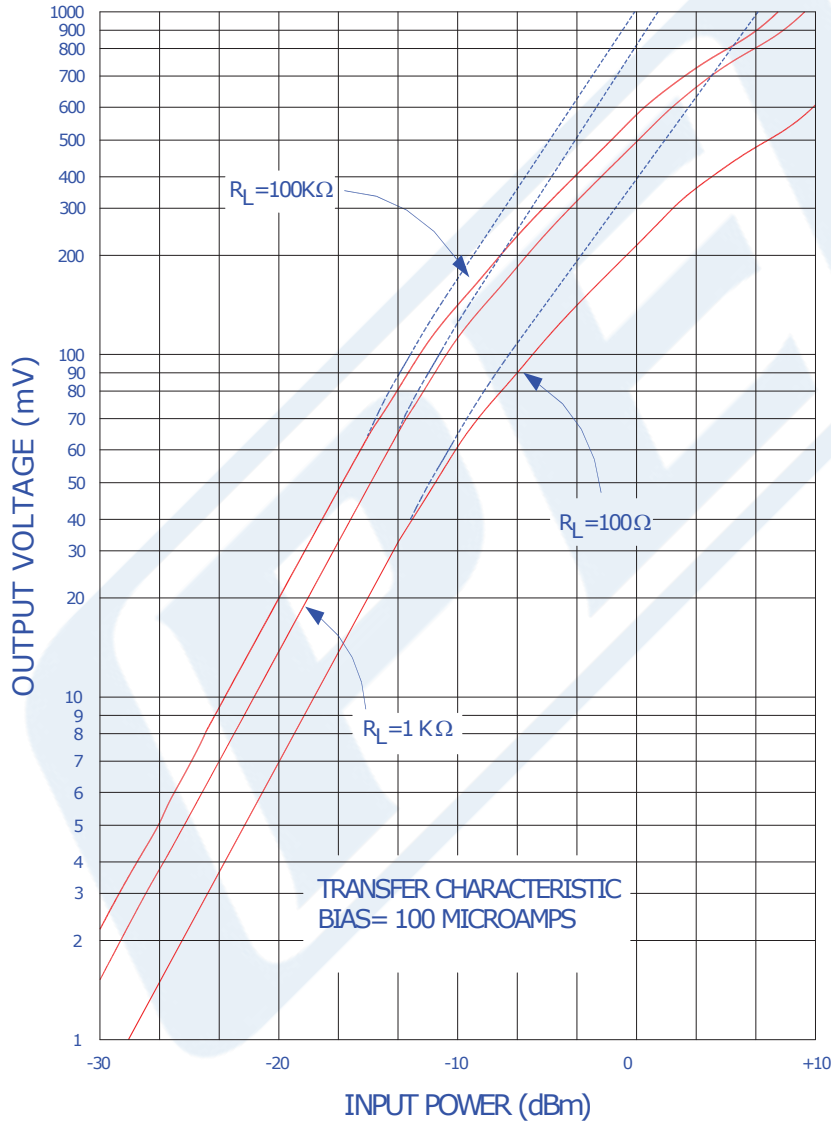

Click the following link (or enter part number in "SEARCH" on website) to obtain additional part information including price, inventory and certifications: [Biased Detector, SMA, Negative Video Out, 8 GHz to 16 GHz PE8007](#)



Biased Detector, SMA, Negative Video Out, 8 GHz to 16 GHz

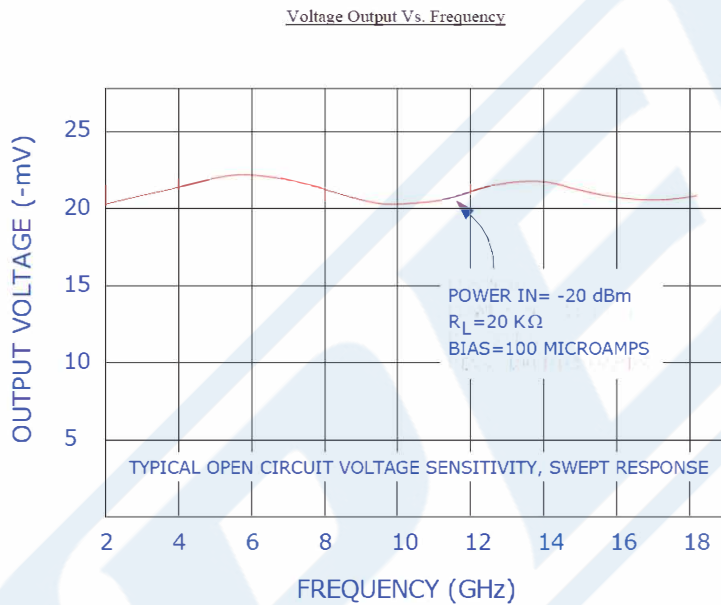

Click the following link (or enter part number in "SEARCH" on website) to obtain additional part information including price, inventory and certifications: [Biased Detector, SMA, Negative Video Out, 8 GHz to 16 GHz PE8007](#)



Biased Detector, SMA, Negative Video Out, 8 GHz to 16 GHz

Detectors Technical Data Sheet

PE8007

Biased Detector, SMA, Negative Video Out, 8 GHz to 16 GHz from Pasternack Enterprises has same day shipment for domestic and International orders. Our RF, microwave and millimeter wave products maintain a 99.4% availability and are part of the broadest selection in the industry.

Click the following link (or enter part number in "SEARCH" on website) to obtain additional part information including price, inventory and certifications: [Biased Detector, SMA, Negative Video Out, 8 GHz to 16 GHz PE8007](#)

URL: <https://www.pasternack.com/negative-biased-schottky-diode-detector-80-160-ghz-pe8007-p.aspx>

The information contained in this document is accurate to the best of our knowledge and representative of the part described herein. It may be necessary to make modifications to the part and/or the documentation of the part, in order to implement improvements. Pasternack reserves the right to make such changes as required. Unless otherwise stated, all specifications are nominal. Pasternack does not make any representation or warranty regarding the suitability of the part described herein for any particular purpose, and Pasternack does not assume any liability arising out of the use of any part or documentation.

PE8007 CAD Drawing

Biased Detector, SMA, Negative Video Out, 8 GHz to 16 GHz

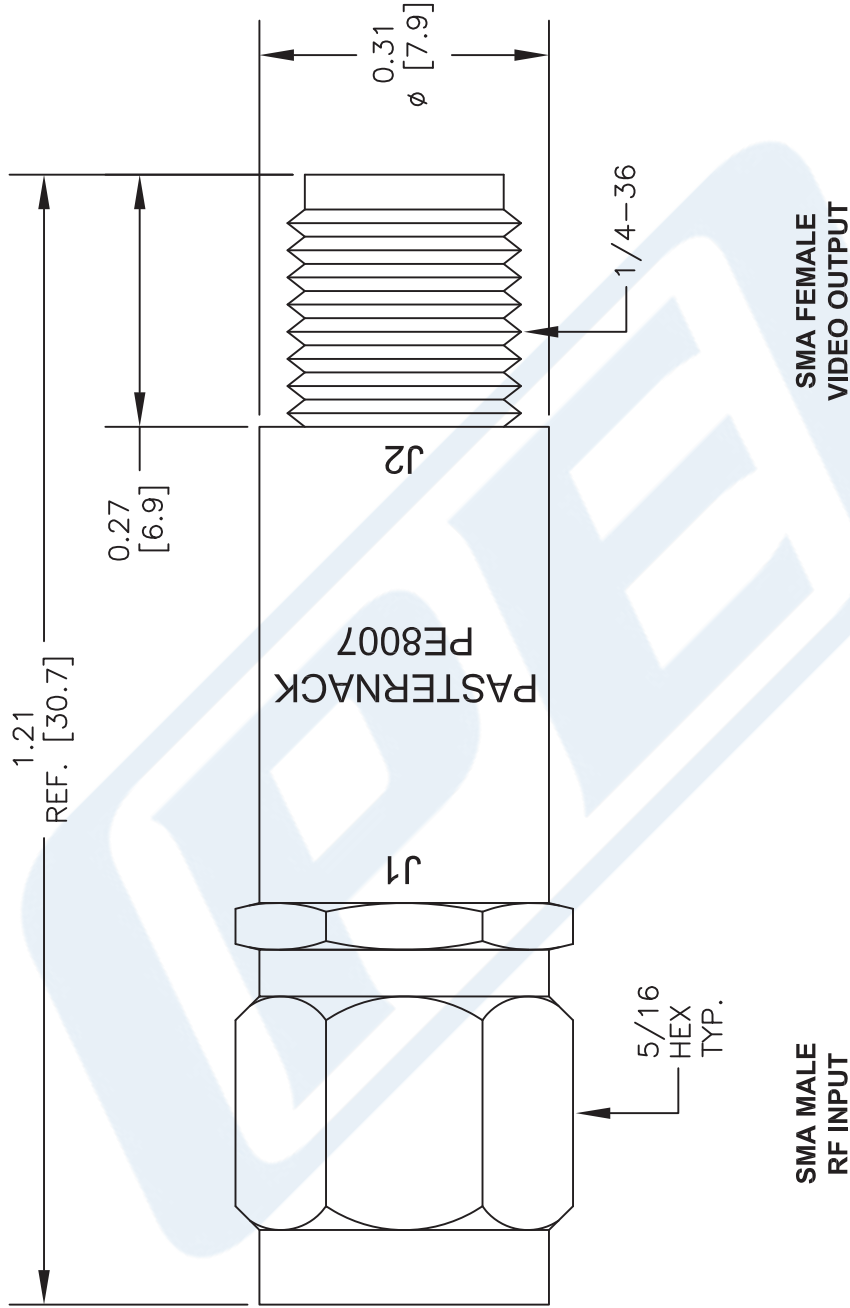

SMA MALE
RF INPUT

SMA FEMALE
VIDEO OUTPUT

DWG TITLE

PE8007

NOTES:
1. UNLESS OTHERWISE SPECIFIED ALL DIMENSIONS ARE NOMINAL.
2. ALL SPECIFICATIONS ARE SUBJECT TO CHANGE WITHOUT NOTICE AT ANY TIME.
3. DIMENSIONS ARE IN INCHES [mm].

FSCM NO. 53919

CAD FILE 090313

SCALE N/A

SIZE A

2233



PASTERNAK[®]
Pasternack Enterprises, Inc.
P.O. Box 16759 | Irvine | CA | 92623
Phone: (949) 261-1920 | Fax: (949) 261-7451
Website: www.pasternack.com | E-Mail: sales@pasternack.com