

General Description:

This system is a broadband power amplifier designed for CW/Digital/Pulse signals and general-purpose amplification. Using advanced high power density LDMOS and GaN semiconductor devices, these high-performance amplifiers achieve high efficiency, high gain, and wide dynamic range. Like all Elite RF amplifiers, the product comes with an industry leading **3-year warranty**

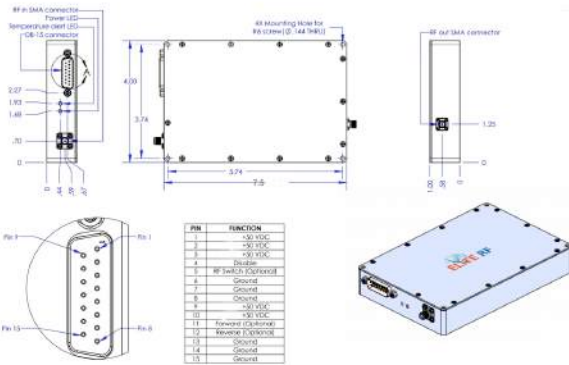

Features

0.5 – 2.5 GHz
50 watts
45 dB gain
Class AB
50 VDC
On/Off Enable- Ground to disable amplifier

Indicator options

DC Power
Temp Fault

Protections

Thermal Overload
Over Voltage
Reverse Polarity

ELECTRICAL SPECIFICATIONS

Parameter	Symbol	Min	Typ	Max	Unit
Frequency Range	BW	0.5		2.5	GHz
Output Power CW	Psat		50		Watt
Output Power at 1 dB Compression	P3dB		25		Watt
Small Signal Gain	Gp		45		dB
Gain Flatness @ Psat	Delta Gp 1		+/- 2		dB
Input VSWR	S11		2:1		-
IMD @ 1.5 GHz @ 30 dBm/ tone	IP3		55		dBm
Harmonics at 50 Watts	H		-20		dBc
Spurious Signals	Spur		-60		dBc
Operating Voltage	VDC	48	50	51	VDC
Current at 50 watts	Current		4		Amps
Class of Operation	C		AB		Class
Noise Figure	NF		5		dB
Max Load VSWR @ 100 watts	Lm			3:1	Ratio
Large signal gain	Lgs		40		dB

ENVIRONMENTAL CHARACTERISTICS

Parameter	Symbol	Min	Typ	Max	Unit
Operating Case Temperature	Tc	-20		+60	Deg C
Storage Temperature	Tstg	-40		+85	Deg C
Relative Humidity (non-condensing)	RH			95	%
Altitude	ALT			10,000	Feet
Vibration/Shock	VI /SH			Normal Truck Transport	

MECHANICAL CHARACTERISTICS

Parameter	Symbol	Min	Typ	Max	Unit
Dimensions	Dim		7.5 x 4 x 1		Inches
Weight	Wt.		2		lbs.
Connectors In/Out	RF Conn		SMA/SMA		-
Cooling	Th		Heatsink required		-