



50 Ohm SMA Male to 75 Ohm F Female Matching Pad Operating from DC to 3 GHz

Matching Pads Technical Data Sheet

PE70MP1108

Features

- DC to 3 GHz Frequency Range
- Low VSWR < 1.25:1
- 0.5 W Max Power (CW)

Applications

- CATV / Cable Networks
- Communication Systems
- Test and Measurement
- Wireless Systems

Description

Pasternack's PE70MP1108 is a 50 ohm SMA male to 75 ohm F female matching pad that operates from DC to 3 GHz. This SMA to F impedance matching pad offers a low VSWR of 1.25:1 max and attenuation of 7.5 dB max. PE70MP1108 50 ohm to 75 ohm minimum loss pad has a maximum CW power rating of 0.5 Watt. Matching pads are used to match the different impedance between two devices, maximizing power transfer between the two impedances. Pasternack's minimum loss impedance matching pads are available in various connector combinations to fit your needs, all of which ship the same day.

Configuration

Connector 1 50 Ohms SMA Male
 Connector 2 75 Ohms F Female

Electrical Specifications

Description	Minimum	Typical	Maximum	Units
Frequency Range	DC		3	GHz
VSWR		1.15:1	1.25:1	
Attenuation		4	7.5	dB
Input Power (CW)			0.5	Watts

Electrical Specification Notes:

Impedance Matching Pads are resistive devices and are not designed as DC Pass or DC Block circuits

Mechanical Specifications

Size

Length 1.9 in [48.26 mm]
 Width 0.49 in [12.45 mm]
 Height 0.49 in [12.45 mm]
 Weight 0.04 lbs [18.14 g]
 Housing Material and Plating Brass, Tri-Metal

Click the following link (or enter part number in "SEARCH" on website) to obtain additional part information including price, inventory and certifications: [50 Ohm SMA Male to 75 Ohm F Female Matching Pad Operating from DC to 3 GHz PE70MP1108](#)



50 Ohm SMA Male to 75 Ohm F Female Matching Pad Operating from DC to 3 GHz

Matching Pads Technical Data Sheet

PE70MP1108

Connectors

Description	Connector 1	Connector 2
Type	SMA Male	F Female
Impedance	50 Ohms	75 Ohms
Inner Conductor Material and Plating	Brass, Gold	Beryllium Copper, Gold
Body Material and Plating	Brass, Tri-Metal	Brass, Tri-Metal

Compliance Certifications (see [product page](#) for current document)

Plotted and Other Data

Notes:

50 Ohm SMA Male to 75 Ohm F Female Matching Pad Operating from DC to 3 GHz from Pasternack Enterprises has same day shipment for domestic and International orders. Our RF, microwave and millimeter wave products maintain a 99.4% availability and are part of the broadest selection in the industry.

Click the following link (or enter part number in "SEARCH" on website) to obtain additional part information including price, inventory and certifications: [50 Ohm SMA Male to 75 Ohm F Female Matching Pad Operating from DC to 3 GHz PE70MP1108](#)

URL: <https://www.pasternack.com/sma-f-matching-pad-3-mhz-pe70mp1108-p.aspx>

The information contained in this document is accurate to the best of our knowledge and representative of the part described herein. It may be necessary to make modifications to the part and/or the documentation of the part, in order to implement improvements. Pasternack reserves the right to make such changes as required. Unless otherwise stated, all specifications are nominal. Pasternack does not make any representation or warranty regarding the suitability of the part described herein for any particular purpose, and Pasternack does not assume any liability arising out of the use of any part or documentation.

PE70MP1108 CAD Drawing

50 Ohm SMA Male to 75 Ohm F Female Matching Pad Operating from DC to 3 GHz

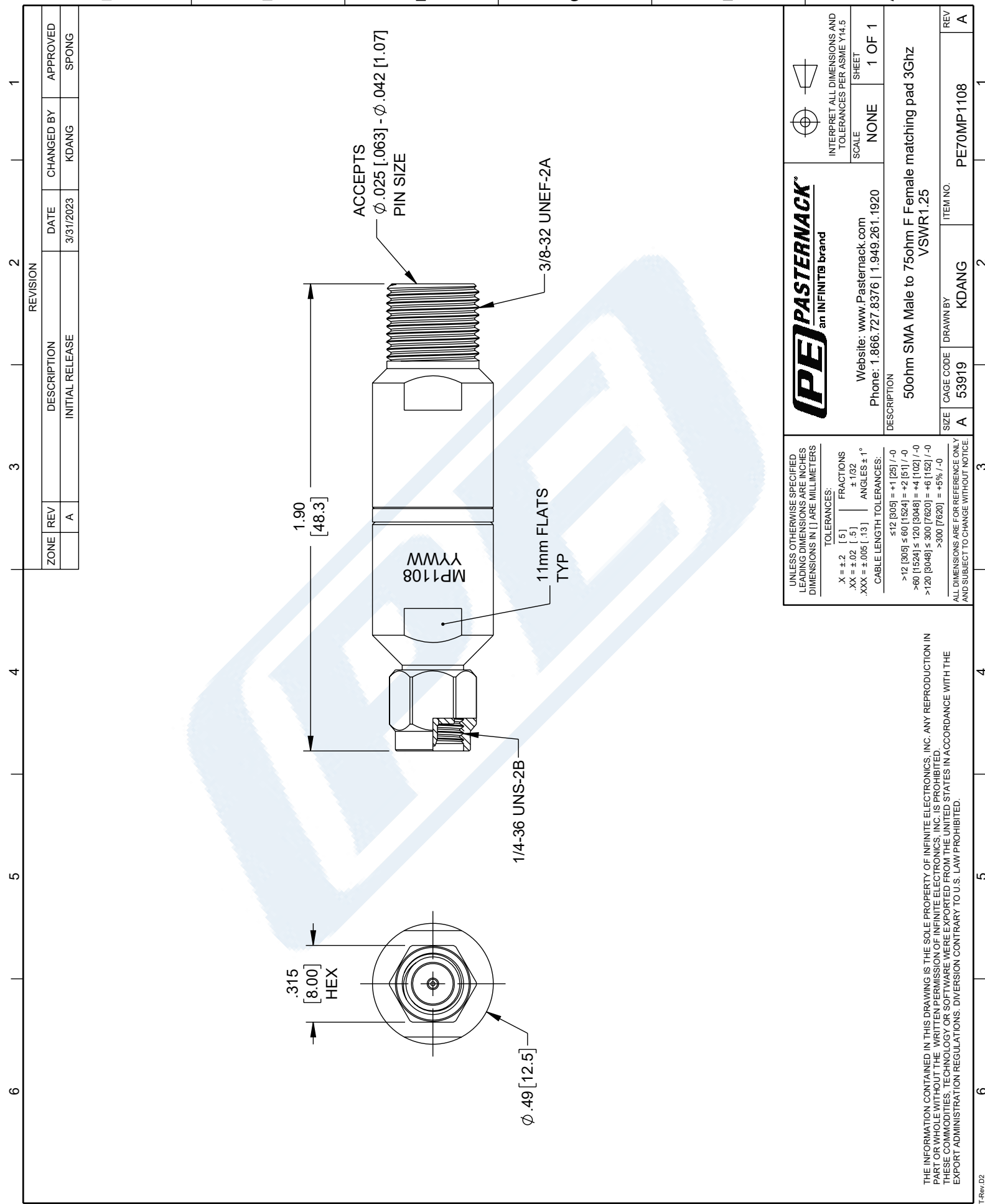

ZONE	REV	DESCRIPTION	DATE	CHANGED BY	APPROVED
	A	INITIAL RELEASE	3/31/2023	KDANG	SPONG

<p>an INFINITIB® brand</p> <p>Website: www.Pasternack.com Phone: 1.866.727.8376 1.949.261.1920</p>	<p>INTERPRET ALL DIMENSIONS AND TOLERANCES PER ASME Y14.5</p>
	<p>SCALE: NONE</p> <p>SHEET: 1 OF 1</p>
<p>DESCRIPTION</p> <p>50ohm SMA Male to 75ohm F Female matching pad 3Ghz VSWR1.25</p>	
<p>UNLESS OTHERWISE SPECIFIED LEADING DIMENSIONS ARE INCHES DIMENSIONS IN [] ARE MILLIMETERS</p> <p>TOLERANCES:</p> <p>X = ±.2 [5] FRACTIONS ± 1/32</p> <p>.XX = ±.02 [.5] ANGLES ± 1°</p> <p>.XXX = ±.005 [.13]</p> <p>CABLE LENGTH TOLERANCES:</p> <p>≤12 [305] = +1 [25] / -0</p> <p>>12 [305] ≤ 60 [1524] = +2 [51] / -0</p> <p>>60 [1524] ≤ 120 [3048] = +4 [102] / -0</p> <p>>120 [3048] ≤ 300 [7620] = +6 [152] / -0</p> <p>>300 [7620] = +5% / -0</p> <p>ALL DIMENSIONS ARE FOR REFERENCE ONLY AND SUBJECT TO CHANGE WITHOUT NOTICE.</p>	<p>ITEM NO. PE70MP1108</p> <p>REVISION A</p>

THE INFORMATION CONTAINED IN THIS DRAWING IS THE SOLE PROPERTY OF INFINITE ELECTRONICS, INC. ANY REPRODUCTION IN PART OR WHOLE WITHOUT THE WRITTEN PERMISSION OF INFINITE ELECTRONICS, INC. IS PROHIBITED. THESE COMMODITIES, TECHNOLOGY OR SOFTWARE WERE EXPORTED FROM THE UNITED STATES IN ACCORDANCE WITH THE EXPORT ADMINISTRATION REGULATIONS. DIVERSION CONTRARY TO U.S. LAW PROHIBITED.