

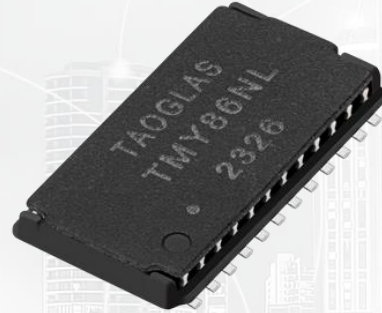

TAOGLAS®

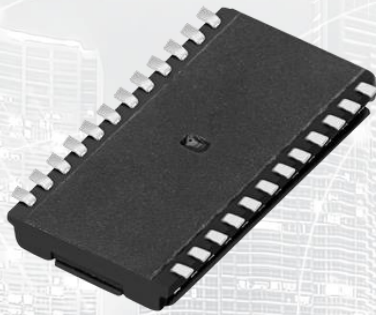

Datasheet

LAN Transformer 1G Base-T PCMCIA PoE

Part No:
TMY86NL

Description:

1G Base-T transformer
Single Port and 24pin SMT with PoE

Features:

PoE (350mA)
Transformer + CMC
Low Profile
Industrial grade
RoHS Compliant

1. Introduction	3
2. Specifications	4
3. Mechanical	5
4. Electrical	6
5. Packaging	7
<hr/>	
Changelog	8

Taoglas makes no warranties based on the accuracy or completeness of the contents of this document and reserves the right to make changes to specifications and product descriptions at any time without notice. Taoglas reserves all rights to this document and the information contained herein. Reproduction, use or disclosure to third parties without express permission is strictly prohibited.



1. Introduction



Featuring a compatible footprint with industry LAN transformers, and designed to work in demanding industrial environmental conditions, the Taoglas TMY86NL is a LAN Transformer 1GBase-T Single Port of 24pins that is capable to work in industrial environmental conditions and offer PoE capabilities with PCMCIA package design.

Typical applications for this cost-effective part are:

- Industrial Automation
- Hubs
- Routers
- Switches
- Wireless Access Points

The Taoglas Magnetics Product Team have over fifteen years of LAN magnetics design and high-quality manufacturing. With an ever-expanding portfolio, we provide trusted products and services to customers within a wide range of applications such as: Networking and Interconnect Devices, Servers, Switches, Router, Communication systems and any Digital Consumer electronics.

The Taoglas Exos Series offer an extensive product line of LAN Transformers designed for commercial and industrial grade applications, supporting 10/100 Base-T (Exos100 Series), 1G Base-T (Exos1G Series) and 10G Base-T (Exos10G Series). These products include Single, Dual, and Quad configurations not only for standard applications but also for Power over Ethernet (PoE, PoE+, PoE++).

For more information on the range of products or for assistance with integration, contact your regional Taoglas customer support team.

2. Specifications

Electrical Performance @25°C	
Inductance(100KHz/0.1V)	350uH MIN
Turns Ratio (±5%)	1CT: 1CT
Insertion Loss (dB MAX)	-1.1dB (1-100MHz)
Return Loss (dB MIN)	-18dB (0.1-30MHz)
	-14.4dB (40MHz)
	-13.1dB (50MHz)
	-10dB (60-100MHz)
Cross talk	-30dB (1-100MHz)
DCMR (dB MIN)	-40dB (30MHz)
	-35dB (60MHz)
	-30dB (100MHz)
DCR	1.6Ω MAX
POE applications current capability	350mA MAX
Hi-Pot	1500Vrms

Environmental Specifications	
Operating Temperature	-40°C TO +85°C

Compliance	
RoHS Compliant	

Storage requirements	
Humidity	MSL - 1
Storage Temperature	-40°C TO +85°C

3. Mechanical

3.1 Mechanical Drawings

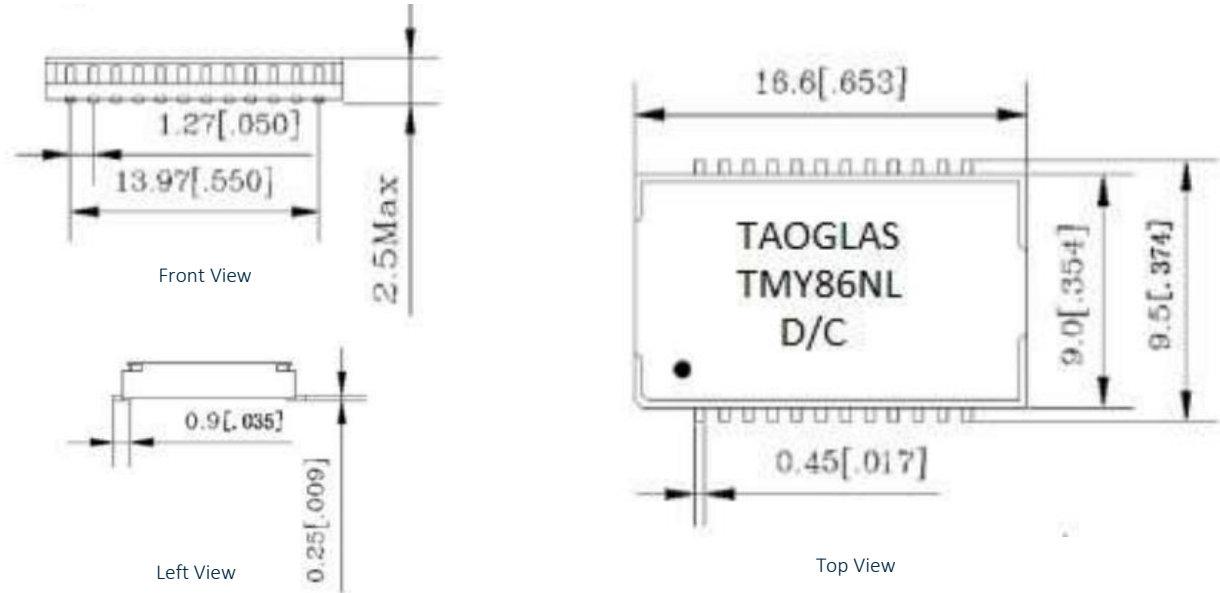

Mechanical Specifications

Length	16.6 mm
Width	9.5 mm
Height	2.5 mm
Mounting Style	Surface Mount (SMT)

Dimensions are in millimeters with the following tolerances: X.XX = ± 0.25

3.2 Pad Layout

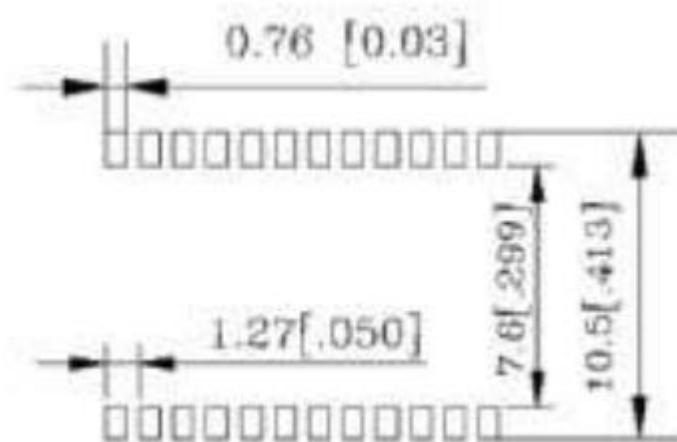

Suggested pad layout

Dimensions are in millimeters with the following tolerances: X.XX = ± 0.10

4. Electrical

4.1 Electrical Drawings

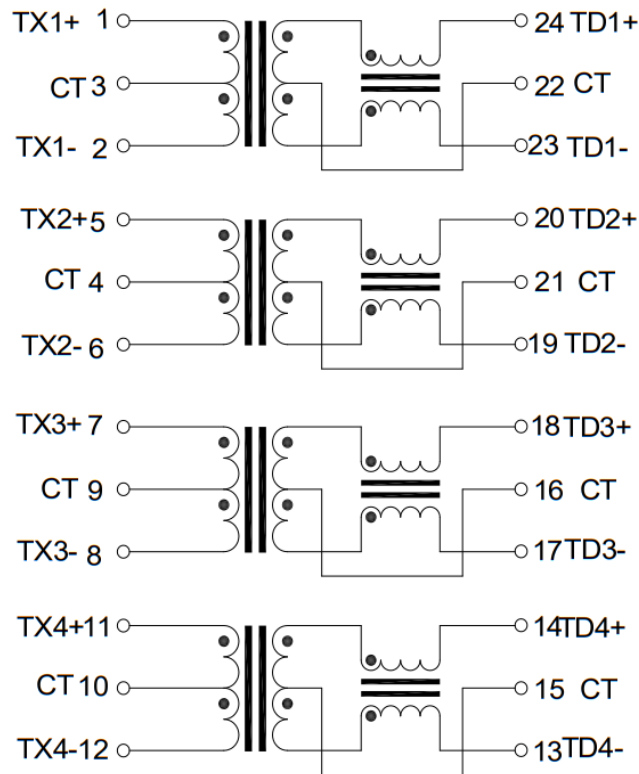

4.2 Profile of Reflow Solder

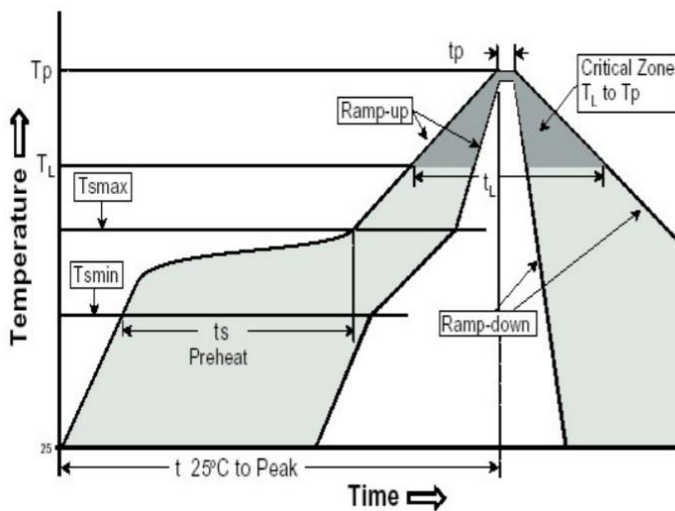

Profile Feature	Pb-Free Assembly
Average Ramp-Up Rate (T_{smin} to T_p)	3°C /second max.
Preheat	
-Temperature Min (T_{smin})	150°C
-Temperature Max (T_{smax})	200°C
-Time (t_{smin} to t_{smax})	60-120 seconds
Time maintained above:	
-Temperature (T_L)	217°C
-Time (t_L)	60-150 seconds
Peak/Classification Temperature (T_p)	240°C MAX
Time within 5°C of actual Peak Temperature (t_p)	20-40 seconds
Ramp-Down Rate	6°C/seconds max
Time 25°C to Peak Temperature	6minutes max.

5. Packaging

5.1 SPQ

1 reel = 1400 pcs

Weight: 0.56g/pcs

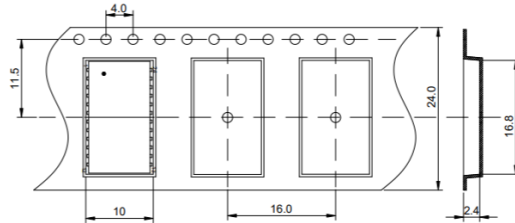

1 Carton = 10 reels = 14000 pcs

Carton dimensions: 365*365*350 mm

Carton Weight: 11.9 kg



5.2 Label

Taoglas Limited	
P/N NO: XXXXXXXX	
QYT: XXX PCS	DC: XXXX
DATE: XXXX-XX-XX	

SPQ Label (8x4cm)

Taoglas Limited	
P/N NO: XXXXXXXX	
PO: XXXXXXXX	B/N: XXXXXXXX
QYT: XXX PCS	DC: XXXX
DATE: XXXX-XX-XX	

Carton Label (8x4cm)

Changelog

Changelog for the datasheet

SPE-23-8-153 – TMY86NL

Revision: A (Original First Release)

Date:	2023-07-01
Notes:	
Author:	Javier Vasena

Previous Revisions



www.taoglas.com

