

TMR3108

17-bit High-speed TMR Magnetic Rotary Encoder

Description

The TMR3108 is a contactless, high-precision, and high-speed magnetic rotary encoder sensor that integrates tunnel magnetoresistance (TMR) sensors and 17-bit signal processing ASIC. It provides options for parameter programming and various output options.

The TMR3108 senses the single pole-pair magnet rotation above the chip by TMR sensors; collects the rotating magnetic field signal; transmits it to the digital processing unit, and calculates the rotation angle. The TMR3108 supports 3-wire and 4-wire SPI operation and outputs 17-bit absolute position signal through SPI communication protocol to the MCU. It also offers a 12-bit PWM output that can be programmed to four PWM frequency.

The TMR3108 provides incremental ABZ output supporting up to 4096 lines. Parameters including A/B phase direction, Z pulse width and positions can also be programmed. The TMR3108 also has UVW output for up to 32 pole-pairs.

The TMR3108 offers a self-calibration function to compensate non-linearities caused by imperfect installation. The TMR3108 is available in TSSOP16 package.

Features and Benefits

- Tunneling magnetoresistance (TMR) technology
- Adaptable voltage range: 3.3 V to 5 V
- Supply current as low as 10 mA (typ.)
- 0° to 360° absolute position sensing
- Available in SPI, ABZ differential, UVW, Analog and PWM interfaces
- Programmable A/B interpolation factors from ×1 to ×4096
- Programmable Z pulse width: 1 to 16384 LSB
- Programmable inverted UVW output resolution in 1 to 32 pole-pair
- Output delay < 2 μs
- Angular error < ±0.2°
- Angular repeatability < ±0.04°
- Speeds up to 40,000 RPM
- Self-calibration available
- Built-in EEPROM supports 10000+ read/write cycles
- RoHS & REACH compliant

Applications

- Contactless angular position measurement
- Brushless motor position sensing
- Rotary speed sensing
- Close loop stepper system
- Stepper encoder



TSSOP16

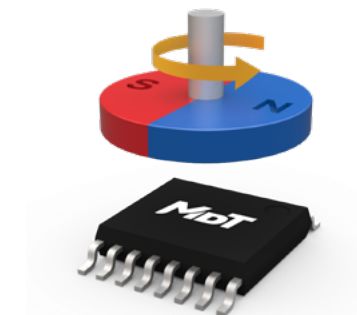

Selection Guide

Part Number (*)	Output Interface	Supply Voltage	Operating Temperature	Package	Packing Form
TMR3108P-01-4096	SPI/ABZ/UVW/PWM	3.3 V to 5 V	-40 °C to 125 °C	TSSOP16	Tape & Reel
TMR3108BP-04-2500	SPI/ABZ/UVW/PWM	5 V	-40 °C to 125 °C	TSSOP16	Tape & Reel
TMR3108CP-01-4096	SPI/ABZ/UVW/PWM	3.3 V to 5 V	-40 °C to 125 °C	TSSOP16	Tape & Reel

Note: * Please contact MDT local sales representative for more model's information.

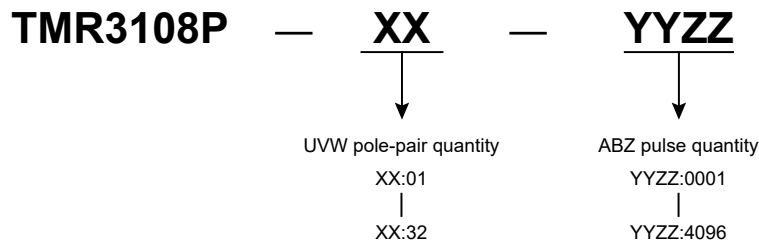

Catalogue

1. Pin Configuration	03
2. Functional Block Diagram	04
3. Absolute Maximum Ratings	05
4. Working condition	05
5. Electrical Specifications	05
6. Digital Input Signals	06
7. Digital Output Signals	06
8. PWM Characteristics	06
9. EEPROM Characteristics	06
10. Magnetic Field Specification	07
11. Output Mode	08
11.1 ABZ Output	08
11.2 UVW Output	09
11.3 PWM Output	09
11.4 SPI Output	10
12. Reference Circuits	12
13. Calibration	13
14. Mechanical Angle Orientation	14
15. Dimensions	15

1. Pin Configuration

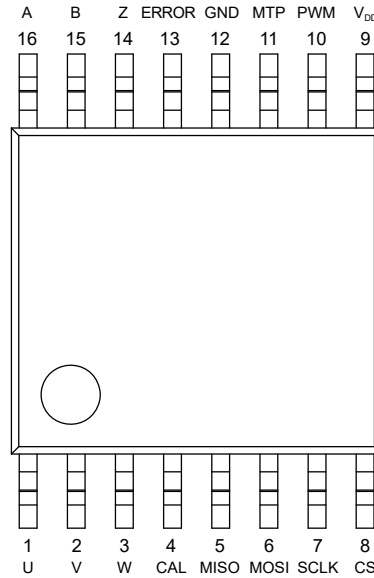

Figure 1. Pin configuration (TSSOP16)

Pin Number	Name	Input/Output	Signal type	Function
1	U	Output	Digital	U phase invert signal
2	V	Output	Digital	V phase invert signal
3	W	Output	Digital	W phase invert signal
4	CAL	Input	Digital	Auto calibration enabling signal (TMR3108P, TMR3108BP)
		Output	Digital	Auto calibration indication signal (TMR3108CP)
5	MISO	Output	Digital	SPI data out
6	MOSI	Input	Digital	SPI data in
7	SCLK	Input	Digital	SPI clock
8	CS	Input	Digital	SPI chip select
9	V _{DD}	Input	Power supply	Power supply
11	MTP	Input	Digital	EEPROM power supply (TMR3108P)
	NC	-	-	TMR3108BP, TMR3108CP
12	GND	Input	GND	GND
13	ERROR	Output	Digital	Error signal (TMR3108P)
	NC	-	-	TMR3108BP, TMR3108CP
14	Z	Output	Digital	Zero position pulse signal
15	B	Output	Digital	Phase B pulse signal
16	A	Output	Digital	Phase A pulse signal

2. Functional Block Diagram

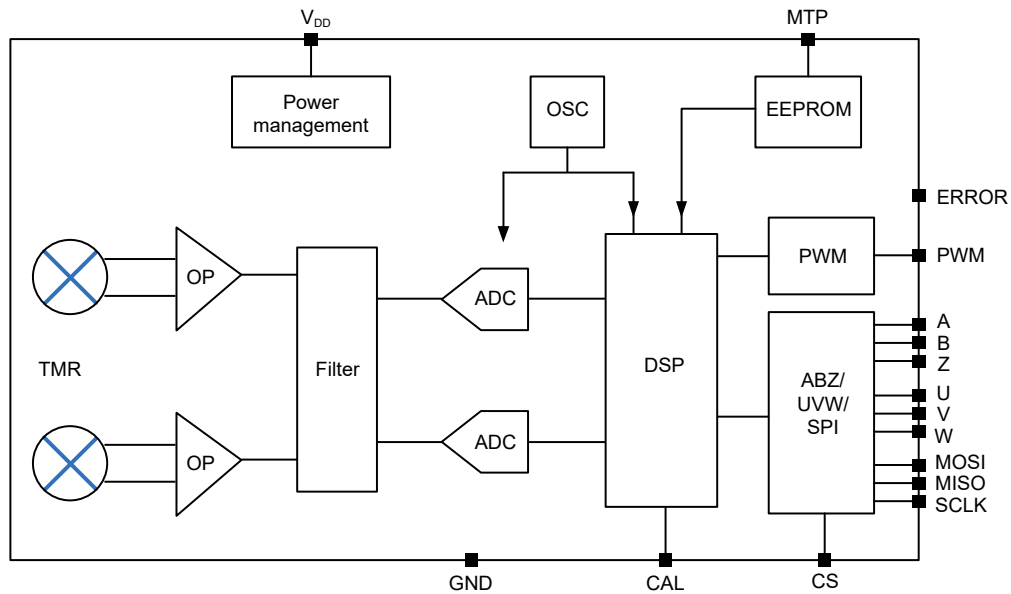

Figure 2. TMR3108 functional block diagram

Block	Function
TMR	TMR sensor element
OP	Amplifier
Filter	Filter
ADC	Analog-to-digital converter
DSP	Digital signal processing
POR	Power-on reset
Power management	Power management
ABZ/UVW/SPI	ABZ/UVW/SPI output interface
PWM	PWM output interface
OSC	Oscillator
EEPROM	Electrically erasable programmable read-only memory

3. Absolute Maximum Ratings

Parameter	Symbol	Min.	Max.	Unit
Supply voltage	V_{DD}	-0.3	6	V
Magnetic flux density	B	-	4000	Gs
A, B, Z, U, V, W, CS, SCLK, MISO, MOSI, CAL, ERROR pin input voltage	V_{IN1}	-0.3	V_{DD}	V
A, B, Z, U, V, W, MISO, ERROR pin output current	I_{OUT1}	-20	20	mA
Storage ambient temperature	T_{STG}	-40	150	°C
ESD performance (HBM)	V_{ESD}	-	4	kV

The Absolute Maximum Rating parameters is only a condition to ensure that the chip is not permanently damaged. For normal operating conditions, please refer to Electrical Specifications.

4. Working condition

Parameter	Symbol	Min.	Typ.	Max.	Unit	Applicable part number
Supply voltage	V_{DD}	3.3	5.0	5.5	V	TMR3108P TMR3108CP
		4.5	5.0	5.5	V	TMR3108BP
Operating ambient temperature	T_A	-40	-	125	°C	All parts
Rotation speed	R_{speed}	-	-	40000	RPM	All parts

5. Electrical Specifications

$T_A = -40\text{ °C to }125\text{ °C}$, $V_{DD} = 3.3\text{ V to }5.5\text{ V}$

Parameter	Symbol	Condition	Min.	Typ.	Max.	Unit
Measurement range	A_{range}	-	0	-	360	Deg
Absolute resolution	RES_{SDC}	-	-	17	-	bit
Nonlinearity error	INL_{OPT}	27 °C	-	-	±0.2	Deg
Nonlinearity error in full temperature range	INL_{drift}	-40 °C to 125 °C	-	-	±1	Deg
Differential nonlinearity	DNL	-	-	-	±0.08	Deg
Hysteresis	HYS	-	-	-	±0.1	Deg
Repeatability	A_{repeat}	-	-	-	±0.04	Deg
Output delay	T_D	-	-	2	-	µs
Supply current	I_{DD}	-	-	10	-	mA

6. Digital Input Signals

CS, SCLK, MOSI, CAL

Parameter	Symbol	Condition	Min.	Typ.	Max.	Unit
Input threshold high	$V_{I(HI)}$	-	$0.8 V_{DD}$	-	-	V
Input threshold low	$V_{I(LO)}$	-	-	-	$0.2 V_{DD}$	V

7. Digital Output Signals

A, B, Z, U, V, W, MISO, ERROR, PWM

Parameter	Symbol	Condition	Min.	Typ.	Max.	Unit
Output threshold high	$V_{O(HI)}$	$I = 1 \text{ mA}$	$V_{DD} - 0.3$	-	-	V
Output threshold low	$V_{O(LO)}$	$I = 1 \text{ mA}$	-	-	0.3	V
Rise time	t_{rise}	$C_L = 100 \text{ pF}$	-	-	100	ns
Fall time	t_{fall}	$C_L = 100 \text{ pF}$	-	-	100	ns
Output load capacitance	C_L	-	-	-	100	pF

8. PWM Characteristics

Parameter	Symbol	Condition	Min.	Typ.	Max.	Unit
PWM frequency	F_{PWM}	-	-	900 ¹⁾	-	Hz
Rise time	t_{rise}	$C_L = 10 \text{ nF}$	-	-	1	μs
Fall time	t_{fall}	$C_L = 10 \text{ nF}$	-	-	1	μs

Note:

- 1) End user may program PWM frequency

9. EEPROM Characteristics

Parameter	Symbol	Condition	Min.	Typ.	Max.	Unit
MTP read/write supply voltage ^{2), 3)}	V_{MTPW}	-	-	5	-	V
EEPROM read/write cycles	E_{EN}	-	10000	-	-	Cycle
Data storage time	E_{RE}	-	10	-	-	Year

Note:

- 2) For TMR3108P: When $V_{DD} = 3.3 \text{ V}$, MTP pin needs to be powered by 5V. When $V_{DD} = 5 \text{ V}$, the MTP pin can be left floating.
- 3) For TMR3108BP and TMR3108CP: Power V_{DD} and leave pin 11 floating to write data to EEPROM.

10. Magnetic Field Specification

Recommended magnet: cylindrical SmCo magnet (N35SH), $\phi 9$ mm \times 2.5 mm, radial magnetization

Parameter	Symbol	Condition	Min.	Typ.	Max.	Unit
Diameter of magnet	d_{mag}	-	6	9	20	mm
Thickness of magnet	t_{mag}	-	-	2.5	-	mm
Mounting distance	D_{in}	Recommend magnet ($\phi 9$ mm)	1	3	10	mm
Magnetic field	H_{ext}	Sensor surface	100	-	1000	Gs
Center deviation between magnet and sensor	X_{dis}	-	-	-	0.5	mm
Angle deviation of the sensor within package	Φ_{pac}	-	-3	-	3	Deg

11. Output Mode

11.1 ABZ Output

TMR3108P provides the incremental digital ABZ output through the A/B/Z pins. The A/B signals output interpolation factors can be programmed from 1 to 4096 pulses. Phase B precedes phase A when the magnet rotates counter-clockwise under the default settings as shown in Figure 3.

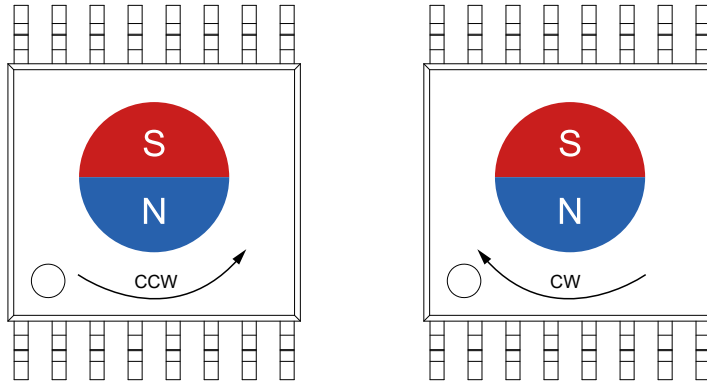

Figure 3. ABZ operating schematic

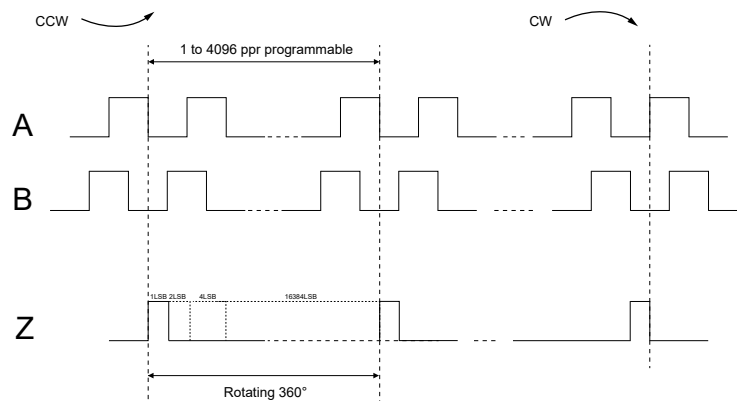

Figure 4. ABZ signal timing diagram

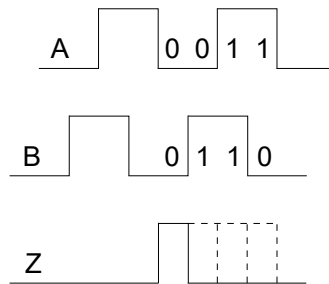

Figure 5. Z pulse initial position diagram

As shown in Fig 4 and Fig 5, the phase Z width is programmable from 1 to 16384 LSB. The initial Z pulse position aligns where phase A and phase B are 0, and this Z phase alignment position can be programmed by the customer to any LSB position within one cycle of the A and B phases.

The xMR310x calibration kit and corresponding host computer software is provided for the convenience of customer calibration and settings. The parameters settings for the zero position (phase Z), width of phase Z, hysteresis parameters, PPR parameters, and CW/CCW setup of TMR3108 sensor can be performed by this xMR310x calibration kit.

11.2 UVW Output

TMR3108P provides UVW commutation output signals with a phase difference of 1/3 cycle between each other for detecting brushless DC motors. TMR3108P is available in UVW mode through output mode setting, and the pole-pair quantity is programmable in 1 to 32 as shown in Figure 6.

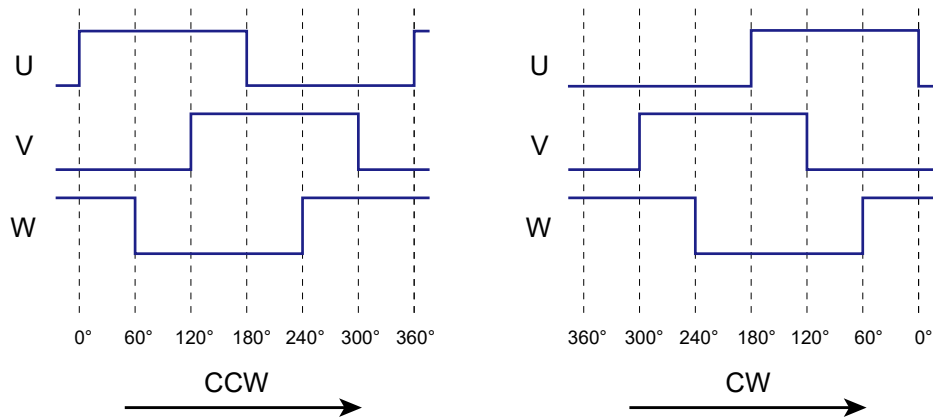

Figure 6. UVW output diagram

The xMR310x calibration kit and corresponding host computer software is provided for the convenience of customer calibration and settings. The parameters settings for the zero position (phase U), hysteresis parameters, UVW pole-pair quantity of TMR3108 sensor can be set by this xMR310x calibration kit.

11.3 PWM Output

TMR3108P supports pulse width modulation (PWM) output. The duty cycle of PWM is a logic signal proportional to the magnetic field angle. Figure 7 shows one period of the PWM signal, and the period (T) is 1/FPWM. This period consists of 4119 minimum clock periods, starting from fixed 16 clock periods of high voltage and ending with 8 clock periods of low voltage. The total period (T) in between contains 4095 clock periods with a resolution of 12-bits. The minimum clock period is user programmable.

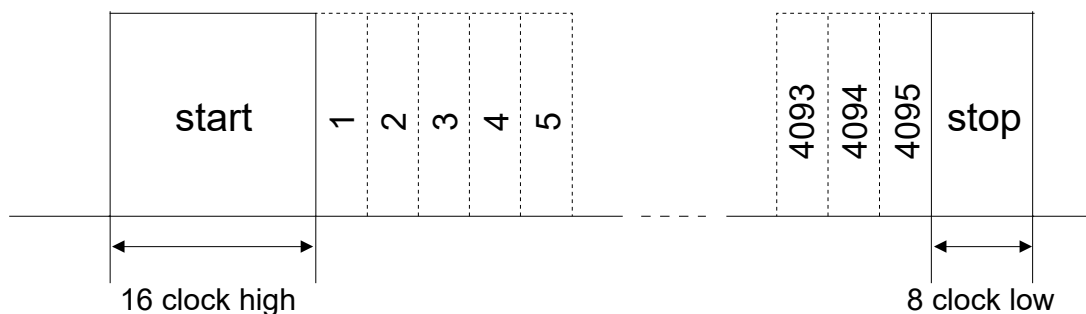

Figure 7. PWM output signal

The xMR310x calibration kit and corresponding host computer software is provided for the convenience of customer calibration and settings. The PWM pulse width and frequency of TMR3108 sensor can be set by this xMR310x calibration kit.

11.4 SPI Output

TMR3108P provides the 4-wire SPI interface for user programming in common mode 1 (CPOL=0, CPHA=1). Data communication is only enabled when the CS pin is set to LOW. The MOSI pin carries the serial input data that will be written to the IC upon the falling edge of the SCLK signal. The serial output data is available to read at the MISO pin upon the rising edge of the SCLK signal.

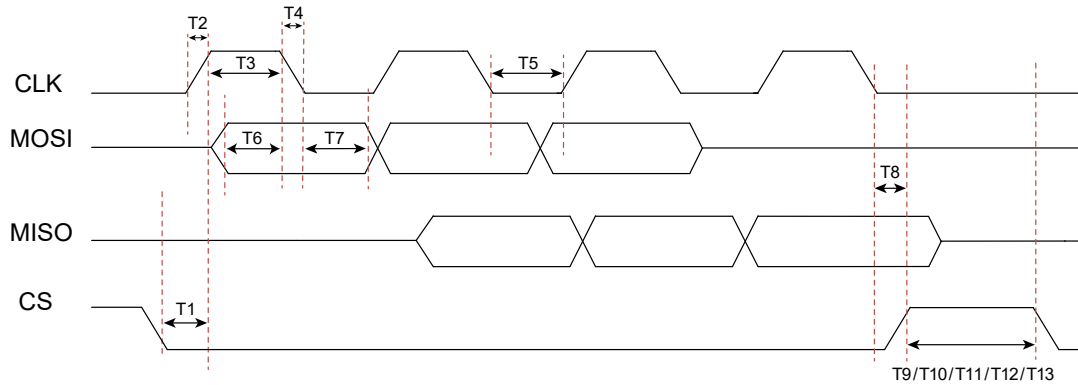

Figure 8. SPI timing diagram

Signal	Definition	Min.	Typ.	Max.	Unit
T1	SPI start-up time	-	100	-	ns
T2/T4	Clock signal rising/falling time	10	-	-	ns
T3	Clock signal HIGH period	40	-	-	ns
T5	Clock signal LOW period	40	-	-	ns
T6	Input signal setup time	30	-	-	ns
T7	Input signal sampling hold time	30	-	-	ns
T8	SPI closing time	-	50	-	ns
T9	SPI reading interval	1	-	-	μs
T10	EEPROM input interval	300	-	-	ms
T11	Time interval between writing register, reading register, and reading EEPROM	2.5	-	-	μs
T12	Mode switching interval (normal to user mode)	5	-	-	ms
T13	Mode switching interval user to normal mode)	40	-	-	ms

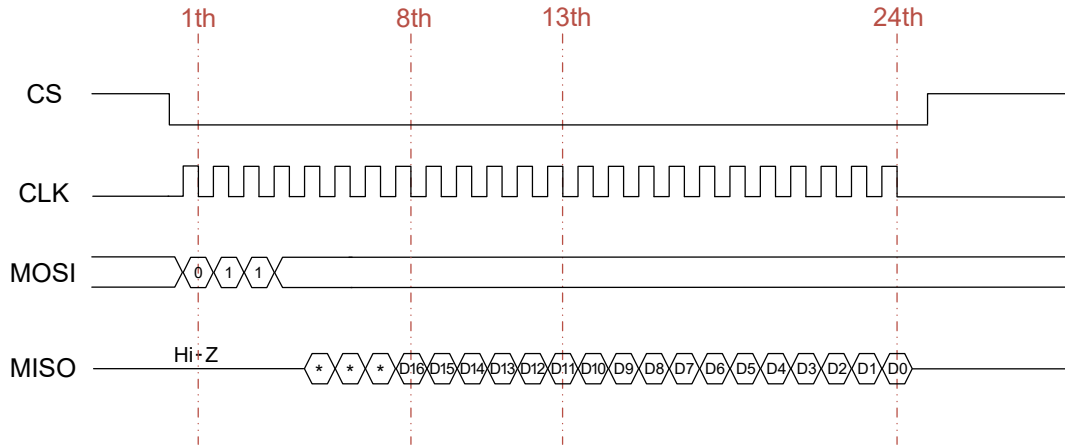

Figure 9. SPI angle timing diagram

D[16:0]: 17-bit angle data

Absolute angle θ in the range of 0 to 360° can be calculated using the following formula:

$$\theta = \frac{\sum_{i=0}^{16} 2^{D[i]}}{131072} \times 360^\circ$$

12. Reference Circuits

An external 100 nF decoupling capacitor is recommended between the power supply and ground. TMR3108P can be configured to use either a 4-wire or 3-wire SPI interface, as shown in Figure 10 and Figure 11. When configured for 3-wire SPI, MISO and MOSI are connected and can serve as input or output.

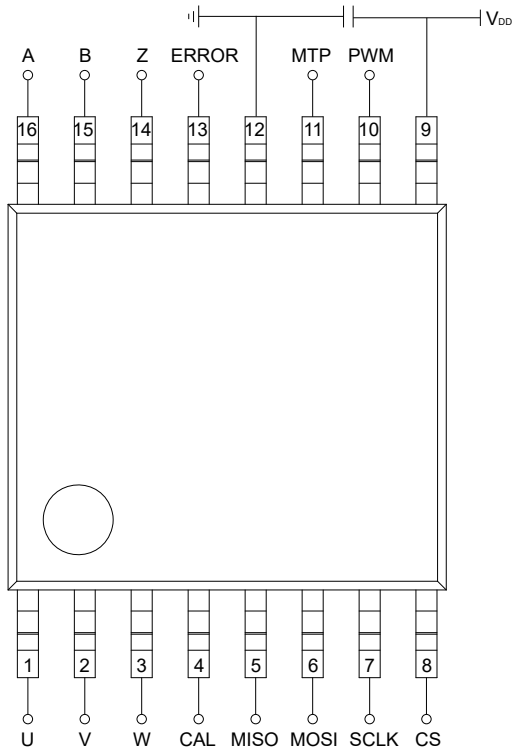

Figure 10. 4-wire SPI reference circuit

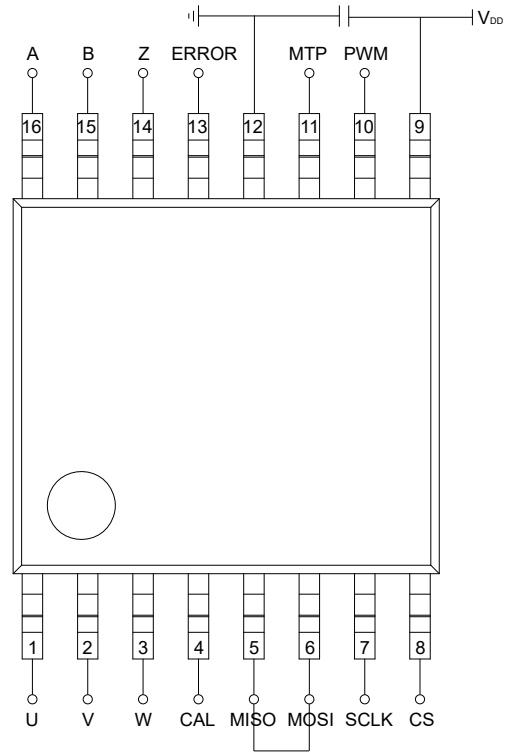

Figure 11. 3-wire SPI reference circuit

13. Calibration

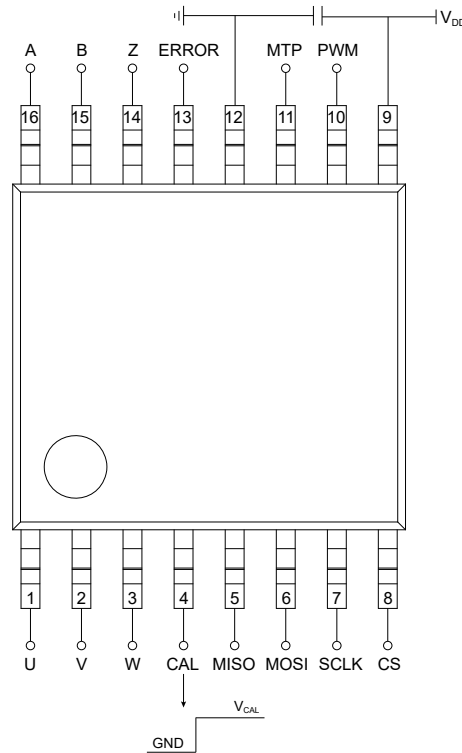

Figure 12. Self-calibration schematic

The TMR3108 provides a self-calibration function to adapt to user-specific magnetic fields or installation conditions. The feature is accessible when the sensor is setup as shown in Figure 13. The magnet needs to be rotating in counter-clockwise direction at a constant speed between 300 RPM to 3000 RPM. 600 RPM is recommended.

To calibrate the TMR3108P/TMR3108BP, first rotate the motor or system at a constant speed, then connect the CAL pin to VDD as shown in Figure 12. Calibration will complete after 30+ revolutions.

For the TMR3108CP, please contact the MultiDimension Technology team to request calibration command or “xMR310x Demo Board”. To calibrate the TMR3108CP, first input the calibration command before initiating self-calibration. Calibration is complete once CAL pin outputs low voltage.

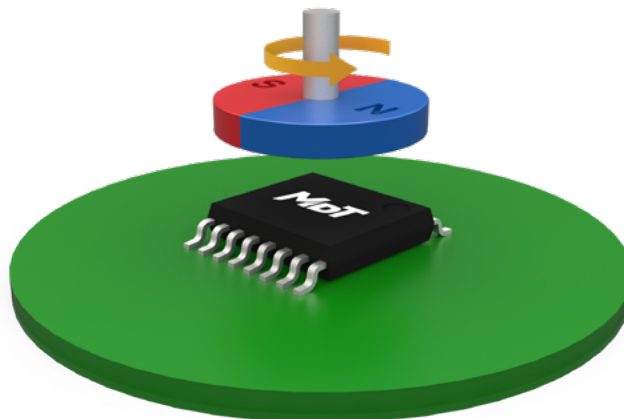

Figure 13. Self-calibration schematic

14. Mechanical Angle Orientation

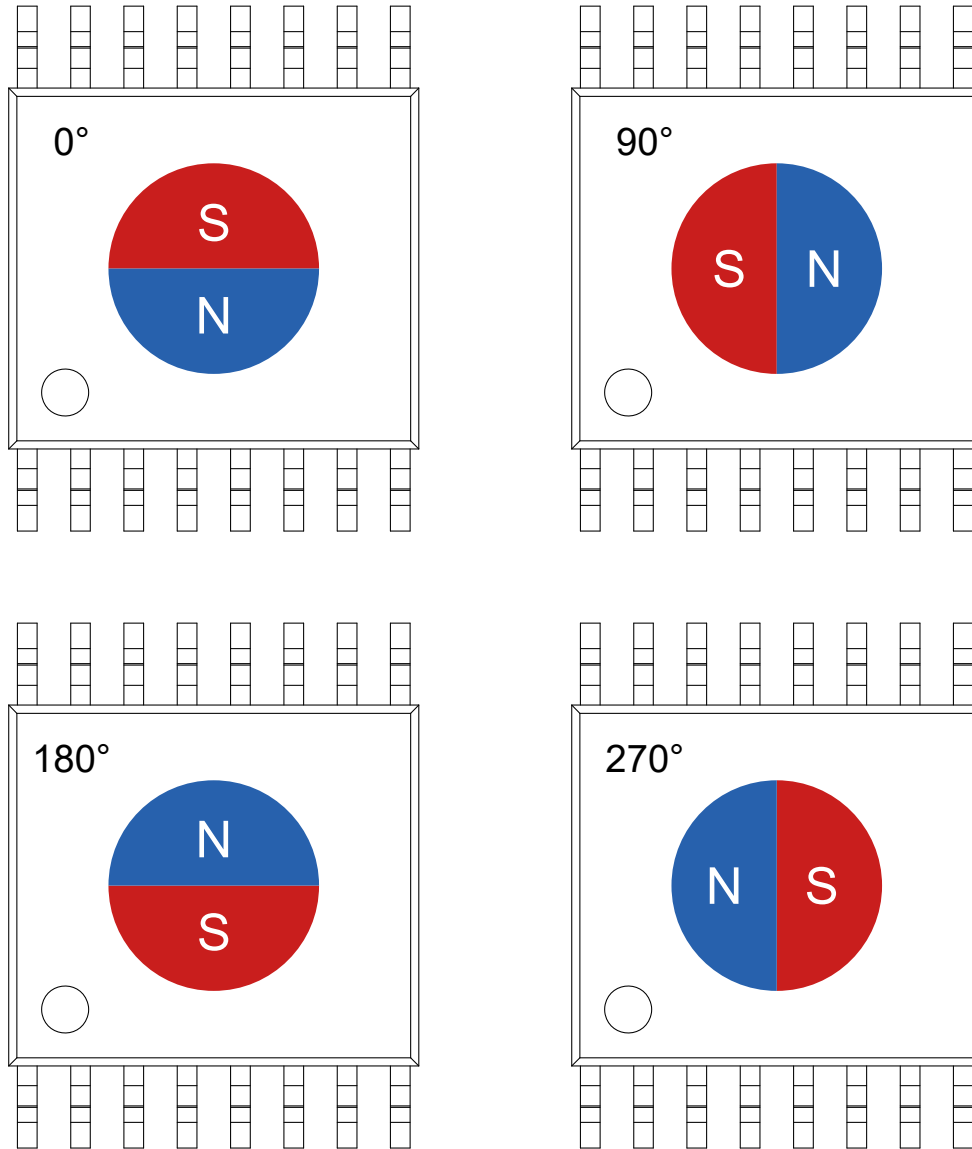

Figure 14. Definition of the magnetic field orientation measured by TMR3108P

15. Dimensions

TSSOP16 Package

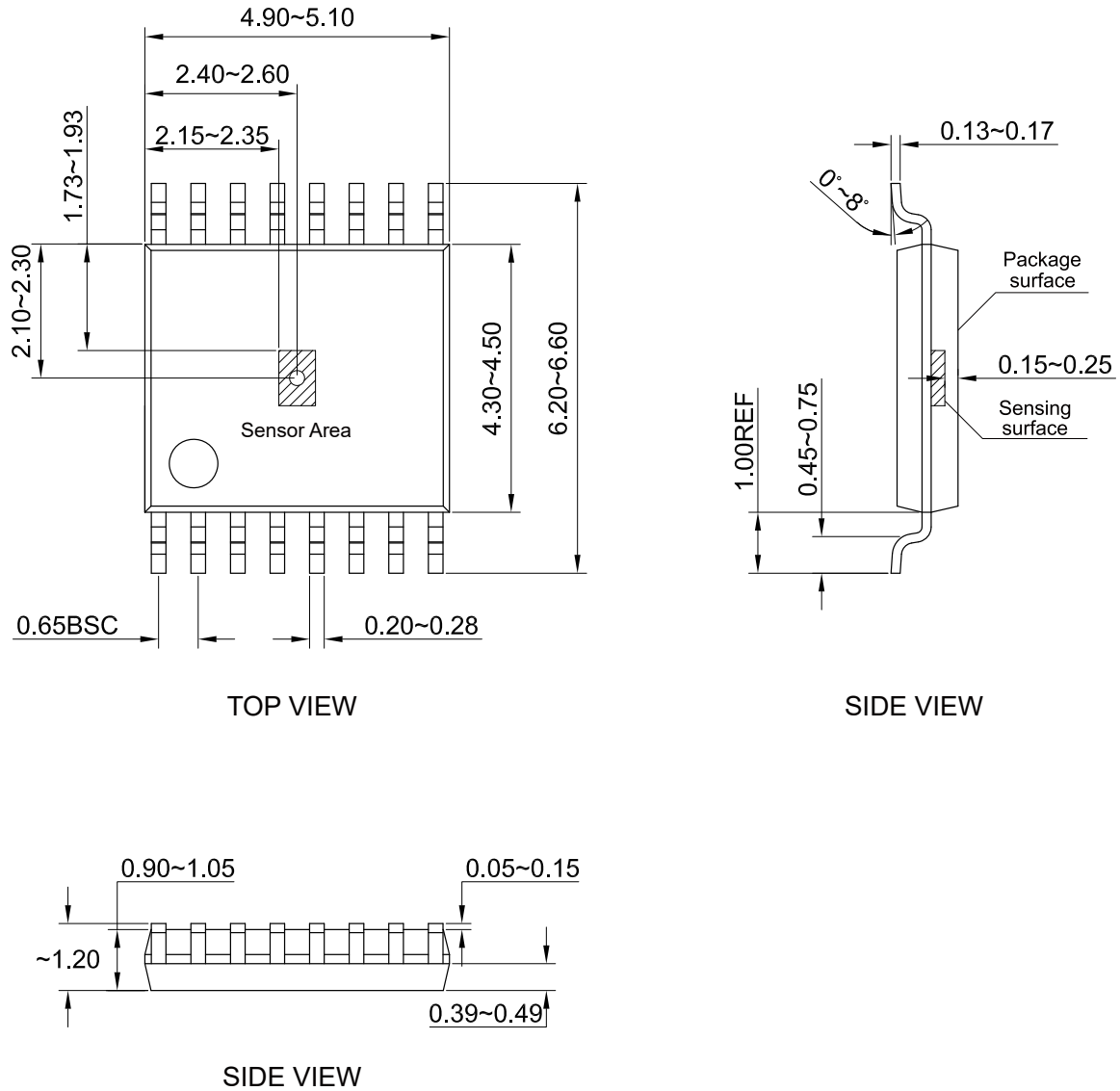

Figure 15. Package outline of TSSOP16 (unit: mm)

Copyright © 2023 by MultiDimension Technology Co., Ltd.

Information furnished herein by MultiDimension Technology Co., Ltd. (hereinafter MDT) is believed to be accurate and reliable. However, MDT disclaims any and all warranties and liabilities of any kind, with respect to any examples, hints or any performance or use of technical data as described herein and/or any information regarding the application of the product, including without limitation warranties of non-infringement of intellectual property rights of any third party. This document neither conveys nor implies any license under patent or other industrial or intellectual property rights. Customer or any third-party must further determine the suitability of the MDT products for its applications to avoid the applications default of customer or third-party. MDT accept no liability in this respect.

MDT does not assume any liabilities of any indirect, incidental, punitive, special or consequential damages (including without limitation of lost profits, lost savings, business interruption, costs related to the removal or replacement of any products or rework charges) whether or not such damages are based on tort (including negligence), warranty, breach of contract or any other legal theory. Notwithstanding any damages that customer might incur for any reason whatsoever, MDT's aggregate and cumulative liability towards customer for the products described herein shall be limited in accordance with the terms and conditions of commercial sale of MDT.

Absolute maximum ratings are the extreme limits the device will withstand without damage to the MDT product. However, the electrical and mechanical characteristics are not guaranteed as the maximum limits (above recommended operating conditions) are approached. MDT disclaims any and all warranties and liabilities of the MDT product will operate at absolute maximum ratings.

Specifications may change without notice.

Please download latest document from our official website www.dowaytech.com/en.

Recycling

The product(s) in this document need to be handed over to a qualified solid waste management services company for recycling in accordance with relevant regulations on waste classification after the end of the product(s) life.



No.2 Guangdong Road, Zhangjiagang Free Trade Zone, Jiangsu, China

Web: www.dowaytech.com/en E-mail: info@dowaytech.com

