

BASE AND CASE

High-resistance polyamide based (PA) technopolymer.
Black base.

Case in the following colours:

- **C2**: RAL 2004 orange, glossy finish.
- **C3**: RAL 7035 grey, glossy finish.
- **C1**: RAL 7021 grey-black, glossy finish.

The ultrasonic welding between the base and the case prevents separation and avoids dust penetration.

WINDOW

Transparent polyamide based (PA-T) technopolymer, moulded over the case and with a perfect seal. Resistant to solvents, oils, greases and other chemical agents (avoid contact with alcohol during cleaning operations).

DISPLAY

It indicates the displacement of the mechanism controlled by the spindle from the start position (0).

Five-digit roller counter (four black rolls and one red roll or three black rolls and two red rolls). The digits of red rolls show the decimal values. An additional graduated scale next to the last decimal digit offers further accuracy of reading.

The display can be in different positions (see "Table of the possible combinations").

- **AN**: inclined display, counter in upper position.
- **AR**: inclined display, counter in lower position.
- **FN**: front display, counter in upper position.
- **FR**: front display, counter in lower position.

INTERNAL GASKET

O-ring front sealing in NBR synthetic rubber, between the case and the boss.

REAR GASKET

Foam polyethylene, supplied.

STANDARD EXECUTIONS

Boss with $\varnothing 20$ mm H7 reamed hole, fitting to shaft by means of a grub screw with hexagon socket and cup end, included in the supply.

- **DD52R**: black-oxide steel boss.
- **DD52R-SST**: INOX AISI 303 stainless steel boss.

DIRECTION OF ROTATION

- **D**: clockwise. Increasing values with clockwise rotation of the boss.
- **S**: anti-clockwise. Increasing values with anti-clockwise rotation of the boss.

WEIGHT

97 grams.

FEATURES AND APPLICATIONS

Direct drive digital position indicators can be assembled on passing through spindles in any position to give direct reading of the positioning of a machine component. They are suitable also for motor driven applications (see "Table of the possible combinations").

ERGONOMY AND DESIGN

Compact roller counter, ergonomically designed digits for rapid reading. The readability of the counter is increased by the magnifying window.

ASSEMBLY INSTRUCTIONS







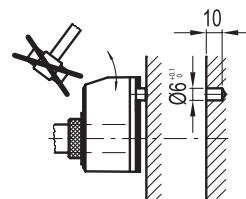
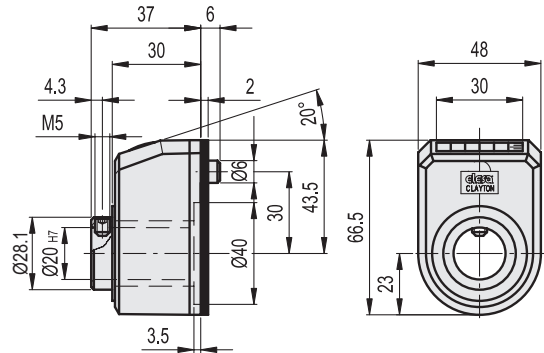



1. Drill a $\varnothing 6$ mm by 10 mm hole in the body of the machine with a 30 mm centre distance from the spindle to fit the rear referring pin.
2. Set the spindle to the start or referring position.
3. Fit the indicator with the zeroed roller counter onto the spindle and make sure that the referring pin fit the hole.
4. Clamp the boss to the spindle by tightening the grub screw with hexagon socket and cup end, according to UNI 5929-85.



ELESA Original design



Example of description for ordering

| | | | | | | | | | | |
|---|----------|---|----------|--|----------|--|----------|--|----------|--|
| DD52R | - | AN | - | 00001 | - | D | - | C2 | - | SST |
| Series | | Display position | | Reading of the counter after one revolution | | Increasing numbering | | Colour | | Stainless steel boss |
|  AN | |  AR | | The internal mechanism counts also the figures between brackets (even if they do not appear on the display). | |  D clockwise | |  C2 RAL 2004 | |  To add only for the version with stainless steel boss |
|  FN | |  FR | | | |  S anti-clockwise | |  C3 RAL 7035 | | |
| | | | | | | | |  C1 RAL 7021 | | |

| 0 0 0 0 1 | 0 0 0 0 1 | 0 0 0 0 1 | 0 0 0 0 1 | Pitch | Speed (rpm) * |
|-------------|--------------|--------------|--------------|---------|---------------|
| 00001 | 0000.1 | 000.01 | 00.001 | 0.1 | 1500 |
| 00004 | 0000.4 | 000.04 | 00.004 | 0.4 | 1500 |
| 00005 | 0000.5 | 000.05 | 00.005 | 0.5 | 1500 |
| 00009(6) | 0000.9(6) | 000.09(6) | 00.009(6) | 0.96 | 1500 |
| 00010 | 0001.0 | 000.10 | 00.010 | 1.0 | 1500 |
| 00012(5) | 0001.2(5) | 000.12(5) | 00.012(5) | 1.25 | 1500 |
| 00015 | 0001.5 | 000.15 | 00.015 | 1.5 | 1500 |
| 00015(8) | 0001.5(8) | 000.15(8) | 00.015(8) | 1.58 | 1500 |
| 00015(75) | 0001.5(75) | 000.15(75) | 00.015(75) | 1.575 | 1500 |
| 00016(07) | 0001.6(07) | 000.16(07) | 00.016(07) | 1.607 | 1500 |
| 00017(5) | 0001.7(5) | 000.17(5) | 00.017(5) | 1.75 | 1420 |
| 00019(6875) | 0001.9(6875) | 000.19(6875) | 00.019(6875) | 1.96875 | 1270 |
| 00020 | 0002.0 | 000.20 | 00.020 | 2.0 | 1250 |
| 00025 | 0002.5 | 000.25 | 00.025 | 2.5 | 1000 |
| 00025(4) | 0002.5(4) | 000.25(4) | 00.025(4) | 2.54 | 980 |
| 00030 | 0003.0 | 000.30 | 00.030 | 3.0 | 830 |
| 00031(5) | 0003.1(5) | 000.31(5) | 00.031(5) | 3.15 | 790 |
| 00031(75) | 0003.1(75) | 000.31(75) | 00.031(75) | 3.175 | 780 |
| 00035 | 0003.5 | 000.35 | 00.035 | 3.5 | 710 |
| 00038(095) | 0003.8(095) | 000.38(095) | 00.038(095) | 3.8095 | 650 |
| 00039(375) | 0003.9(375) | 000.39(375) | 00.039(375) | 3.9375 | 640 |
| 00040 | 0004.0 | 000.40 | 00.040 | 4.0 | 625 |
| 00042(9) | 0004.2(9) | 000.42(9) | 00.042(9) | 4.29 | 580 |
| 00050 | 0005.0 | 000.50 | 00.050 | 5.0 | 500 |
| 00050(8) | 0005.0(8) | 000.50(8) | 00.050(8) | 5.08 | 490 |
| 00052(94) | 0005.2(94) | 000.52(94) | 00.052(94) | 5.294 | 470 |
| 00056(47) | 0005.6(47) | 000.56(47) | 00.056(47) | 5.647 | 440 |
| 00060 | 0006.0 | 000.60 | 00.060 | 6.0 | 415 |
| 00062(5) | 0006.2(5) | 000.62(5) | 00.062(5) | 6.25 | 400 |
| 00063(5) | 0006.3(5) | 000.63(5) | 00.063(5) | 6.35 | 390 |
| 00066 | 0006.6 | 000.66 | 00.066 | 6.6 | 370 |
| 00070 | 0007.0 | 000.70 | 00.070 | 7.0 | 350 |
| 00075 | 0007.5 | 000.75 | 00.075 | 7.5 | 330 |
| 00076(923) | 0007.6(923) | 000.76(923) | 00.076(923) | 7.6923 | 325 |
| 00078(75) | 0007.8(75) | 00078(75) | 00.078(75) | 7.875 | 310 |
| 00080 | 0008.0 | 000.80 | 00.080 | 8.0 | 315 |
| 00090 | 0009.0 | 000.90 | 00.090 | 9.0 | 270 |
| 00100 | 0010.0 | 001.00 | 00.100 | 10.0 | 250 |
| 00105 | 0010.5 | 001.05 | 00.105 | 10.5 | 235 |
| 00118(125) | 0011.8(125) | 001.18(125) | 00.118(125) | 11.8125 | 205 |
| 00119(05) | 0011.9(05) | 001.19(05) | 00.119(05) | 11.905 | 210 |
| 00120 | 0012.0 | 001.20 | 00.120 | 12.0 | 200 |
| 00130 | 0013.0 | 001.30 | 00.130 | 13.0 | 190 |
| 00150 | 0015.0 | 001.50 | 00.150 | 15.0 | 160 |
| 00160 | 0016.0 | 001.60 | 00.160 | 16.0 | 150 |
| 00200 | 0020.0 | 002.00 | 00.200 | 20.0 | 125 |

*The maximum rotation speed (rpm) of the spindle reported in the table corresponds to a maximum rotation of 25000 units of the last roll on the right of the counter.

Rotational speed tests have been performed in our laboratory under standard operating conditions. Small misalignments (not compromising the correct reading) of counter digits can occur due to high tolerances between gear teeth, designed to prevent damage from sudden acceleration or stop.

SPECIAL EXECUTIONS ON REQUEST

- Special readings after one revolution.
- Case in different colours.
- Completely sealed digital position indicators with IP 67 protection class, see table EN 60529 (on page A-19) obtained by means of a brass bushing with double seal ring inside the rear cavity of the base.

ACCESSORIES ON REQUEST (TO BE ORDERED SEPARATELY)

- **MDX-52:** polyamide based (PA) technopolymer knob.
- **BSA-N52:** zinc die-cast bases for spindle locking, epoxy resin coating, black colour, matte finish (see table). Type GN 302.1 adjustable handle. BSA-N52 locking bases allow an easy and quick locking of the spindles after their positioning. They are equipped with a \varnothing 6.1 mm hole to fit the referring pin of the indicator. They can be assembled with the handle either on the right or on the left and can be fitted to the machine by means of two M5 cylindrical-head screws (not included in the supply).

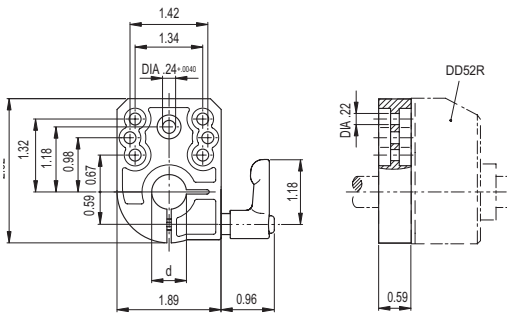

METRIC

| Code | Description | dH7 | |
|----------|-------------|-----|-----|
| CE.87921 | BSA-N52-12 | 12 | 193 |
| CE.87923 | BSA-N52-14 | 14 | 189 |
| CE.87924 | BSA-N52-15 | 15 | 187 |
| CE.87925 | BSA-N52-16 | 16 | 185 |
| CE.87929 | BSA-N52-20 | 20 | 175 |

- **RB52:** black-oxide steel reduction sleeves.
- **RB52-SST:** AISI 304 stainless steel reduction sleeves.

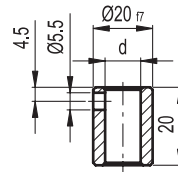

RB52

METRIC

| Code | Description | dH7 |
|----------|-------------|-----|
| CE.87940 | RB52-12 | 12 |
| CE.87950 | RB52-14 | 14 |
| CE.87955 | RB52-15 | 15 |
| CE.87960 | RB52-16 | 16 |

RB52-SST

INOX STAINLESS STEEL METRIC

| Code | Description | dH7 |
|----------|-----------------|-----|
| CE.97941 | RB52-12-SST-304 | 12 |
| CE.97951 | RB52-14-SST-304 | 14 |
| CE.97956 | RB52-15-SST-304 | 15 |
| CE.97961 | RB52-16-SST-304 | 16 |

- **PE.6-10:** red technopolymer pin (code CE.83960).

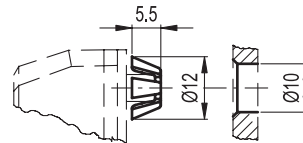

- **BS52R:** glass-fibre reinforced polyamide based (PA) technopolymer spacer base (code CE.83950), designed with two pre-drilled holes for UNI 10227 self-tapping screws \varnothing 2.2 (not included in the supply).

