

Data sheet | Item number: 828-334

Feedthrough terminal block; lever; Plate thickness: 3 mm; 16 mm²; Pin spacing 11.5 mm; 4-pole; CAGE CLAMP®; 16,00 mm²; gray

www.wago.com/828-334

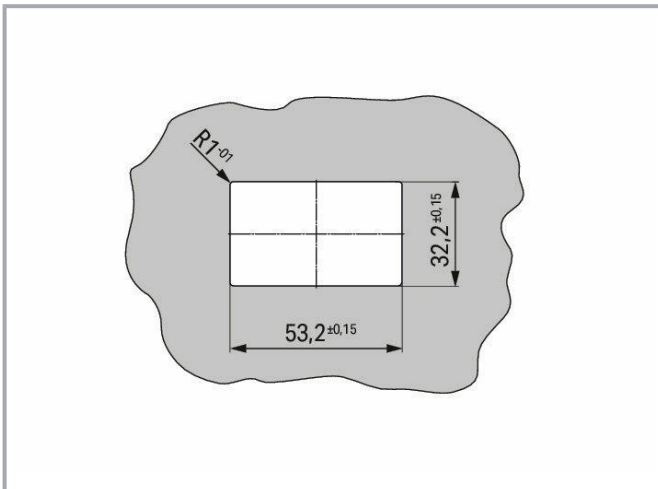
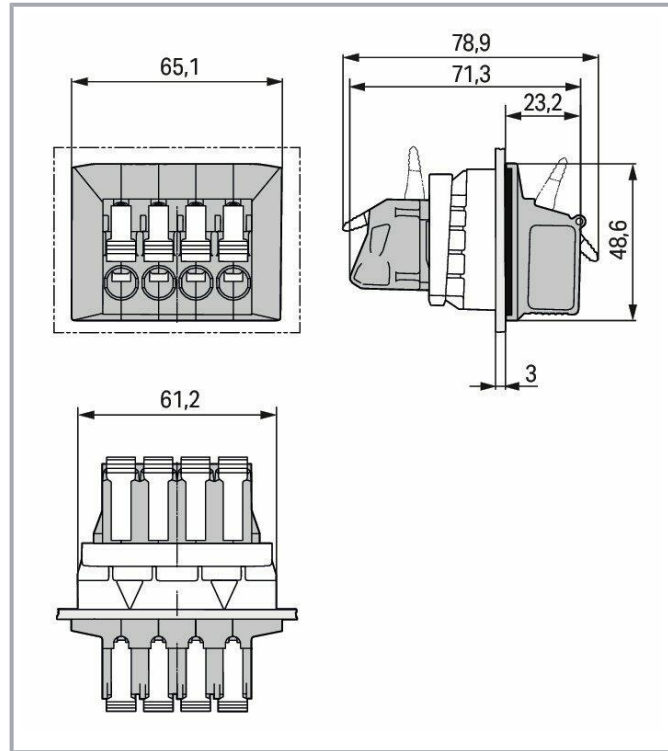
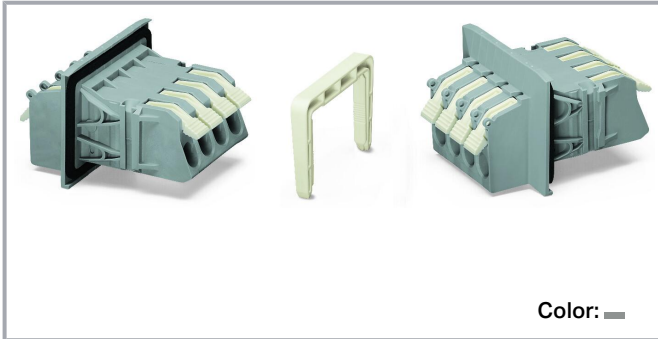

Subject to changes. Please also observe the further product documentation!

WAGO GmbH & Co. KG
Hansastr. 27
32423 Minden
Phone: +49571 887-0 | Fax: +49571 887-169
Email: info.de@wago.com | Web: www.wago.com

Do you have any questions about our products?
We are always happy to take your call at +49 (571) 887-44222.



Item description

- Feedthrough terminal strips with CAGE CLAMP® on both sides
- Easy, tool-free installation
- Tool-free termination – fingers open/close levers
- Several clamping units can be held open simultaneously – convenient for terminating multi-core cables
- 600 V UL

Data

Notes

Variants:

Other pole numbers

Adapters for varying sheet panel thicknesses

Direct marking

Other versions (or variants) can be requested from WAGO Sales or configured at <https://configurator.wago.com/>.

Electrical data

Ratings per IEC/EN

Ratings per	IEC/EN 60664-1
Nominal voltage (III/3)	1000 V
Rated impulse voltage (III/3)	8 kV
Rated voltage (III/2)	1000 V
Rated impulse voltage (III/2)	8 kV
Nominal voltage (II/2)	1000 V
Rated surge voltage (II/2)	8 kV
Rated current	57 A
Legend (ratings)	(III / 2) \triangleq Overvoltage category III / Pollution degree 2

Ratings per UL

Approvals per	UL 1059
Rated voltage UL (Use Group B)	600 V
Rated current UL (Use Group B)	30 A
Rated voltage UL (Use Group C)	600 V
Rated current UL (Use Group C)	30 A

Subject to changes. Please also observe the further product documentation!

WAGO GmbH & Co. KG

Hansastr. 27

32423 Minden

Phone: +49571 887-0 | Fax: +49571 887-169

Email: info.de@wago.com | Web: www.wago.com

Do you have any questions about our products?

We are always happy to take your call at +49 (571) 887-44222.

Ratings per CSA

Approvals per	CSA
Rated voltage CSA (Use Group B)	600 V
Rated current CSA (Use Group B)	30 A
Rated voltage CSA (Use Group C)	600 V
Rated current CSA (Use Group C)	30 A

Connection data

Connection points	8
Total number of potentials	4
Number of connection types	2
Number of levels	1

Connection 1

Connection technology	CAGE CLAMP®
Actuation type	Lever
Solid conductor	1.5 ... 16 mm ² / 16 ... 6 AWG
Fine-stranded conductor	1.5 ... 16 mm ² / 16 ... 6 AWG
Fine-stranded conductor; with insulated ferrule	1.5 ... 10 mm ²
Fine-stranded conductor; with uninsulated ferrule	1.5 ... 10 mm ²
Strip length	12 ... 13 mm / 0.47 ... 0.51 inches
Pole number	4

Physical data

Pin spacing	11.5 mm / 0.453 inches
Width	65.1 mm / 2.563 inches
Height	48.6 mm / 1.913 inches
Depth	78.9 mm / 3.106 inches

Mechanical data

Housing sheet thickness	3 ... 3 mm / 0.118 ... 0.118 inches
Mounting type	Locking claw
Mounting type	Feed-through mounting

Subject to changes. Please also observe the further product documentation!

Material data

Note (material data)

Information on material specifications can be found here

Color	gray
Material group	I
Insulation material	Polyamide (PA66)
Flammability class per UL94	V0
Clamping spring material	Chrome-nickel spring steel (CrNi)
Contact material	Electrolytic copper (E _{Cu})
Contact plating	Tin
Fire load	2.744 MJ
Weight	121.5 g

Environmental requirements

Limit temperature range	-60 ... +105 °C
Processing temperature	-35 ... +60 °C

Commercial data

Product Group	4 (Printed Circuit Connectors)
eCl@ss 10.0	27-14-11-34
eCl@ss 9.0	27-14-11-34
ETIM 8.0	EC001283
ETIM 7.0	EC001283
ECCN	NO DATA
PU (SPU)	15 pcs
Packaging type	bag
Country of origin	CN
GTIN	4050821148777
Customs tariff number	85369010000

Environmental Product Compliance

REACH Candidate List Substance	Perfluorobutane sulfonic acid (PFBS) and its salts
RoHS Compliance Status	Compliant, No Exemption
SCIP notification number (Austria)	0d734595-b959-4481-9e24-30848b1e4c59

Subject to changes. Please also observe the further product documentation!





WAGO GmbH & Co. KG
 Hansastr. 27
 32423 Minden
 Phone: +49571 887-0 | Fax: +49571 887-169
 Email: info.de@wago.com | Web: www.wago.com

Do you have any questions about our products?
 We are always happy to take your call at +49 (571) 887-44222.

SCIP notification number (Belgium)	9541b29a-e66a-4057-8d23-5fc290967632
SCIP notification number (Bulgaria)	3734b5be-3528-42b4-8a5a-5dd03bb0cea1
SCIP notification number (Czech Republic)	55b8ed86-163e-4a8a-b21e-c45d10ae48d4
SCIP notification number (Denmark)	8d6b435d-e6df-4a1f-9f1a-4ed8f880bc26
SCIP notification number (Finland)	ee92680d-3320-41b2-950e-1552139d0615
SCIP notification number (France)	82d1ef36-b6a7-4ec7-a933-9ee44eff2a31
SCIP notification number (Germany)	53c0bf5c-8b50-4ab0-a882-e0acad435acd
SCIP notification number (Hungary)	75a68f21-0f78-446a-84a7-00b131e85d43
SCIP notification number (Italy)	bcff2cba-dc35-4397-ab96-91173936d8fa
SCIP notification number (Netherlands)	2c2b2543-7430-49d7-bd72-5293c711a5a6
SCIP notification number (Poland)	87b40070-b129-4cf7-9aab-3462de5f5d5c
SCIP notification number (Romania)	c0b2317f-ecc7-4117-8873-9a67a067a90c
SCIP notification number (Sweden)	e495909f-40dd-4a6f-be51-7ceb74fe1f28

Approvals / Certificates

General approvals

Logo	Approval	Additional Approval Text	Certificate name
	CCA DEKRA Certification B.V.	EN 60947	NTR NL-7760
	CCA DEKRA Certification B.V.	EN 60947	71-1082983
	CSA DEKRA Certification B.V.	C22.2 No. 158	2059958
	UL UL International Germany GmbH	UL 1059	E45172

Declarations of conformity and manufacturer's declarations

Logo	Approval	Additional Approval Text	Certificate name
	EU-Declaration of Conformity WAGO GmbH & Co. KG	-	-







Subject to changes. Please also observe the further product documentation!



UK-Declaration of Conformity
WAGO GmbH & Co. KG

Optional accessories









Ferrule

Ferrule		
	Item no.: 216-104 Ferrule; Sleeve for 1.5 mm ² / AWG 16; uninsulated; electro-tin plated; silver-colored	www.wago.com/216-104
	Item no.: 216-106 Ferrule; Sleeve for 2.5 mm ² / AWG 14; uninsulated; electro-tin plated; silver-colored	www.wago.com/216-106
	Item no.: 216-107 Ferrule; Sleeve for 4 mm ² / AWG 12; uninsulated; electro-tin plated	www.wago.com/216-107
	Item no.: 216-108 Ferrule; Sleeve for 6 mm ² / AWG 10; uninsulated; electro-tin plated; silver-colored	www.wago.com/216-108
	Item no.: 216-109 Ferrule; Sleeve for 10 mm ² / AWG 8; uninsulated; electro-tin plated	www.wago.com/216-109
	Item no.: 216-124 Ferrule; Sleeve for 1.5 mm ² / AWG 16; uninsulated; electro-tin plated	www.wago.com/216-124
	Item no.: 216-206 Ferrule; Sleeve for 2.5 mm ² / AWG 14; insulated; electro-tin plated; blue	www.wago.com/216-206
	Item no.: 216-207 Ferrule; Sleeve for 4 mm ² / AWG 12; insulated; electro-tin plated; gray	www.wago.com/216-207
	Item no.: 216-204 Ferrule; Sleeve for 1.5 mm ² / AWG 16; insulated; electro-tin plated; black	www.wago.com/216-204
	Item no.: 216-209 Ferrule; Sleeve for 10 mm ² / AWG 8; insulated; electro-tin plated; red	www.wago.com/216-209
	Item no.: 216-205 Ferrule; Sleeve for 2.08 mm ² / AWG 14; insulated; electro-tin plated; yellow	www.wago.com/216-205
	Item no.: 216-144 Ferrule; Sleeve for 1.5 mm ² / AWG 16; uninsulated; electro-tin plated; electrolytic copper; gastight crimped; acc. to DIN 46228, Part 1/08.92; silver-colored	www.wago.com/216-144
	Item no.: 216-208 Ferrule; Sleeve for 6 mm ² / AWG 10; insulated; electro-tin plated; electrolytic copper; gastight crimped; acc. to DIN 46228, Part 4/09.90; yellow	www.wago.com/216-208
	Item no.: 216-224 Ferrule; Sleeve for 1.5 mm ² / AWG 16; insulated; electro-tin plated; black	www.wago.com/216-224

Subject to changes. Please also observe the further product documentation!

WAGO GmbH & Co. KG
Hansastr. 27
32423 Minden
Phone: +49571 887-0 | Fax: +49571 887-169
Email: info.de@wago.com | Web: www.wago.com

Do you have any questions about our products?
We are always happy to take your call at +49 (571) 887-44222.

	Item no.: 216-244 Ferrule; Sleeve for 1.5 mm ² / AWG 16; insulated; electro-tin plated; electrolytic copper; gastight crimped; acc. to DIN 46228, Part 4/09.90; black	www.wago.com/216-244
	Item no.: 216-246 Ferrule; Sleeve for 2.5 mm ² / AWG 14; insulated; electro-tin plated; electrolytic copper; gastight crimped; acc. to DIN 46228, Part 4/09.90; blue	www.wago.com/216-246
	Item no.: 216-266 Ferrule; Sleeve for 2.5 mm ² / AWG 14; insulated; electro-tin plated; electrolytic copper; gastight crimped; acc. to DIN 46228, Part 4/09.90; blue	www.wago.com/216-266
	Item no.: 216-264 Ferrule; Sleeve for 1.5 mm ² / AWG 16; insulated; electro-tin plated; electrolytic copper; gastight crimped; acc. to DIN 46228, Part 4/09.90; black	www.wago.com/216-264
	Item no.: 216-286 Ferrule; Sleeve for 2.5 mm ² / AWG 14; insulated; electro-tin plated; electrolytic copper; gastight crimped; acc. to DIN 46228, Part 4/09.90; blue	www.wago.com/216-286
	Item no.: 216-287 Ferrule; Sleeve for 4 mm ² / AWG 12; insulated; electro-tin plated; electrolytic copper; gastight crimped; acc. to DIN 46228, Part 4/09.90; gray	www.wago.com/216-287
	Item no.: 216-288 Ferrule; Sleeve for 6 mm ² / AWG 10; insulated; electro-tin plated; electrolytic copper; gastight crimped; acc. to DIN 46228, Part 4/09.90; yellow	www.wago.com/216-288
	Item no.: 216-289 Ferrule; Sleeve for 10 mm ² / AWG 8; insulated; electro-tin plated; electrolytic copper; gastight crimped; acc. to DIN 46228, Part 4/09.90; red	www.wago.com/216-289
	Item no.: 216-267 Ferrule; Sleeve for 4 mm ² / AWG 12; insulated; electro-tin plated; electrolytic copper; gastight crimped; acc. to DIN 46228, Part 4/09.90; gray	www.wago.com/216-267

Downloads

Documentation

Additional Information

Technical Section	2019 年4月3日	pdf	Download
Technical explanations		2.1 MB	

CAD/CAE-Data

CAE data

WSCAD Universe 828-334	URL	Download
------------------------	-----	----------

Subject to changes. Please also observe the further product documentation!

Environmental Product Compliance

Compliance Search

Environmental Product Compliance 828-334

URL

Download

Feedthrough terminal block; lever; Plate thickness: 3 mm; 16 mm²; Pin spacing 11.5 mm; 4-pole; CAGE CLAMP®; 16,00 mm²; gray

Installation Notes

Installation

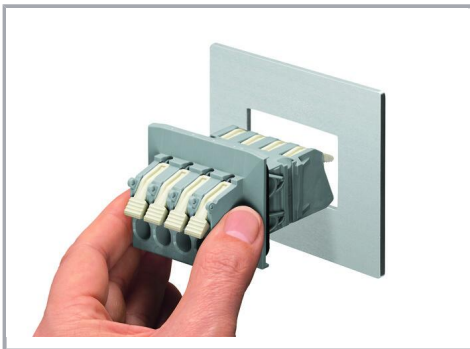

Insert terminal strip from the outside.

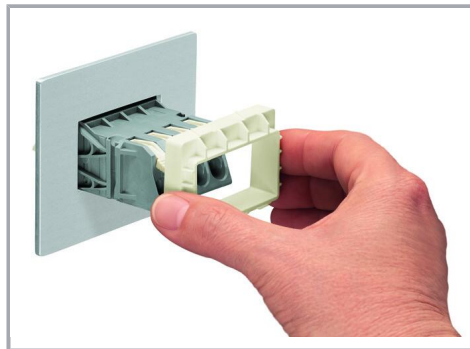

Snap the panel thickness adapter on from the inside.



Secure to panel via locking clip.

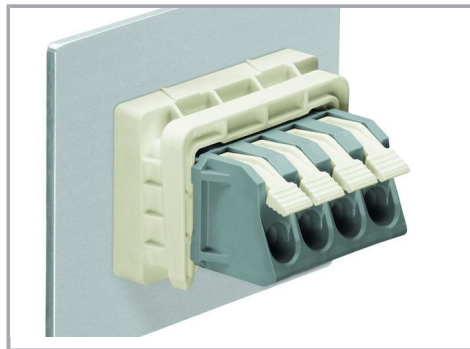

Mounted feedthrough terminal strip (internal)

Subject to changes. Please also observe the further product documentation!