



Duplex starter w/o alternator Size 1.75 Three phase full voltage Solid-state overload relay OLR amp range 10-40A Combination type Two 60A disconnect switches Encl NEMA type 4X 304 S. Steel Water/dust tight non-corrosive

| | |
|---|---|
| product brand name | Class 84 |
| design of the product | Duplex controller with two non-fusible disconnect switches without alternator |
| special product feature | ESP200 overload relay; Half-size controller |
| General technical data | |
| weight [lb] | 70 lb |
| Height x Width x Depth [in] | 34 × 25 × 8 in |
| touch protection against electrical shock | NA for enclosed products |
| installation altitude [ft] at height above sea level maximum | 6560 ft |
| ambient temperature [°F] | |
| • during storage | -22 ... +149 °F |
| • during operation | -4 ... +104 °F |
| ambient temperature | |
| • during storage | -30 ... +65 °C |
| • during operation | -20 ... +40 °C |
| country of origin | USA |
| Horsepower ratings | |
| yielded mechanical performance [hp] for 3-phase AC motor | |
| • at 200/208 V rated value | 10 hp |
| • at 220/230 V rated value | 10 hp |
| • at 460/480 V rated value | 15 hp |
| • at 575/600 V rated value | 15 hp |
| Contactors | |
| size of contactor | Controller half size 1 3/4 |
| number of NO contacts for main contacts | 3 |
| operating voltage for main current circuit at AC at 60 Hz maximum | 600 V |
| operational current at AC at 600 V rated value | 40 A |
| mechanical service life (operating cycles) of the main contacts typical | 10000000 |
| Auxiliary contact | |
| number of NC contacts at contactor for auxiliary contacts | 0 |
| number of NO contacts at contactor for auxiliary contacts | 1 |
| number of total auxiliary contacts maximum | 8 |
| contact rating of auxiliary contacts of contactor according to UL | 10A@600VAC (A600), 5A@600VDC (P600) |
| Coil | |
| type of voltage of the control supply voltage | AC |
| control supply voltage | |
| • at DC rated value | 0 ... 0 V |
| • at AC at 50 Hz rated value | 190 ... 220 V |
| • at AC at 60 Hz rated value | 220 ... 240 V |
| holding power at AC minimum | 8.6 W |

| | |
|--|--|
| apparent pick-up power of magnet coil at AC | 218 VA |
| apparent holding power of magnet coil at AC | 25 VA |
| operating range factor control supply voltage rated value of magnet coil | 0.85 ... 1.1 |
| percentual drop-out voltage of magnet coil related to the input voltage | 50 % |
| ON-delay time | 19 ... 29 ms |
| OFF-delay time | 10 ... 24 ms |
| Overload relay | |
| product function | |
| • overload protection | Yes |
| • phase failure detection | Yes |
| • asymmetry detection | Yes |
| • ground fault detection | Yes |
| • test function | Yes |
| • external reset | Yes |
| reset function | Manual, automatic and remote |
| trip class | CLASS 5 / 10 / 20 (factory set) / 30 |
| adjustable current response value current of the current-dependent overload release | 10 ... 40 A |
| tripping time at phase-loss maximum | 3 s |
| relative repeat accuracy | 1 % |
| number of NC contacts of auxiliary contacts of overload relay | 1 |
| number of NO contacts of auxiliary contacts of overload relay | 1 |
| operational current of auxiliary contacts of overload relay | |
| • at AC at 600 V | 5 A |
| • at DC at 250 V | 1 A |
| contact rating of auxiliary contacts of overload relay according to UL | 5A@600VAC (B600), 1A@250VDC (R300) |
| insulation voltage (Ui) | |
| • with single-phase operation at AC rated value | 600 V |
| • with multi-phase operation at AC rated value | 300 V |
| Disconnect Switch | |
| response value of switch disconnector | 60A / 600V |
| design of fuse holder | non-fusible |
| operating class of the fuse link | non-fusible |
| Enclosure | |
| degree of protection NEMA rating of the enclosure | NEMA 4x 304 stainless steel enclosure |
| design of the housing | dustproof, waterproof & resistant to corrosion |
| Mounting/wiring | |
| mounting position | Vertical |
| fastening method | Surface mounting and installation |
| type of electrical connection for supply voltage line-side | Box lug |
| tightening torque [lbf-in] for supply | 35 ... 35 lbf-in |
| type of connectable conductor cross-sections at line-side for AWG cables single or multi-stranded | 1x (14 ... 2 AWG) |
| temperature of the conductor for supply maximum permissible | 75 °C |
| material of the conductor for supply | AL or CU |
| type of electrical connection for load-side outgoing feeder | Screw-type terminals |
| tightening torque [lbf-in] for load-side outgoing feeder | 45 ... 45 lbf-in |
| type of connectable conductor cross-sections for AWG cables for load-side outgoing feeder single or multi-stranded | 1x (14 ... 2 AWG) |
| temperature of the conductor for load-side outgoing feeder maximum permissible | 75 °C |
| material of the conductor for load-side outgoing feeder | AL or CU |
| type of electrical connection of magnet coil | Screw-type terminals |
| tightening torque [lbf-in] at magnet coil | 5 ... 12 lbf-in |
| type of connectable conductor cross-sections of magnet coil for AWG cables single or multi-stranded | 2x (16 ... 12 AWG) |
| temperature of the conductor at magnet coil maximum permissible | 75 °C |
| material of the conductor at magnet coil | CU |
| type of electrical connection at contactor for auxiliary contacts | Screw-type terminals |

| | |
|---|---|
| tightening torque [lbf-in] at contactor for auxiliary contacts | 10 ... 15 lbf-in |
| type of connectable conductor cross-sections at contactor for AWG cables for auxiliary contacts single or multi-stranded | 1x (12 AWG), 2x (16 ... 14 AWG), 2x (18 ... 16 AWG) |
| temperature of the conductor at contactor for auxiliary contacts maximum permissible | 75 °C |
| material of the conductor at contactor for auxiliary contacts | CU |
| type of electrical connection at overload relay for auxiliary contacts | Screw-type terminals |
| tightening torque [lbf-in] at overload relay for auxiliary contacts | 7 ... 10 lbf-in |
| type of connectable conductor cross-sections at overload relay for AWG cables for auxiliary contacts single or multi-stranded | 2x (20 ... 14 AWG) |
| temperature of the conductor at overload relay for auxiliary contacts maximum permissible | 75 °C |
| material of the conductor at overload relay for auxiliary contacts | CU |

Short-circuit current rating

| | |
|---|---|
| design of the fuse link for short-circuit protection of the main circuit required | 10kA@600V (Class H or K); 100kA@600V (Class R or J) |
| certificate of suitability | NEMA ICS 2; UL 508; CSA 22.2, No. 14 |

Further information

Industrial Controls - Product Overview (Catalogs, Brochures,...)

www.usa.siemens.com/iccatalog

Industry Mall (Online ordering system)

<https://mall.industry.siemens.com/mall/en/us/Catalog/product?mlfb=US2:84EUE95WDG>

Service&Support (Manuals, Certificates, Characteristics, FAQs,...)

<https://support.industry.siemens.com/cs/US/en/ps/US2:84EUE95WDG>

Image database (product images, 2D dimension drawings, 3D models, device circuit diagrams, EPLAN macros, ...)

http://www.automation.siemens.com/bilddb/cax_de.aspx?mlfb=US2:84EUE95WDG&lang=en

Certificates/approvals

<https://support.industry.siemens.com/cs/US/en/ps/US2:84EUE95WDG/certificate>

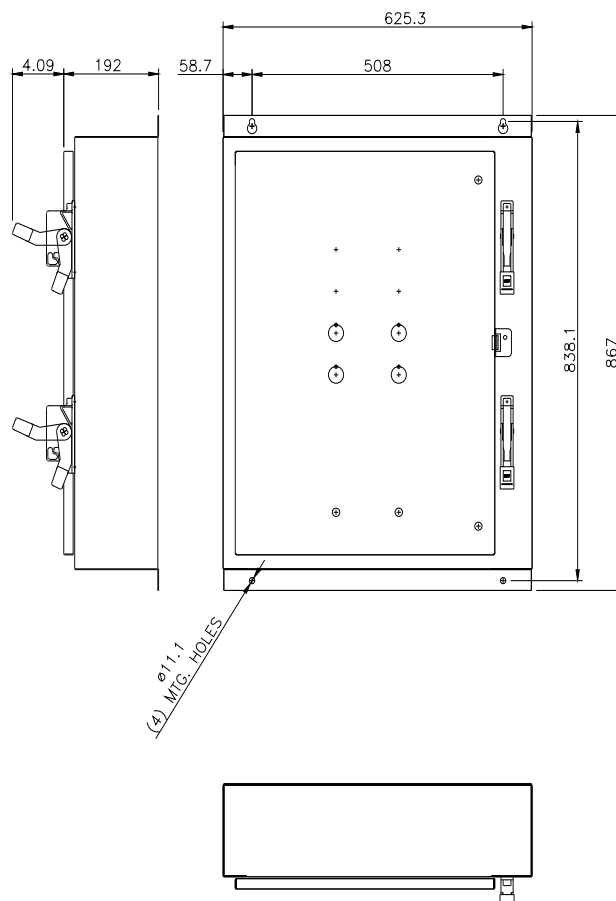

SCHEMATIC DIAGRAM

Class 83 & 84 Duplex W/Manual Alternation Size 0-4

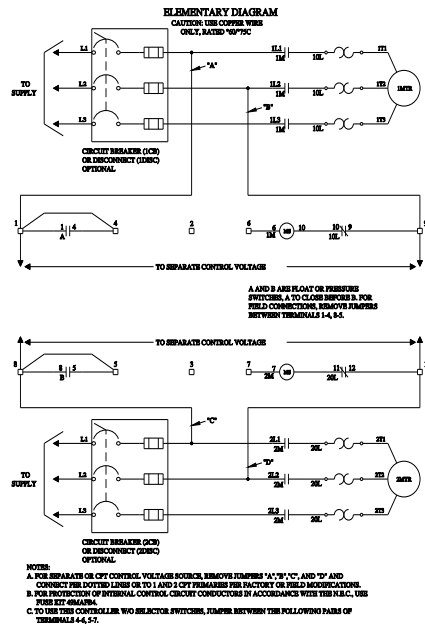

D68077003

last modified:

1/25/2022