



Reversing motor starter, Size 4, Three phase full voltage, Solid-state overload relay, OLR amp range 50-200A, Non-combination type, Enclosure type 12, Dust/drip proof for indoors, Standard width enclosure

product brand name	Class 22
design of the product	Full-voltage reversing motor starter
special product feature	ESP200 overload relay
<b>General technical data</b>	
weight [lb]	79 lb
Height x Width x Depth [in]	29 × 23 × 9 in
touch protection against electrical shock	NA for enclosed products
installation altitude [ft] at height above sea level maximum	6560 ft
ambient temperature [°F]	
• during storage	-22 ... +149 °F
• during operation	-4 ... +104 °F
ambient temperature	
• during storage	-30 ... +65 °C
• during operation	-20 ... +40 °C
country of origin	USA
<b>Horsepower ratings</b>	
yielded mechanical performance [hp] for 3-phase AC motor	
• at 200/208 V rated value	40 hp
• at 220/230 V rated value	50 hp
• at 460/480 V rated value	100 hp
• at 575/600 V rated value	100 hp
<b>Contactors</b>	
size of contactor	NEMA controller size 4
number of NO contacts for main contacts	3
operating voltage for main current circuit at AC at 60 Hz maximum	600 V
operational current at AC at 600 V rated value	135 A
mechanical service life (operating cycles) of the main contacts typical	5000000
<b>Auxiliary contact</b>	
number of NC contacts at contactor for auxiliary contacts	0
number of NO contacts at contactor for auxiliary contacts	1
number of total auxiliary contacts maximum	7
contact rating of auxiliary contacts of contactor according to UL	10A@600VAC (A600), 5A@600VDC (P600)
<b>Coil</b>	
type of voltage of the control supply voltage	AC
control supply voltage	
• at AC at 50 Hz rated value	380 ... 440 V
• at AC at 60 Hz rated value	440 ... 480 V
holding power at AC minimum	22 W
apparent pick-up power of magnet coil at AC	510 VA

apparent holding power of magnet coil at AC	51 VA
operating range factor control supply voltage rated value of magnet coil	0.85 ... 1.1
percentual drop-out voltage of magnet coil related to the input voltage	50 %
ON-delay time	18 ... 34 ms
OFF-delay time	10 ... 12 ms

### Overload relay

product function	
<ul style="list-style-type: none"> <li>• overload protection</li> <li>• phase failure detection</li> <li>• asymmetry detection</li> <li>• ground fault detection</li> <li>• test function</li> <li>• external reset</li> </ul>	<ul style="list-style-type: none"> <li>Yes</li> <li>Yes</li> <li>Yes</li> <li>Yes</li> <li>Yes</li> <li>Yes</li> </ul>
reset function	Manual, automatic and remote
trip class	CLASS 5 / 10 / 20 (factory set) / 30
adjustable current response value current of the current-dependent overload release	50 ... 200 A
make time with automatic start after power failure maximum	3 s
relative repeat accuracy	1 %
product feature protective coating on printed-circuit board	Yes
number of NC contacts of auxiliary contacts of overload relay	1
number of NO contacts of auxiliary contacts of overload relay	1
operational current of auxiliary contacts of overload relay	
<ul style="list-style-type: none"> <li>• at AC at 600 V</li> <li>• at DC at 250 V</li> </ul>	<ul style="list-style-type: none"> <li>5 A</li> <li>1 A</li> </ul>
contact rating of auxiliary contacts of overload relay according to UL	5A@600VAC (B600), 1A@250VDC (R300)
insulation voltage (Ui)	
<ul style="list-style-type: none"> <li>• with single-phase operation at AC rated value</li> <li>• with multi-phase operation at AC rated value</li> </ul>	<ul style="list-style-type: none"> <li>600 V</li> <li>300 V</li> </ul>

### Enclosure

degree of protection NEMA rating	12
design of the housing	dustproof and drip-proof for indoor use

### Mounting/wiring

mounting position	Vertical
fastening method	Surface mounting and installation
type of electrical connection for supply voltage line-side	Box lug
tightening torque [lbf-in] for supply	200 ... 200 lbf-in
type of connectable conductor cross-sections at line-side for AWG cables single or multi-stranded	1x (6 AWG ... 250 MCM)
temperature of the conductor for supply maximum permissible	75 °C
material of the conductor for supply	CU
type of electrical connection for load-side outgoing feeder	Box lug
tightening torque [lbf-in] for load-side outgoing feeder	200 ... 200 lbf-in
type of connectable conductor cross-sections for AWG cables for load-side outgoing feeder single or multi-stranded	1x (6 AWG ... 250 MCM)
temperature of the conductor for load-side outgoing feeder maximum permissible	75 °C
material of the conductor for load-side outgoing feeder	CU
type of electrical connection of magnet coil	Screw-type terminals
tightening torque [lbf-in] at magnet coil	5 ... 12 lbf-in
type of connectable conductor cross-sections of magnet coil for AWG cables single or multi-stranded	2x (16 ... 12 AWG)
temperature of the conductor at magnet coil maximum permissible	75 °C
material of the conductor at magnet coil	CU
type of electrical connection for auxiliary contacts	Screw-type terminals
tightening torque [lbf-in] at contactor for auxiliary contacts	10 ... 15 lbf-in
type of connectable conductor cross-sections at contactor for AWG cables for auxiliary contacts single or multi-stranded	1x (12 AWG), 2x (16 ... 14 AWG), 2x (18 ... 16 AWG)
temperature of the conductor at contactor for auxiliary contacts maximum permissible	75 °C

material of the conductor at contactor for auxiliary contacts	CU
type of electrical connection at overload relay for auxiliary contacts	Screw-type terminals
tightening torque [lbf-in] at overload relay for auxiliary contacts	7 ... 10 lbf-in
type of connectable conductor cross-sections at overload relay for AWG cables for auxiliary contacts single or multi-stranded	2x (20 ... 14 AWG)
temperature of the conductor at overload relay for auxiliary contacts maximum permissible	75 °C
material of the conductor at overload relay for auxiliary contacts	CU

**Short-circuit current rating**

design of the fuse link for short-circuit protection of the main circuit required	10kA@600V (Class H or K); 100kA@600V (Class R or J)
design of the short-circuit trip	Thermal magnetic circuit breaker
maximum short-circuit current breaking capacity (I <sub>cu</sub> )	
• at 240 V	10 kA
• at 480 V	10 kA
• at 600 V	10 kA
certificate of suitability	NEMA ICS 2; UL 508; CSA 22.2, No.14

**Further information**

Industrial Controls - Product Overview (Catalogs, Brochures,...)

[www.usa.siemens.com/ccatalog](http://www.usa.siemens.com/ccatalog)

Industry Mall (Online ordering system)

<https://mall.industry.siemens.com/mall/en/us/Catalog/product?mlfb=US2:22JUH320H>

Service&Support (Manuals, Certificates, Characteristics, FAQs,...)

<https://support.industry.siemens.com/cs/US/en/ps/US2:22JUH320H>

Image database (product images, 2D dimension drawings, 3D models, device circuit diagrams, EPLAN macros, ...)

[http://www.automation.siemens.com/bilddb/cax\\_de.aspx?mlfb=US2:22JUH320H&lang=en](http://www.automation.siemens.com/bilddb/cax_de.aspx?mlfb=US2:22JUH320H&lang=en)

Certificates/approvals

<https://support.industry.siemens.com/cs/US/en/ps/US2:22JUH320H/certificate>

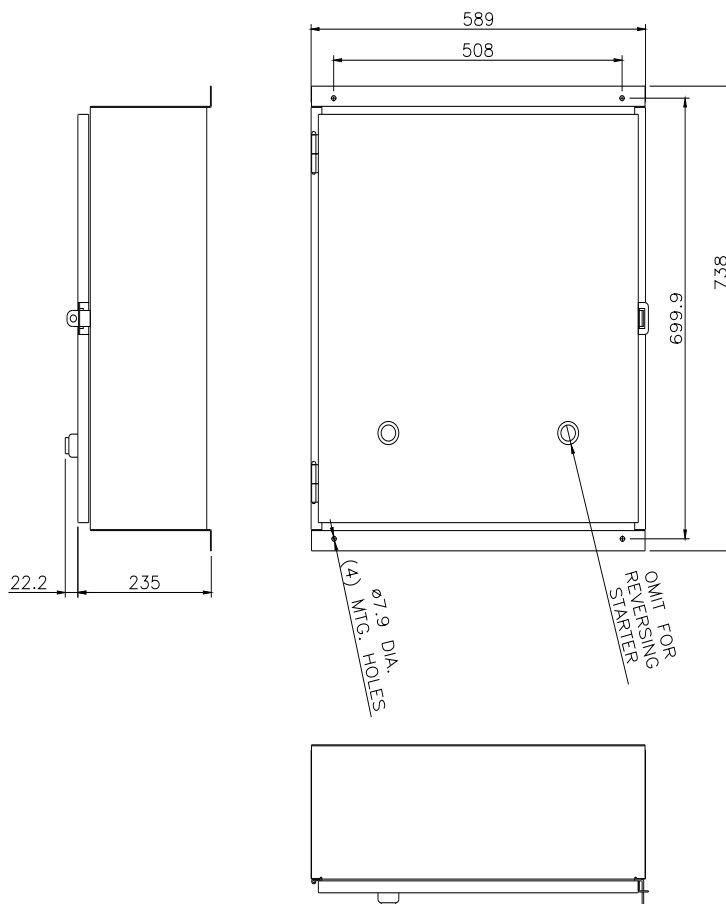

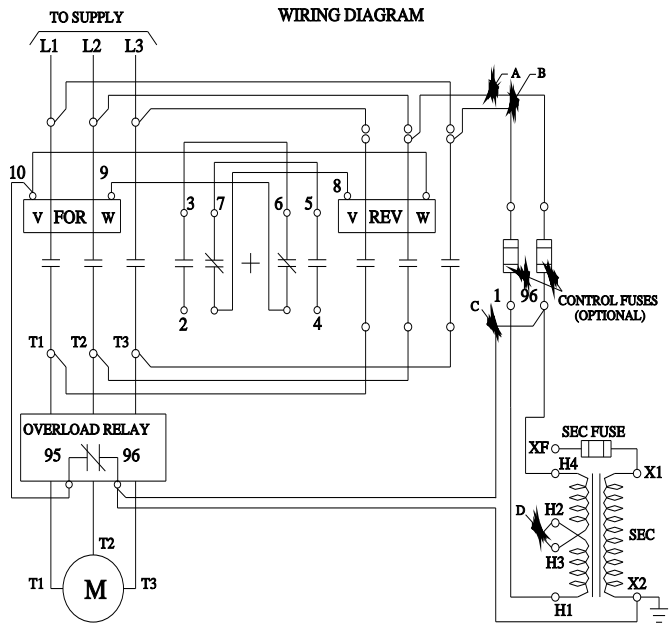

D46590003

last modified:

1/25/2022