



Non-reversing motor starter, Size 1, Three phase full voltage, Solid-state overload relay, OLRelay amp range 0.75-3.4a, 110 120/220 240VAC 60HZ coil, Combination type, 30Amp non-fusible disconnect Enclosure NEMA type 4/12, Water/dust tight for outdoors, Standard width enclosure

product brand name	Class 17 & 25
design of the product	Full-voltage non-reversing motor starter with non-fusible disconnect
special product feature	ESP200 overload relay; Dual voltage coil
<b>General technical data</b>	
Height x Width x Depth [in]	24 × 11 × 8 in
touch protection against electrical shock	(NA for enclosed products)
installation altitude [ft] at height above sea level maximum	6560 ft
ambient temperature [°F]	
• during storage	-22 ... +149 °F
• during operation	-4 ... +104 °F
ambient temperature	
• during storage	-30 ... +65 °C
• during operation	-20 ... +40 °C
<b>Horsepower ratings</b>	
yielded mechanical performance [hp] for 3-phase AC motor	
• at 200/208 V rated value	0.5 hp
• at 220/230 V rated value	0.75 hp
• at 460/480 V rated value	1.5 hp
• at 575/600 V rated value	2 hp
<b>Contactors</b>	
size of contactor	NEMA controller size 1
number of NO contacts for main contacts	3
operational current at AC at 600 V rated value	27 A
mechanical service life (operating cycles) of the main contacts typical	10000000
<b>Auxiliary contact</b>	
number of NC contacts at contactor for auxiliary contacts	0
number of NO contacts at contactor for auxiliary contacts	1
number of total auxiliary contacts maximum	8
contact rating of auxiliary contacts of contactor according to UL	345VA@115VAC / 768VA@240VAC
<b>Coil</b>	
type of voltage of the control supply voltage	AC
control supply voltage	
• at AC at 60 Hz rated value	110 ... 240 V
holding power at AC minimum	8.6 W
apparent pick-up power of magnet coil at AC	218 VA
apparent holding power of magnet coil at AC	25 VA
operating range factor control supply voltage rated value of magnet coil	0.85 ... 1.1
percentual drop-out voltage of magnet coil related to the input voltage	50 %

ON-delay time	19 ... 29 ms
OFF-delay time	10 ... 24 ms
<b>Overload relay</b>	
product function	
• overload protection	Yes
• phase failure detection	Yes
• asymmetry detection	Yes
• ground fault detection	Yes
• test function	Yes
• external reset	Yes
reset function	Manual, automatic and remote
trip class	CLASS 5 / 10 / 20 (factory set) / 30
adjustable current response value current of the current-dependent overload release	0.75 ... 3.4 A
make time with automatic start after power failure maximum	3 s
relative repeat accuracy	1 %
product feature protective coating on printed-circuit board	Yes
number of NC contacts of auxiliary contacts of overload relay	1
number of NO contacts of auxiliary contacts of overload relay	1
operational current of auxiliary contacts of overload relay	
• at AC at 600 V	5 A
• at DC at 250 V	1 A
contact rating of auxiliary contacts of overload relay according to UL	5
insulation voltage (Ui)	
• with single-phase operation at AC rated value	600 V
• with multi-phase operation at AC rated value	300 V
<b>Disconnect Switch</b>	
response value of switch disconnecter	30
design of fuse holder	non-fusible
operating class of the fuse link	non-fusible
<b>Enclosure</b>	
degree of protection NEMA rating	4
design of the housing	dustproof, waterproof & weatherproof
<b>Mounting/wiring</b>	
mounting position	vertical
fastening method	Surface mounting and installation
type of electrical connection for supply voltage line-side	Box lug
tightening torque [lbf-in] for supply	35 ... 35 lbf-in
type of connectable conductor cross-sections at line-side for AWG cables single or multi-stranded	1
temperature of the conductor for supply maximum permissible	75 °C
material of the conductor for supply	AL or CU
type of electrical connection for load-side outgoing feeder	Screw-type terminals
tightening torque [lbf-in] for load-side outgoing feeder	20 ... 24 lbf-in
type of connectable conductor cross-sections for AWG cables for load-side outgoing feeder single or multi-stranded	2
temperature of the conductor for load-side outgoing feeder maximum permissible	75 °C
material of the conductor for load-side outgoing feeder	CU
type of electrical connection of magnet coil	Screw-type terminals
tightening torque [lbf-in] at magnet coil	5 ... 12 lbf-in
type of connectable conductor cross-sections of magnet coil for AWG cables single or multi-stranded	2
temperature of the conductor at magnet coil maximum permissible	75 °C
material of the conductor at magnet coil	CU
type of electrical connection for auxiliary contacts	Screw-type terminals
tightening torque [lbf-in] at contactor for auxiliary contacts	10 ... 15 lbf-in
type of connectable conductor cross-sections at contactor for AWG cables for auxiliary contacts single or multi-stranded	1
temperature of the conductor at contactor for auxiliary contacts maximum permissible	75 °C

material of the conductor at contactor for auxiliary contacts	CU
type of electrical connection at overload relay for auxiliary contacts	Screw-type terminals
tightening torque [lbf-in] at overload relay for auxiliary contacts	7 ... 10 lbf-in
type of connectable conductor cross-sections at overload relay for AWG cables for auxiliary contacts single or multi-stranded	2
temperature of the conductor at overload relay for auxiliary contacts maximum permissible	75 °C
material of the conductor at overload relay for auxiliary contacts	CU
<b>Short-circuit current rating</b>	
design of the fuse link for short-circuit protection of the main circuit required	10
certificate of suitability	NEMA ICS 2; UL 508; CSA 22.2, No.14
<b>Further information</b>	

Industrial Controls - Product Overview (Catalogs, Brochures,...)

[www.usa.siemens.com/iccatalog](http://www.usa.siemens.com/iccatalog)

Industry Mall (Online ordering system)

<https://mall.industry.siemens.com/mall/en/us/Catalog/product?mlfb=US2:17DUB92NA>

Service&Support (Manuals, Certificates, Characteristics, FAQs,...)

<https://support.industry.siemens.com/cs/US/en/ps/US2:17DUB92NA>

Image database (product images, 2D dimension drawings, 3D models, device circuit diagrams, EPLAN macros, ...)

[http://www.automation.siemens.com/bilddb/cax\\_de.aspx?mlfb=US2:17DUB92NA&lang=en](http://www.automation.siemens.com/bilddb/cax_de.aspx?mlfb=US2:17DUB92NA&lang=en)

Certificates/approvals

<https://support.industry.siemens.com/cs/US/en/ps/US2:17DUB92NA/certificate>

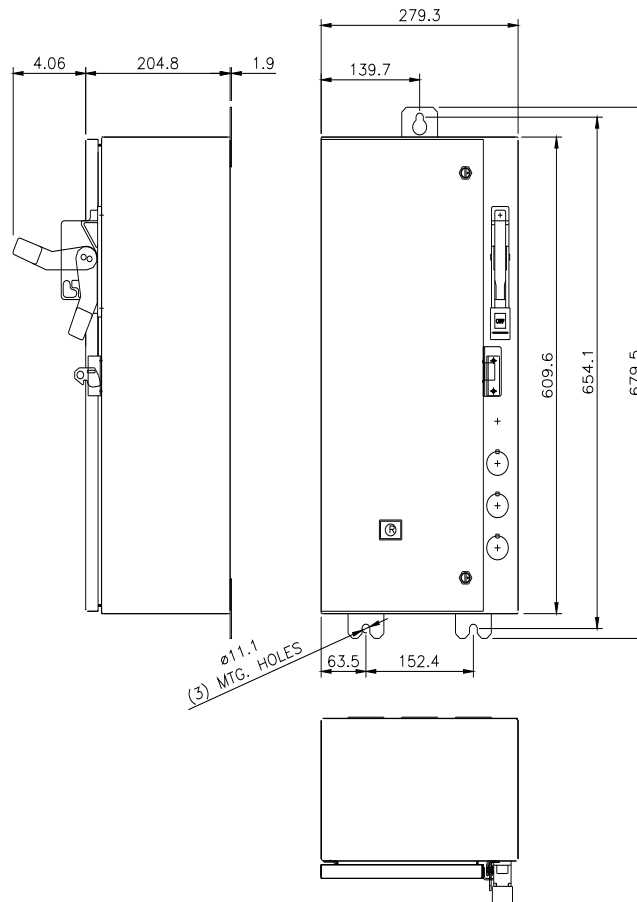

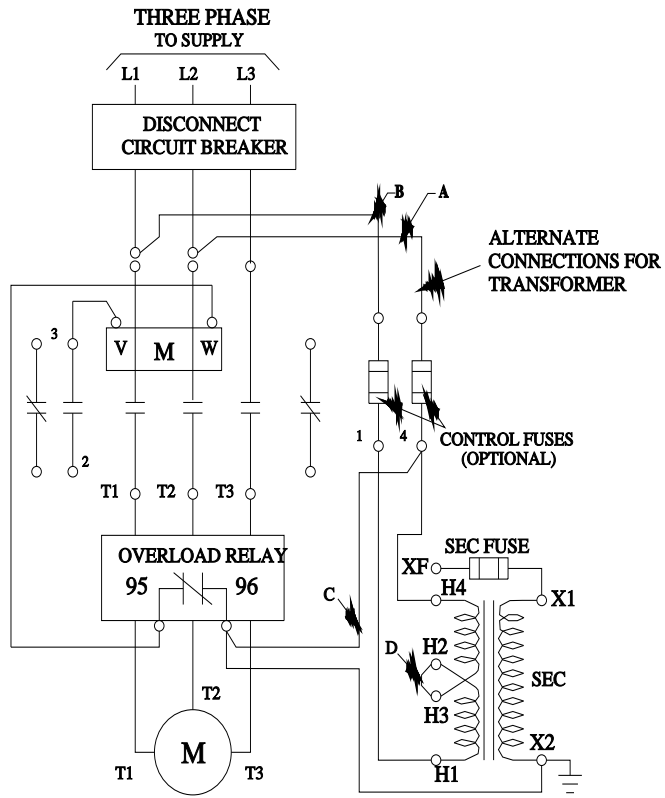

D68782001

last modified:

12/3/2022 