

REVISIONS			
REV	DESCRIPTION, ECN, EAR NO.	DATE	APP'D
A	PROPOSAL	MAR08/18	L.CHAN

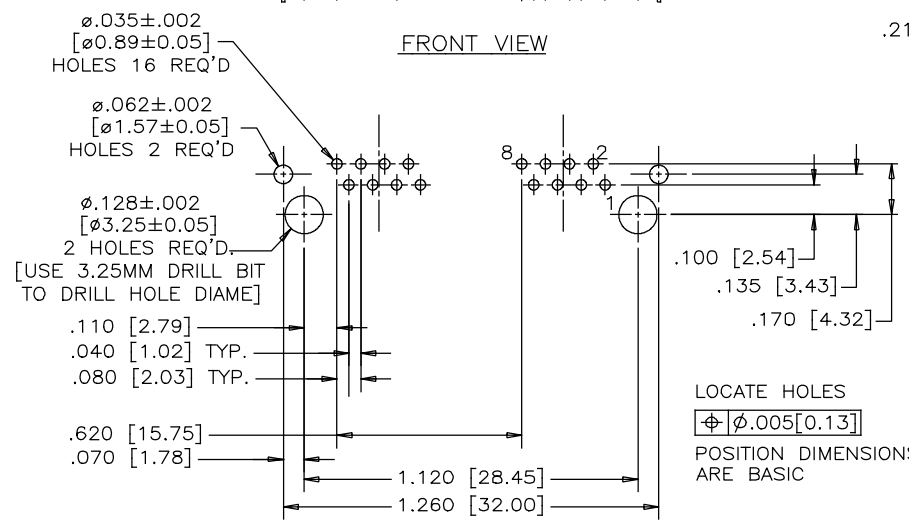

LOCATE HOLES
 $\phi .005 [0.13]$
 POSITION DIMENSIONS
 ARE BASIC

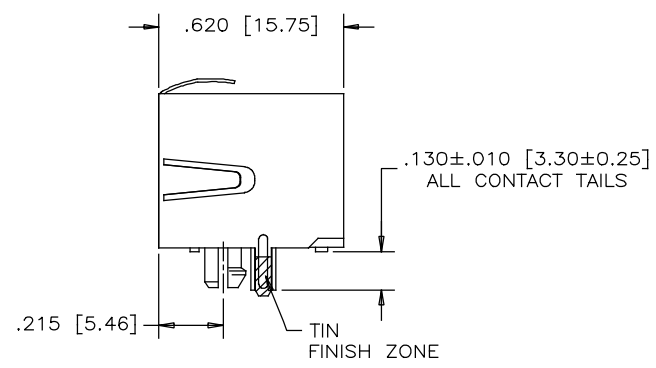
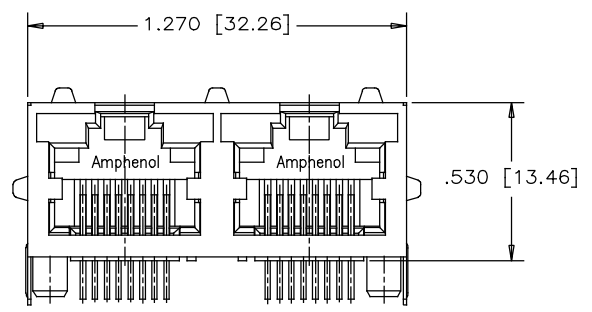

MATERIALS:
 PLASTIC HOUSING: HIGH TEMPERATURE THERMOPLASTIC
 FLAMMABILITY RATING UL 94V-0, COLOR BLACK

CONTACTS:
 PHOSPHOR BRONZE
 PLATING: GOLD PLATING ON MATING SURFACE.
 [SEE PART NUMBER FOR THICKNESS]
 50 μ" [1.27 MICRONS]
 MIN. NICKEL UNDERPLATE
 100 μ" [2.54 MICRONS]
 MIN. MATTE TIN ON CONTACT TAILS.

SHIELD: STAINLESS STEEL WITH TIN FINISH ON SOLDER TAIL

AMPHENOL PART NUMBER: RJHSE-X380-A2

GOLD PLATING
 E=RJ45 FLAT CONTACT 6u"
 G=RJ45 FLAT CONTACT 15u"
 J=RJ45 FLAT CONTACT 30u"
 5=RJ45 FLAT CONTACT 50u"

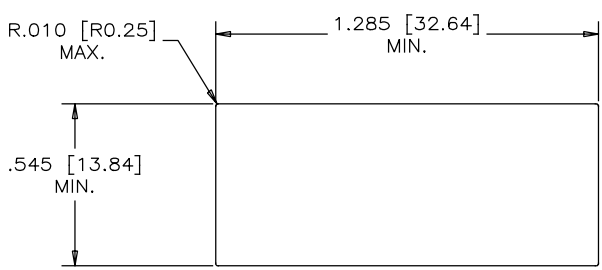

RECOMMENDED PANEL CUTOUT

UNLESS SPECIFIED OTHERWISE	DRAWN W.QIU	DATE MAR09/18	Amphenol Canada Corp. www.amphenolcanada.com
PRIMARY UNITS INCH	CHECKED L.CHAN	MAR09/18	
SECONDARY MILLIMETERS	M.E. APP'D		TITLE
REFERENCE IN PARENTHESES	Q.A. APP'D		2 PORT HIGH SPEED MODULAR JACK, 8P8C, SHIELDED, WITHOUT LED OPTIONS .130" LONG CONTACT TAILS - RoHS COMPLIANT
GENERAL TOLERANCES	DWG APPR.		DWG. NO.
1 DECIMAL PLACE	ENG. REL. NO.		P-RJHSE-X380-A2
2 DECIMAL PLACES ±0.020	REF.		REV A
3 DECIMAL PLACES ±0.015	THIRD ANGLE PROJECTION	DO NOT SCALE DRAWING	CODE ID NO. 03554 DWG SIZE: C SCALE: N/A SHEET 1 OF 1
ANGULAR DEGREES ±1.0°			

THIS DOCUMENT CONTAINS PROPRIETARY INFORMATION AND SUCH INFORMATION MAY NOT BE DISCLOSED TO OTHERS FOR ANY PURPOSE OR USED FOR MANUFACTURING PURPOSES WITHOUT WRITTEN PERMISSION FROM AMPHENOL CANADA CORP.