

CLIFF

DUALSLIM CAT.6 RJ45 RIGHT ANGLE FEEDTHROUGH CONNECTOR

Can be front or rear mounted in the panel

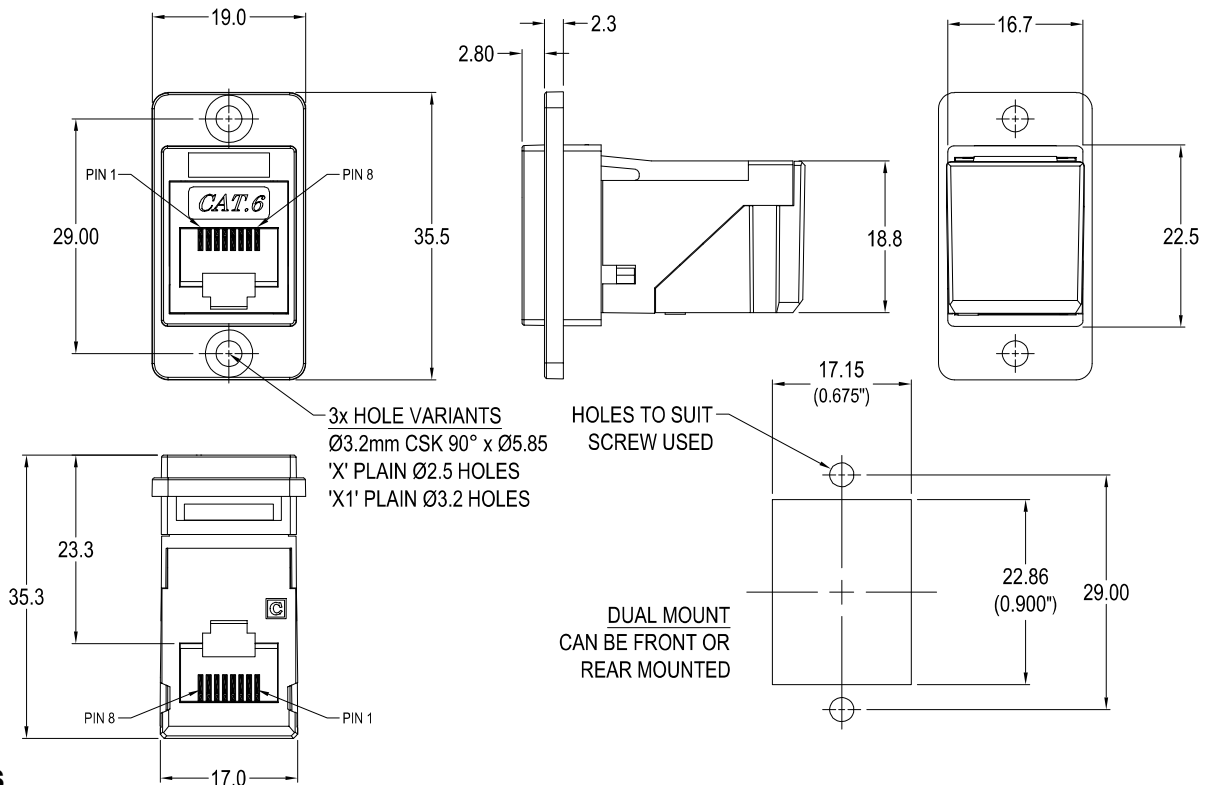
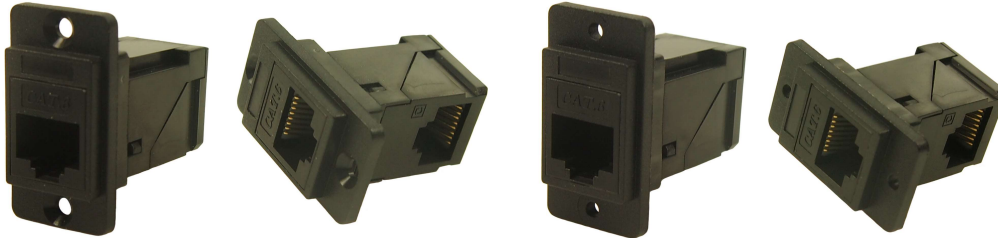

VARIANTS

Part No.

CP30752

RAFT DUALSLIM Cat.6 RJ45 Black plastic frame, CSK holes

CP30752X

RAFT DUALSLIM Cat.6 RJ45 Black plastic frame, Ø2.5 PLAIN holes

CP30752X1

RAFT DUALSLIM Cat.6 RJ45 Black plastic frame, Ø3.2 PLAIN holes

Feedthrough Features

- Fits standard rectangular cutout.
- Front or rear mounting through the panel.
- Various hole mounting options.
- No soldering or punch termination. Use standard cable for each connector style.
- Low rear profile.
- 90° or right angle rear cable entry.

General:

Please note: Functionality is affected by cable quality, length and cable wiring configuration.

Material:

1. RJ45 In-Line Coupler: ABS UL94-V2
2. RJ45 In-Line Coupler Contact:
Phosphor Bronze, gold plating.

3. PCB: FR4

4. Frame: Polyamide UL94-V2

Performance:

1. T568A & T568B wiring.
2. Meet ISO/IEC 11801 and EN50173
3. Meet ANSI/TIA/EIA 568B.2
4. Rating: 125VAC RMS 1.5A
5. Operating Temperatures: Min -10°C Max +60°C