

PSI-MOS-RS422/FO 850 T Serial to Fiber Converter

 perle.com/products/serial-extenders/psi-mos-rs422-fo850t-rs422-to-dual-fiber.shtml

4-wire RS422 and RS485 to Redundant Fiber

- Two ST type fiber connectors
- Extend serial data up to 2.6 miles
- Immune to EMI, RFI and transient surges
- Point-to-point or star configuration
- Terminal Block for 4-wire RS422/RS485 Connections

For applications where redundancy is required, the PSI-MOS-RS422/FO 850 T Serial to Fiber Converter transparently connects 4-wire RS422/RS485 and INTERBUS devices to two fiber optic cables. By transmitting serial data over optical fiber, these serial media converters provide an economical path to extend the reach of RS422 and RS485 devices. The serial data input is transmitted out both fiber ports to different locations or back-up systems.



Expandable Serial to Fiber Network infrastructures

Up to ten (10) Serial to Fiber Converters can be grouped together using the TBUS DIN Rail bus system for voltage and data. This allows the serial converter to operate in additional network topology environments:

- as a star coupler, taking the serial data input signal and distributing it to up to 20 Fiber optic output ports
- linear structure can be used to network several RS422/RS485 devices to form a master/slave structure

Long Distance Serial Data Transmission over Fiber

With the FO 850 T Serial to Fiber Converter you can extend your serial data transmission up to 4.2km (2.6 miles). Therefore, any two pieces of asynchronous serial equipment, located miles apart, can communicate at full duplex over fiber optic cable at rates up to 2 Mbps.

EMI, RFI and Transient Surge Immunity

Another advantage of the FO 850 T fiber optic transmission system is the electrically isolated connection of devices. Electromagnetic interference (EMI) is a common phenomenon in typical environments like industrial plants, warehouses and factory floors. This interference can cause corruption of data over RS422 or copper-based Ethernet links. Data transmitted over fiber optic cable however is completely immune to this type of noise, thus preventing the negative effects of voltage equalization currents and electromagnetic interference on the data cables. A Serial to Fiber Media Converter therefore enables you to inter-connect your serial devices over fiber ensuring optimal data transmission, increased availability of the system, and improved network design flexibility for point-to-point connections and star structures.

Flexible Fiber Optic Connections

The FO 850 T operates at 850 nm wavelength, using a separate LED emitter and photo-detector on ST type connectors. Almost any multimode glass fiber size can be used including 50/125 m, 62.5/125 m, and 200/230 m.

Power Budget Considerations

Calculating the power budget is critically important with planning the fiber optic link. The optical power budget is the amount of light required to transmit data successfully over distance through a fiber-optic connection. The amount of light energy available within the setup will dictate the length of the fiber optic cable run between serial media converters within the network. Optical power budgets are critical to help businesses avoid signal distortion. [To learn how to calculate optical power budget read our technical note.](#) Transmit and receive dBm can be found in the Hardware specifications.

High Quality Features and Support

The FO 850 T are also equipped with comprehensive diagnostic functions to increase system availability, simplify start-up and permanently monitor the optical transmission quality. The integrated optical diagnostics allow permanent monitoring of the FO paths during installation and operation. The floating switch contact is activated when the signal level on the fiber optic paths reaches a critical level. This early alarm generation enables critical system states to be detected before they result in failure. These cost and time saving features, along with free worldwide technical support, make the FO 850 T serial to fiber converter the smart choice for IT professionals.

- Supply voltage and data signals routed through via DIN rail connectors
- Connections can be plugged in using a COMBICON screw terminal block
- Redundant power supply possible by means of optional system power supply unit
- High-quality electrical isolation between all interfaces (INTERBUS, fiber optic ports, power supply, DIN rail connector)
- Approved for use in zone 2
- Integrated optical diagnostics for continuous monitoring of fiber optic paths
- Intrinsically safe fiber optic interface (Ex op is) for direct connection to devices in zone 1
- Floating switch contact for leading alarm generation in relation to critical fiber optic paths
- Automatic data rate detection for all data rates up to 2 Mbps

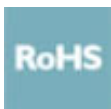

PSI-MOS-RS422/FO 850 T Technical Specifications

Ambient conditions

Ambient temperature (operation)	-20 °C ... 60 °C
Ambient temperature (storage/transport)	-40 °C ... 85 °C
Permissible humidity (operation)	30 % ... 95 % (non-condensing)
Altitude	5000 m (For restrictions see manufacturer's declaration)
Degree of protection	IP20
Noise immunity	EN 61000-6-2:2005

Standards and Regulations

Electromagnetic compatibility	Conformance with EMC Directive 2014/30/EU
Type of test	Vibration resistance in acc. with EN 60068-2-6/IEC 60068-2-6
Test result	5g, 10-150 Hz, 2.5 h, in XYZ direction
Type of test	Shock in acc. with EN 60068-2-27/IEC 60068-2-27
Test result	15g, 11 ms period, half-sine shock pulse
Shock	15g in all directions in acc. with IEC 60068-2-27
Noise emission	EN 55011
Noise immunity	EN 61000-6-2:2005
Connection in acc. with standard	CUL
Standards/regulations	EN 61000-4-2 EN 61000-4-3 EN 61000-4-4 EN 61000-4-5 EN 61000-4-6
Vibration (operation)	In acc. with IEC 60068-2-6: 5g, 150 Hz
Conformance	CE-compliant
ATEX	II 3 G Ex nA nC IIC T4 Gc X II (2) G [Ex op is Gb] IIC (PTB 06 ATEX 2042 U) II (2) D [Ex op is Db] IIIC (PTB 06 ATEX 2042 U)
UL, USA/Canada	Class I, Zone 2, AEx nc IIC T5 Class I, zone 2, Ex nC nL IIC T5 X

Class I, Div. 2, Groups A, B, C, D

Optical interface FO

Number of FO ports	2
Transmit capacity, minimum	-4.6 dBm (200/230 μ m) -17.6 dBm (50/125 μ m) -13.6 dBm (62,5/125 μ m)
Minimum receiver sensitivity	-33.2 dBm
Wavelength	850 nm
Transmission length incl. 3 dB system reserve	2800 m (With F-K 200/230 10 dB/km with quick mounting connector) 4200 m (with F-G 50/125 2.5 dB/km) 4800 m (with F-G 62,5/125 3.0 dB/km)
Transmission medium	PCF fiber Multi-mode fiberglass
Transmission protocol	Transparent to protocol for RS-422 interface
Connection method	B-FOC (duplex ST®)

General

Transmission channels	2 (1/1) RD, TD, full duplex
Bit distortion, input	\pm 35 % (permitted)
Bit distortion, output	< 6.25 %
Electrical isolation	VCC // RS-422
Test voltage data interface/power supply	1.5 kVrms (50 Hz, 1 min.)
Electromagnetic compatibility	Conformance with EMC Directive 2014/30/EU
Noise emission	EN 55011
Net weight	209.58 g
Housing material	PA 6.6-FR
Color	green
MTBF	178 Years (Telcordia standard, 25°C temperature, 21% operating cycle (5 days a week, 8 hours a day)) 26 Years (Telcordia standard, 40°C temperature, 34.25% operating cycle (5 days a week, 12 hours a day))

Conformance	CE-compliant
ATEX	<p>II 3 G Ex nA nC IIC T4 Gc X (Please follow the special installation instructions in the documentation!)</p> <p>II (2) G [Ex op is Gb] IIC (PTB 06 ATEX 2042 U) (Please follow the special installation instructions in the documentation!)</p> <p>II (2) D [Ex op is Db] IIIC (PTB 06 ATEX 2042 U) (Please follow the special installation instructions in the documentation!)</p>
UL, USA/Canada	<p>Class I, Zone 2, AEx nc IIC T5</p> <p>Class I, zone 2, Ex nC nL IIC T5 X</p> <p>Class I, Div. 2, Groups A, B, C, D</p>
Digital outputs	
Output name	Relay output
Output description	Alarm output
Number of outputs	1
Maximum switching voltage	60 V DC 42 V AC
Limiting continuous current	0.46 A
Power supply	
Nominal supply voltage	24 V DC (With UL approval)
Supply voltage range	18 V DC ... 30 V DC
Max. current consumption	130 mA
Typical current consumption	120 mA (24 V DC)
Connection method	COMBICON plug-in screw terminal block
Serial interface	
Interface 1	RS-422 interface in acc. with ITU-T V.11, EIA/TIA-422, DIN 66348-1
Operating mode	Full duplex
Connection method	Pluggable screw connection
Transmission medium	Copper
Transmission length	≤ 1000 m (depending on the data rate, with shielded, twisted data cable)
Termination resistor	220 Ω 100 Ω

220 Ω

Conductor cross section
solid min. 0.2 mm²

Conductor cross section
solid max. 2.5 mm²

Conductor cross section
flexible min. 0.2 mm²

Conductor cross section
flexible max. 2.5 mm²

Conductor cross section
AWG min. 24

Conductor cross section
AWG max. 14

Serial transmission speed ≤ 2 Mbps

Dimensions

Width 35 mm

Height 99 mm

Depth 103 mm

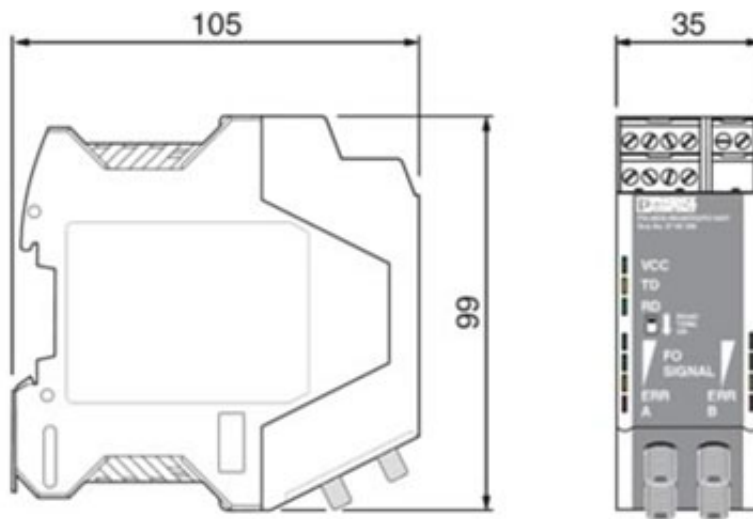

Environmental Product Compliance

China RoHS

Environmentally Friendly Use Period = 50

Approvals

cUL Listed
cULus Listed
UL Listed
ATEX
EAC
DNV
cUL Recognized
cULus Recognized
UL Recognized

Commercial data

Packing unit	1
Weight per piece	248.5 g
Country of origin	Germany
Warranty	1 Year

Classifications

eCl@ss 4.0	27230207
eCl@ss 4.1	27230207
eCl@ss 5.0	27230207
eCl@ss 5.1	27230207
eCl@ss 6.0	27230207
eCl@ss 7.0	27230207
eCl@ss 8.0	19179290
eCl@ss 9.0	19179290
ETIM 2.0	EC001423
ETIM 3.0	EC001423
ETIM 4.0	EC001423
ETIM 5.0	EC000310
ETIM 6.0	EC000310

UNSPSC 6.01	30211506
-------------	----------

UNSPSC 7.0901	39121008
---------------	----------

UNSPSC 11	39121008
-----------	----------

UNSPSC 12.01	39121008
--------------	----------

UNSPSC 13.2	43222604
-------------	----------

PSI-MOS-RS422/FO 850 T Serial to Fiber Media Converter Applications

- near heavy electrical equipment
- in environments with electrical (EMI) or radio (RFI) interference
- in environments with transient surges
- in industrial plants, warehouses and factory floors
- enabling asynchronous serial equipment to communicate at full duplex, with rates up to 2 Mbps, over optical fiber

Point-to-point connections between serial devices over fiber

Configure the point-to-point connection redundantly to increase availability by using two PSI-MOS-RS422/FO 850 T Serial to Fiber Converters. Easily convert a data link from a single copper cable out to two fiber optic cables.

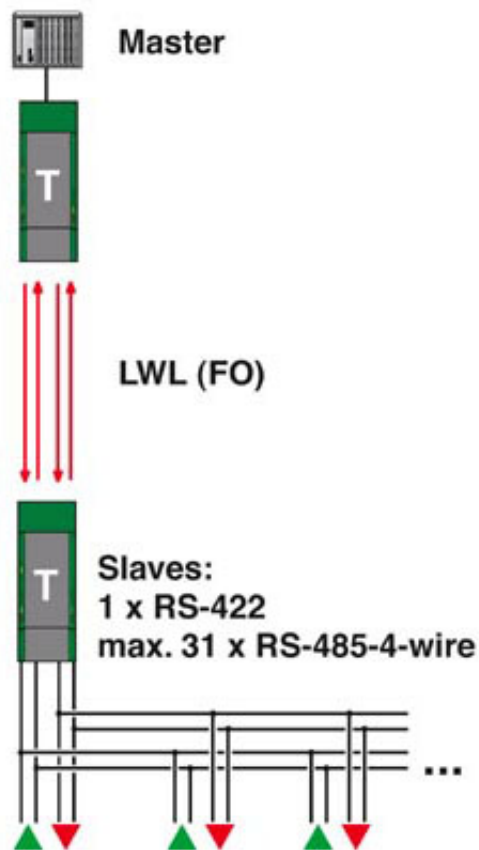

Redundant Star Topology Network

You can network RS-422/RS485 4-wire devices within a star structure as a master/slave network. Depending on the number of star lines required, several PSI-MOS-RS232/FO 850 T Serial to Fiber Converters are connected to TBUS DIN Rail bus systems for voltage and data. This makes up to 20 fiber optic ports available. Cross-wiring for serial data and the supply voltage is provided automatically by the DIN rail connector.

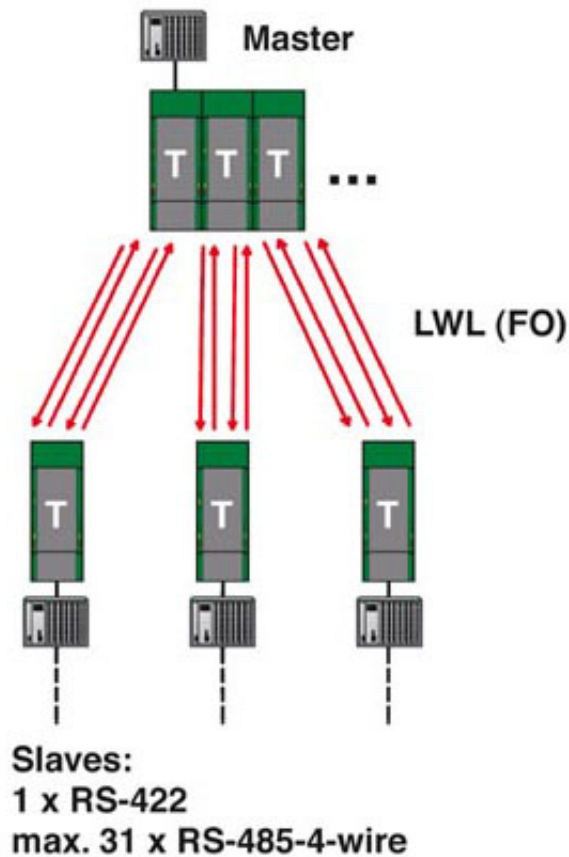

Linear Networks

The fiber optic linear structure can be used to network several RS-422/RS-485 4 wire devices to form a master/slave structure. In this case, it must be possible to address all the serial devices via communication software. PSI-MOS-RS422/FO 850 E serial to fiber converters are used at the beginning and end of the fiber optic line. PSI-MOS-RS422/FO 850 T serial to fiber converters with two fiber optic ports are used along the line. You can use up to ten PSI-MOS-RS2422/FO devices along the line in a linear structure. The cascability of the fiber optic devices is limited by the data rate.

Data Rate	Number of devices
≤ 115.2 kbps	15
≤ 187.5 kbps	7
≤ 375 kbps	5
≤ 500 kbps	3
≤ 2000 kbps	2

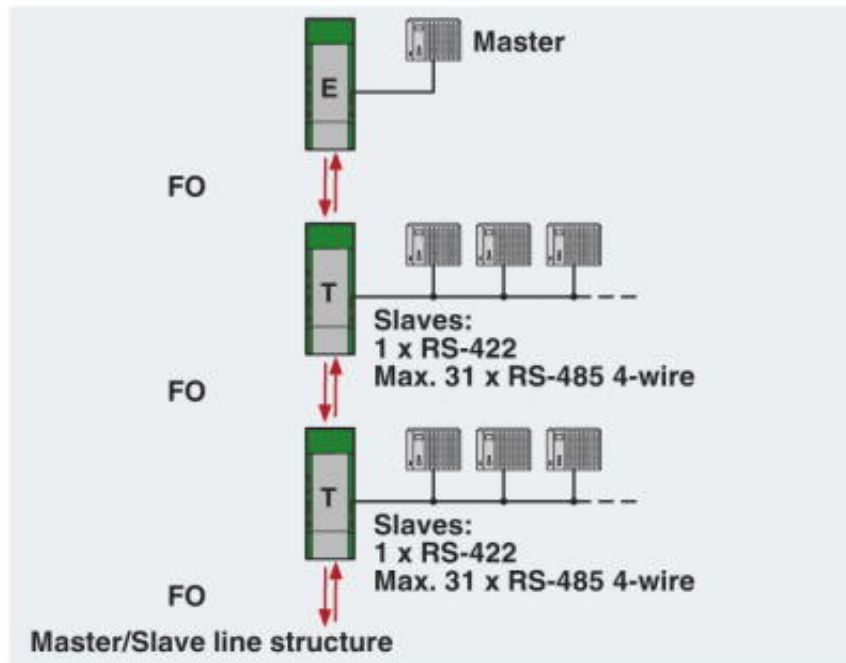

INTERBUS Networks

PSI-MOS-RS422/FO 850 E converters also allow you to create INTERBUS networks with FO technology. For standard INTERBUS connections, the REMOTE IN and REMOTE OUT interfaces are converted to fiber optics using one PSI-MOS-RS422/FO 850 T terminal device each. This set-up provides redundant fiber optic connections.

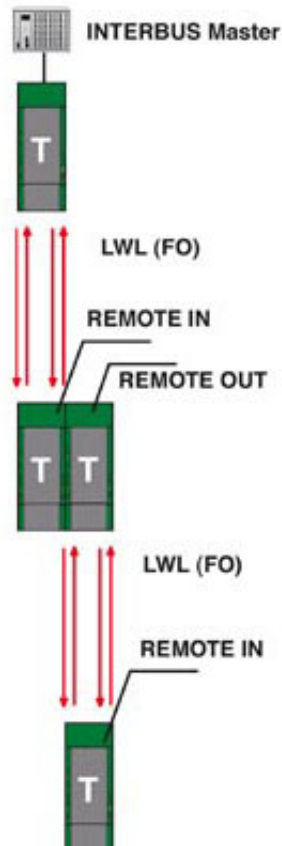

Block Diagram

