

Key Features & Benefits:

- Field Installable Konex Controls
- Standard 5' Cord
- White or Black Finish Available
- 1–10V Dimmable

Project: _____

Date: _____

Catalog #: _____

Notes: _____

Product Specifications:

Wattage: 180W
 Kelvin: 5000K
 Lumens: 28,800 lm
 Efficacy: 160 lm/W
 Input Power: 120–277 VAC
 Beam Angle: 90°
 Surge Protection: 6kV
 CRI: >82
 Temperature Operating Range: -40°F to 122°F
 Estimate L70 Lifetime 160,000 hrs Calculated Per TM21



Easy Field Installation of Optional Sensors or Konex Power Pack Controls with No Extra Wiring using Removable Shorting Cap



Ordering Guide:

ESL	TYPE	WATTAGE	GENERATION	KELVIN	FINISH	BEAM ANGLE	OPTOINS
ESL	ERHB (ERHB) Economy Round High Bay	180W (180W) 180 WATTS	1 (1) 1st Generation	50 (50) 5000 Kelvin	ff (WH) White (BK) Black	90D (90D) 90 Degrees	

FACTORY INSTALLED OPTIONS

CS3W6P	Cord set, 3 conductor, 18 gauge, white, 6 foot length, straight blade plug
CS3B6P	Cord set, 3 conductor, 18 gauge, black, 6 foot length, straight blade plug
CS3B6TL5	Cord set, 3 conductor, 18 gauge, black, 6 foot length, twist lock, NEMA I5–15 — 120VAC
CS3B6TL6	Cord set, 3 conductor, 18 gauge, black, 6 foot length, twist lock, NEMA I6–15 — 240VAC
CS3B6TL7	Cord set, 3 conductor, 18 gauge, black, 6 foot length, twist lock, NEMA I7–15 — 277VAC
CS5W6W	Cord set, 5 conductor, 16 gauge, white, whip end
CS5B6W	Cord set, 5 conductor, 16 gauge, black, whip end
EM30*	Emergency backup battery unit, auto test function, 40 watts output, 90 minutes min, 100–347VAC input, 170VDC output, factory install, title 20

*EMG is not compatible with KNX accessories

FIELD INSTALLED ACCESSORIES

ESL-KNX-2-FS7-RPP*	Konex Occupancy Sensor with integrated RPP Controller. Field installed utilizing twist lock design for Twist Connect Receptacles. 120–277 VAC with power statistics
ESL-KNX-2-RPP-003*	Konex Power Pack Relay Controller. Use with Konex sensors or wall switches for wireless dimming control. Field installed utilizing twist lock design for Twist Connect Receptacles. 120–277 VAC with power statistics.
ESL-9OCC-LV-HDD	High bay occupancy sensor for twist connect receptacles, 12V input, daylight harvesting, 40ft mounting, microwave sensor, step dimming
ESL-6OCC	High bay occupancy sensor for twist connect receptacles, 12–24 VDC, daylight harvesting, 40ft mounting, PIR sensor
ESL-ACCS-CMA2	Conduit mount adapter for ERHB Series. 3/4" NPT. Side hole allows for wiring in conduit
ESL-RHB1-LOOP	Stainless steel eye bolt mount
ESL-ERHB1-ff-TM	Trunnion mount for ERHB Series: (BK) black finish, (WH) white finish, (BZ) bronze finish
ESL-ERHB1-WG-BKBZ	Wire guard cover for ERHB Series. Black finish. Field installed.
ESL-ERHB1-WG-WH	Wire guard cover for ERHB Series. White finish. Field installed.
ESL-ERHB1-ARF-S	Aluminum reflector for ERHB Series. 90W and 135W. Field installed.
ESL-ERHB1-ARF-L	Aluminum reflector for ERHB Series. 180W. Field installed.
ESL-ERHB1-PCRF-S	PC reflector for ERHB Series 90W and 135W
ESL-ERHB1-PCRF-L	PC reflector for ERHB Series 180W
ESL-EMG-REM1	Hand-held remote to programmer for EM30
ESL-REM-100	Hand-held remote for 9OCC, 6OCC

*EMG is not compatible with KNX accessories

Catalog Data:

ITEM#	WATTAGE	KELVIN	MAX LUMEN OUTPUT	EFFICACY (lm/W)	DIMENSIONS	DLC QPL CODE
ESL-ERHB-90W-150-WH-90D	90	5000K	15,783	162	10.85" x 3.95"	S-XNH2WJ
ESL-ERHB-90W-150-BK-90D						
ESL-ERHB-135W-150-WH-90D	135	5000K	22,080	162	10.85" x 3.95"	S-7CADOS
ESL-ERHB-135W-150-BK-90D						
ESL-ERHB-180W-150-WH-90D	180	5000K	29,959	162	12.42" x 3.95"	S-0WF0B9
ESL-ERHB-180W-150-BK-90D						

Lumen Ambient Temperature (LAT) Multipliers:

AMBIENT		LUMEN MULTIPLIER
0 °C	32 °F	1.02
10 °C	50 °F	1.01
20 °C	68 °F	1.00
25 °C	77 °F	1.00
30 °C	86 °F	1.00
40 °C	104 °F	0.99
50 °C	122 °F	0.96

Comparison Technology:

SYSTEM WATTS	DESCRIPTION
90	175W Metal Halide
135	250W Metal Halide
180	400W Metal Halide

Unified Glare Rating (UGR):

BEAM ANGLE	UGR
60°	27
120°	32.7
90° (Aluminum Reflector)	22.7

LED Lumen Maintenance:

SYSTEM WATTS	HOURS			
	0	25,000	50,000	100,000
90	100%	94%	90%	80%
135	100%	94%	89%	79%
180	100%	92%	87%	76%



Electrical Load — Standard Voltage:

SYSTEM WATTS	INPUT CURRENT				INPUT VOLTAGE	INPUT FREQUENCY	INPUT CURRENT	POWER FACTOR	THD	OPERATING TEMPERATURE	SURGE PROTECTION	DIMMING
	120 VAC	208 VAC	240 VAC	277 VAC								
90	0.75	0.43	0.38	0.32	120–277 VAC	50/60 Hz	1.1 AMP@120 VAC					
135	1.13	0.65	0.56	0.49	120–277 VAC	50/60 Hz	1.4 AMP@120 VAC	>0.9	<15%	-40°F to 122°F (-40°C to 50°C)	6kV/4kV per ANSI C82.77-5- 2015	1–10V 12V Aux
180	1.50	0.87	0.75	0.65	120–277 VAC	50/60 Hz	2.2 AMP@120 VAC					

Dimensions:

90 Watt and 135 Watt

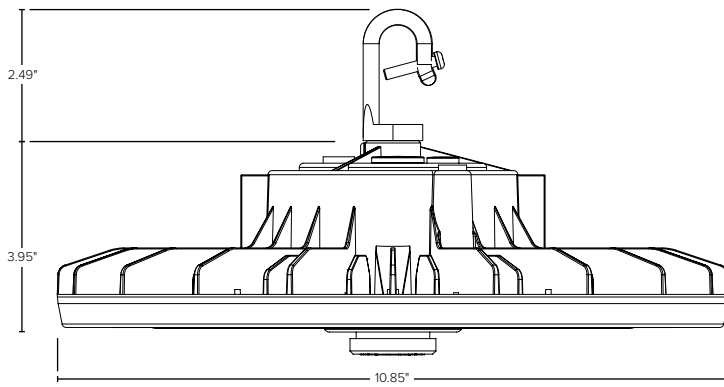

180 Watt

