



ATX LED Consultants Inc  
1108 Lavaca Ste 110 #489  
Austin TX, 78701  
512 377 6052  
<http://atx-led.com>

## AL-WS-010v smart 0-10v Dimmer switch with 3-Way, DALI or DC power



### Product Description - wall switch with 0-10v output and Tunable White

This wall switch has four major applications

- as a smart wall switch for controlling many LED drivers via manual switch, DMX or DALI
- as a simple stand alone 0-10v wall switch for controlling LED lighting via 0-10v controls.
- for tunable white applications with color and brightness controls for 2 0-10v switches
- for motor speed and direction control using 0-10v operation.

External LED drivers can be 0-10 type, PWM type, DMX or DALI. This wall switch creates a simple multi master bus that controls the LED drivers. It optionally works with our Hue Emulating Hub – allowing a large network to be controlled by App or Voice.

### Wall Switch with Lighting control bus

Up to 63 of the AL-WS-010v can be wired in parallel to form a large multi master bus. The output of the bus can be either DMX or DALI. You can mix and match DMX and DALI LED drivers as needed. Each switch can have a unique address – or the same address can be used many times. When the same address is re-used – each one operates as a virtual 3-Way switch. Allowing the same LED driver to be controlled by multiple wall switches.

A proven rocker switch and brightness slider leverages mass production of 120 VAC switches, for a low voltage application – any casual user requires no training, no App to use this switch.

### Smart control hub option

Connect a single Hub to the network. Our ZWD hub emulates the Philips Hue device and allows integration with Control 4, with Amazon Alexa and Google Home .

### DMX interface option for DMX LED drivers

One AL-DALI-DMX device connects up to 63 switches to a DMX bus for control of any DMX based drivers. Up to 192 DMX addresses can be generated. See the AL-DALI-DMX device specs for details.

### DMX interface from DMX consoles

Your DMX console can now control audience white lighting. The AL-DMX-DALI device accepts data from your existing DMX console, and merges that with the physical wall switches. The resulting combined physical switch and DMX console allows house lighting to be controlled by the DMX Stage console during performance, and also controlled by staff when the stage is not managed.

### Dimming and Tunable White operation

The slider allows the brightness to be adjusted. A remote switch can also be used to adjust brightness. In addition – if you enter Tunable White mode – you can adjust the color temperature of CCT fixtures using either the DALI or DMX control method.

## Specifications

Power requirements	DA pins - DALI bus – 5 ma max
Input Voltage (DALI bus)	14 to 24 volts – ( DALI Bus)
Input Voltage ( without DALI )	24 volts via a 1800 ohm resistor
Power consumption	64 milliwatts @ 15 volts plus the load on the 0-10v outputs if any.
0 – 10v outputs	Off = 0 – 1 volt On is dimming from 1.2 volt to 10 volts
Protection	Reverse protection and static protection on all pins
Static Electricity	Ground Metal plate to protect from Static Discharge – please ground it.
Operating Temperature	0°C ~ 50°C
Size	108H (metal) 70H x 34 D x 42 W mm
Receive Addressing	Switch addressable by onboard DIP or use a DALI master to assign a short address or group
Transmit addressing	DALI standard 8 and 16 bits.
FCC and interference	All outputs are RF filtered for minimal interference
DMX support	See the AL-DALI-DMX device for control of a DMX universe
DALI BUS interface	DA Bus In and Out – 300 mA max AWG 18-24 gauge wire, spring terminals
3-Way switching – physical	Simple contacts on the N-Way / Gnd terminals via AWG 18 – 24 wire
3-Way switching – virtual	Switches operate in multi master mode Allowing virtual N-Way control

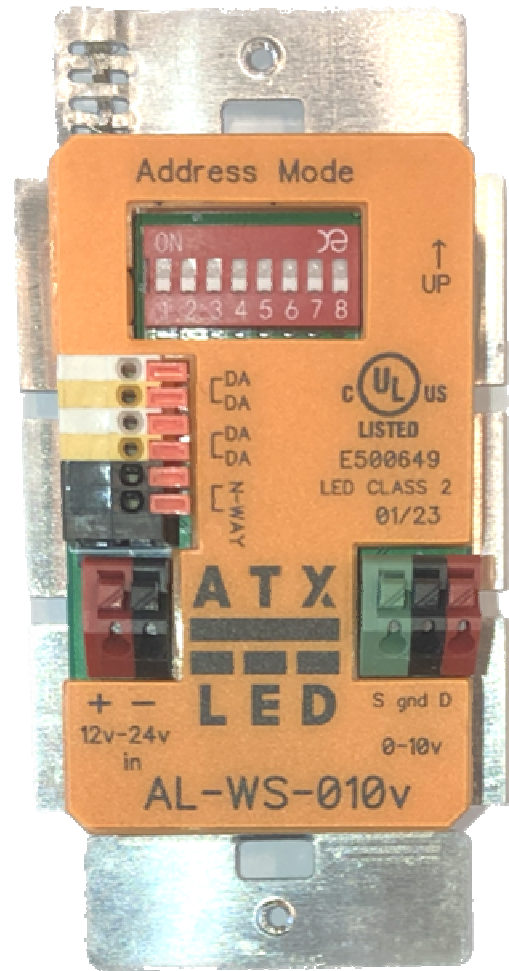

Connecting a AL-WS-010v to a DALI driver ( like Meanwell )

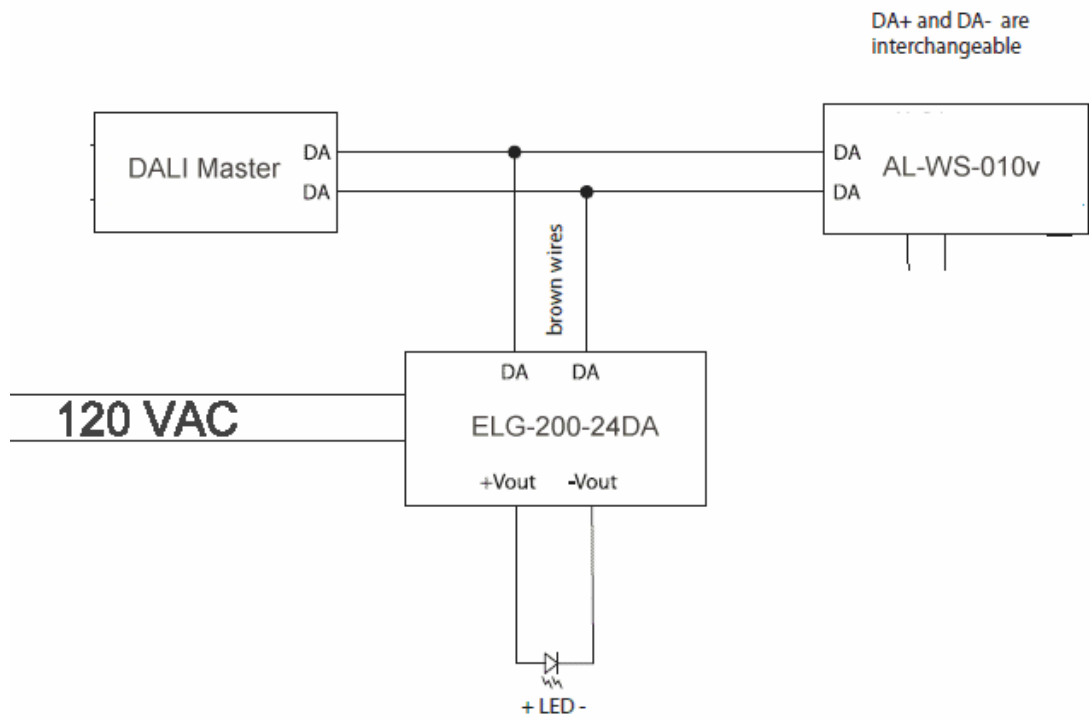

## Hardware Versions

2019 model

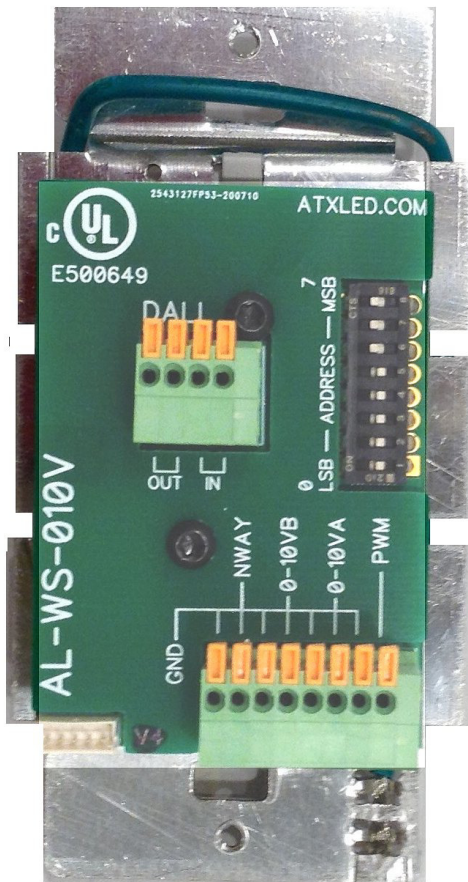

2023 model

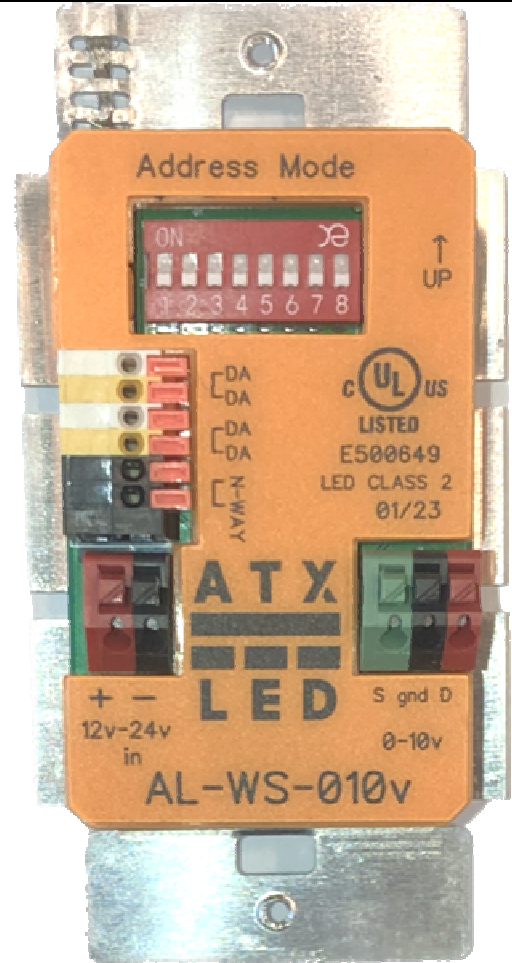

DALI power

On/Off Rocker switch

Slider on Right

( or resistor power )

DALI power

Momentary Switch

Slider on Left

( or simple DC input)

## 0-10v and 1-10v Outputs

Connect the 0-10v output(s) to your LED driver(s). The dimming range is .4% to 100% to 254 steps. There are two 0-10v outputs, A and B.

- A and B are the same in normal operation ( stand alone, until configured by DALI ) in fixed color mode
- A is cool white in CCT mode.
- B is the warm white in CCT mode.

In fact – by default these are 1-10v outputs – below 1 volt is OFF, 1.2 volts is minimum Dim. Use the Write Memory Bank in DALI to change the minimum and maximum voltage levels in 39.2 mV steps. For example: 31 = 1.2 volts ( the default for minimum voltage). Default is 31 for min and 255 for max.

Memory Bank 17 Minimum	Off Voltage	Minimum voltage	Memory Bank 18 Maximum	Maximum Brightness
31	0	1.2 Volts	255	10 volts
0-254 = value	0	Value times 39.2 mV	1 to 255	Value times 39.2mV

## Powering the AL-WS-010v by DALI

Power the switch via the DA pins, it needs about 4.5 mA to operate, minimum 13 volts. Polarity is not significant.. A DALI power supply has a nanosecond response time, current limiter of 260 mA with no inrush.

## Powering the AL-WS-010v by DC Voltage with DALI functions

1. 24 volt power supply – use a 1800 Ohm resistor in series to limit the maximum current – if you have 2 AL-WS-010v, then 1k ohm etc
2. 48 volt power supply – use a 6800 Ohm ¼ watt resistor in series, the device will limit the voltage to 24 volts, if you have 2 AL-WS-010v, then use 3.3k etc.

## Powering the AL-WS-010v by DC Voltage ( 2023 model )

Power the switch via the 12-24 DC input connector, it needs about 4.5 mA to operate, minimum 13 volts. This connector can also supply up to 10 mA from the DALI bus to an external device.

## Default Operation – Stand Alone

By default – the AL-WS-010v operates stand alone – no controller or master is required. By default – this is a DC powered 0-10v dimmer for any driver. Tandem mode requires the DALI bus.

# Hardware 3-Way Operation

## N-Way signal functions

The N-Way input has several functional options. A simple low cost switch or alarm contact can be used to activate this. The options are: 3-Way, Push Button or Dual Output. Default is simple 3-Way. No DALI operation is required.

## 3-Way Operation without configuration

If you need 3-Way switching please use a standard simple 2 or 3 way switch connected to the N-Way input. Simply connect an wire (solid CAT-3 or better is recommended, solid awg20 is best) between the N-WAY pins and a remote standard wall switch. If more control switches are needed – see our application note “AN-3Way” at <http://atxled.com/pdf>. No controller is required; an unlimited number of switches can control one light. 3-Way works in default or DALI modes. The N-Way input has an internal pull-up ( active low in computerspeak). The state of the N-Way input is XOR'd with the physical switch.

## Push Button Operation

With the Push Button method - a switch like the AL-WS-M or RH-253 can be used. Each momentary action on the N-Way pin will toggle the light on / off. At power on – the AL-WS-010v will observe the “ON’ time of any attached N-Way switch. If the N-Way is connected less than 500 milliseconds on 3 pushes after power on, then the AL-WS-010v operates in pushbutton mode. Each press of the push button will toggle an internal 3-Way function.

If the Push Button mode is incorrectly, set, then setting a normal switch to ON for more than 16 seconds will indicate to the AL-WS-010v that a regular ON/Off switch is connected.

## Remote Dimming

If Push Button mode is active – then the switch connected to the N-Way input can be used to dim the LED. Press and hold to dim the LED down. To Dim up – hold the switch down until it fades to low, and continue to hold so it will brighten back up again. If you reach to high a dim level – then release and press again – the level will decrease. Do not hold the button longer than 15 seconds – since this will trigger non-momentary mode.

## Door Jam Operation

With the default or Dual Output method enabled – a simple Normally Open or Normally Closed door alarm switch can be wired to the N-Way input. Then – when the door opens – the light will go on.

## Manual Address DALI Bus Transceiver

In this mode, – the device accepts and sends DALI ARC commands – so any DALI switch or master can connect to this device remotely for on/off/dimming – the 0-10v and PWM outputs are controlled by either the built in physical switch or from the DALI bus. DALI will override the On/Off DIM setting of the physical switch and force the output on or off. Physical Switch changes will be sent to the DALI bus on the individual, group or broadcast addresses set by dip switch. After a DALI command – flipping the physical switch will change the output again, with DALI acting as a virtual 3-Way switch – this is the main advantage of Transceiver mode vs. Transmitter mode.

Connect the DA+ and DA- to your DALI bus – polarity is not important – and a DALI power supply. Set the address according to the switches below. The device will respond to a single address, broadcast, or group commands.

This mode allows implementation with multiple switches controlling hundreds of watts of power in 2-way, 3-way and higher switch counts without complex wiring or DALI master.

The device receives and transmits only DALI ARC commands, plus the DALI Min/Max commands. See page 3 for the Min/Max logic. No DALI configuration commands will be processed. At power on the device will restore local outputs and remote DALI drivers to the last known values.

### Switch Settings for Manual Address DALI Transceiver

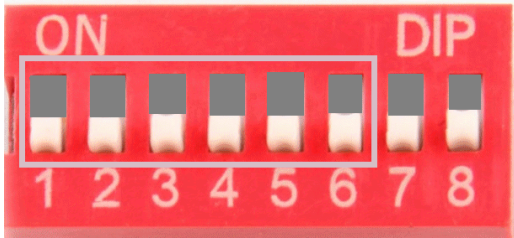
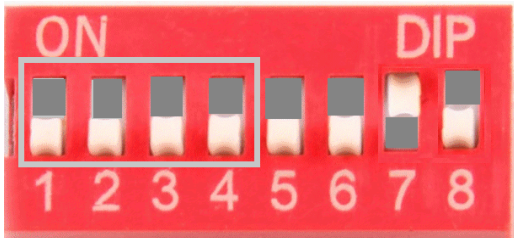
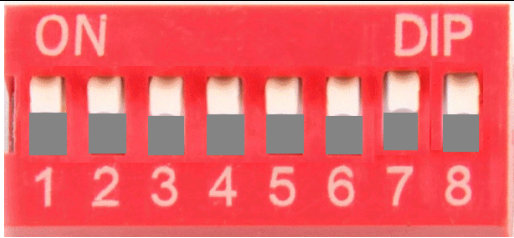
	Mode	Address
 <p>The image shows a red DIP switch strip with 8 switches numbered 1 to 8. Switches 2 and 3 are flipped up (ON), while switches 1, 4, 5, 6, 7, and 8 are flipped down (OFF). A white box highlights switches 2 and 3.</p>	<p>Individual Address</p> <p>Broadcast packets are received</p>	<p>The built in 0-10v and PWM outputs will receive commands on the DALI short address set by 1-6.</p> <p>Switch changes will be output on this group address</p> <p>LSB is switch 1, therefore DALI address 6 has switch 2 and 3 ON.</p>
 <p>The image shows a red DIP switch strip with 8 switches numbered 1 to 8. Switches 1, 2, and 3 are flipped up (ON), while switches 4, 5, 6, 7, and 8 are flipped down (OFF). A white box highlights switches 1, 2, and 3.</p>	<p>Group Address*</p> <p>Broadcast packets are received</p>	<p>The built in 0-10v and PWM outputs will receive commands on the DALI group address set by 1-4</p> <p>Switch changes will be output on this group address</p> <p>Set the DALI group address in 1-4, LSB is switch 1, therefore DALI group 3 has switch 1 and 2 ON</p>
 <p>The image shows a red DIP switch strip with 8 switches numbered 1 to 8. All switches (1 through 8) are flipped up (ON).</p>	<p>Broadcast</p>	<p>Switch values will be broadcast to all DALI fixtures, including those with no short addresses assigned.</p>

\* v48 or later

## Dip Switch settings for individual address

Code	Dip Switch Number								Code	Dip Switch Number							
	1	2	3	4	5	6	7	8		1	2	3	4	5	6	7	8
0	0	0	0	0	0	0	0	0	34	0	1	0	0	0	1	0	0
1	1	0	0	0	0	0	0	0	35	1	1	0	0	0	1	0	0
2	0	1	0	0	0	0	0	0	36	0	0	1	0	0	1	0	0
3	1	1	0	0	0	0	0	0	37	1	0	1	0	0	1	0	0
4	0	0	1	0	0	0	0	0	38	0	1	1	0	0	1	0	0
5	1	0	1	0	0	0	0	0	39	1	1	1	0	0	1	0	0
6	0	1	1	0	0	0	0	0	40	0	0	0	1	0	1	0	0
7	1	1	1	0	0	0	0	0	41	1	0	0	1	0	1	0	0
8	0	0	0	1	0	0	0	0	42	0	1	0	1	0	1	0	0
9	1	0	0	1	0	0	0	0	43	1	1	0	1	0	1	0	0
10	0	1	0	1	0	0	0	0	44	0	0	1	1	0	1	0	0
11	1	1	0	1	0	0	0	0	45	1	0	1	1	0	1	0	0
12	0	0	1	1	0	0	0	0	46	0	1	1	1	0	1	0	0
13	1	0	1	1	0	0	0	0	47	1	1	1	1	0	1	0	0
14	0	1	1	1	0	0	0	0	48	0	0	0	0	1	1	0	0
15	1	1	1	1	0	0	0	0	49	1	0	0	0	1	1	0	0
16	0	0	0	0	1	0	0	0	50	0	1	0	0	1	1	0	0
17	1	0	0	0	1	0	0	0	51	1	1	0	0	1	1	0	0
18	0	1	0	0	1	0	0	0	52	0	0	1	0	1	1	0	0
19	1	1	0	0	1	0	0	0	53	1	0	1	0	1	1	0	0
20	0	0	1	0	1	0	0	0	54	0	1	1	0	1	1	0	0
21	1	0	1	0	1	0	0	0	55	1	1	1	0	1	1	0	0
22	0	1	1	0	1	0	0	0	56	0	0	0	1	1	1	0	0
23	1	1	1	0	1	0	0	0	57	1	0	0	1	1	1	0	0
24	0	0	0	1	1	0	0	0	58	0	1	0	1	1	1	0	0
25	1	0	0	1	1	0	0	0	59	1	1	0	1	1	1	0	0
26	0	1	0	1	1	0	0	0	60	0	0	1	1	1	1	0	0
27	1	1	0	1	1	0	0	0	61	1	0	1	1	1	1	0	0
28	0	0	1	1	1	0	0	0	62	0	1	1	1	1	1	0	0
29	1	0	1	1	1	0	0	0	63	1	1	1	1	1	1	0	0
30	0	1	1	1	1	0	0	0									
31	1	1	1	1	1	0	0	0									
32	0	0	0	0	0	1	0	0									
33	1	0	0	0	0	1	0	0									

## Dip Switch Settings for Group 0-15

Code	Dip Switch Number							
	1	2	3	4	5	6	7	8
0	0	0	0	0	0	0	1	0
1	1	0	0	0	0	0	1	0
2	0	1	0	0	0	0	1	0
3	1	1	0	0	0	0	1	0
4	0	0	1	0	0	0	1	0
5	1	0	1	0	0	0	1	0
6	0	1	1	0	0	0	1	0
7	1	1	1	0	0	0	1	0
8	0	0	0	1	0	0	1	0
9	1	0	0	1	0	0	1	0
10	0	1	0	1	0	0	1	0
11	1	1	0	1	0	0	1	0
12	0	0	1	1	0	0	1	0
13	1	0	1	1	0	0	1	0
14	0	1	1	1	0	0	1	0
15	1	1	1	1	0	0	1	0

## Manual Address DALI bus Transmitter

The on-board switch will broadcast changes in the switch settings according to the address set below: The 0-10v / PWM outputs simply track the local dim and On/Off levels. Only DALI ARC and Trigger commands are transmitted. No DALI configuration commands will be processed.

Remote device Min and Max will be determined automatically and listened to as explained on page 3. Virtual 3-way is disabled – if another DALI master has turned a Light on/off – the rocker switch might need a double throw.

Power on DIM is set to turn the 0-10v and PMW outputs to off, no Power On DALI packets will be sent.

DALI command 271 is unused, the AL-WS-010v uses that command to implement Macro triggers – a DALI switch can send command 271 and a DALI master can convert that packet into a macro of actions.

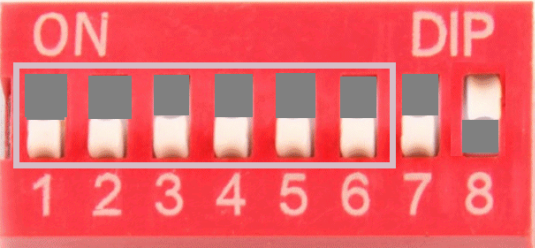
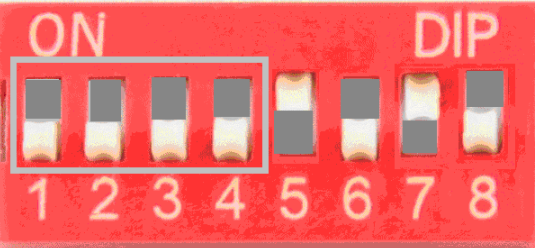
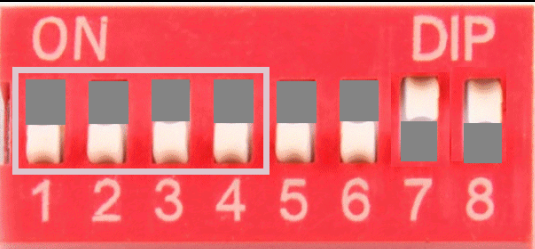
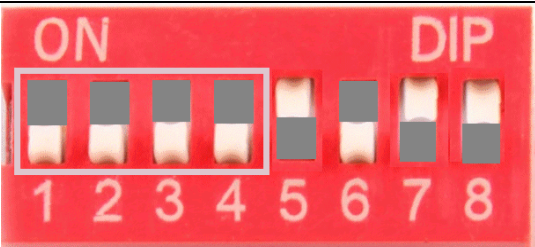
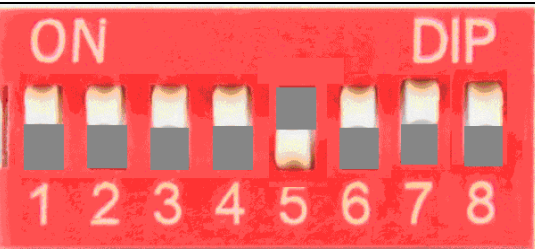

## Switch Settings for Manual Address DALI Transmitter

	Mode	Address
 <p>The image shows a red switch panel with 8 switches numbered 1 to 8. Switches 1 through 6 are in the 'ON' position (top half is white), and switches 7 and 8 are in the 'OFF' position (bottom half is white). A red box highlights switches 1 through 6. The word 'ON' is printed above switches 1-4, and 'DIP' is printed above switches 7-8.</p>	Individual Address	<p>The built in switch will transmit on the DALI short address set by 1-6</p> <p>LSB is switch 1, therefore DALI address 6 has switch 2 and 3 ON.</p>
 <p>The image shows a red switch panel with 8 switches numbered 1 to 8. Switches 1 through 4 are in the 'ON' position, switches 5 and 6 are in the 'OFF' position, and switches 7 and 8 are in the 'ON' position. A red box highlights switches 1 through 4. The word 'ON' is printed above switches 1-4, and 'DIP' is printed above switches 7-8.</p>	Trigger / Toggle	<p>Transmit 0xBF ( command 271 ) followed by:</p> <p style="text-align: center;"><b>16-31 off</b> <b>32-95 on</b></p>
 <p>The image shows a red switch panel with 8 switches numbered 1 to 8. Switches 1 through 4 are in the 'ON' position, switches 5 and 6 are in the 'OFF' position, and switches 7 and 8 are in the 'ON' position. A red box highlights switches 1 through 4. The word 'ON' is printed above switches 1-4, and 'DIP' is printed above switches 7-8.</p>	Group Address	<p>The built in switch will transmit the group address set by 1-4,</p> <p>LSB is switch 1, therefore DALI group 3 has switch 1 and 2 ON</p>
 <p>The image shows a red switch panel with 8 switches numbered 1 to 8. Switches 1 through 4 are in the 'ON' position, switches 5 and 6 are in the 'OFF' position, and switches 7 and 8 are in the 'ON' position. A red box highlights switches 1 through 4. The word 'ON' is printed above switches 1-4, and 'DIP' is printed above switches 7-8.</p>	Scene Address	<p>The built in switch will transmit the scene address set by 1-4,</p> <p>LSB is switch 1, therefore DALI address 6 has switch 2 and 3 ON.</p>
 <p>The image shows a red switch panel with 8 switches numbered 1 to 8. All switches 1 through 8 are in the 'ON' position. The word 'ON' is printed above switches 1-4, and 'DIP' is printed above switches 7-8.</p>	Broadcast	<p>Switch values will be broadcast to all DALI fixtures, including those with no short addresses assigned.</p>

## Configurable (full) DALI Operation

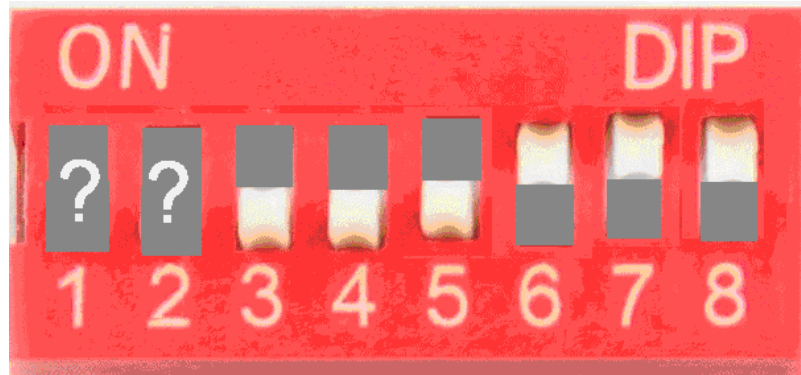

?? = 00 DT6 mode

?? = 10 DT8 mode

?? = 01 Fan mode

## Default DALI Operation

By default – the AL-WS-010v only responds to DALI broadcast commands. There is no individual group or short address assignment. Since the device accepts DALI broadcast commands – any DALI switch or master that sends broadcast commands can connect to this device remotely for on/off/dimming – the LED outputs are controlled by the switch or DALI broadcast packets. In Default mode – no DALI transmissions occur, the AL-WS-010v management functions can be read back in broadcast mode, but the responses will collide with other DALI devices.

## Full DALI Operation

For full DALI operation - connect your powered DALI bus to the DA+ and DA- pins (polarity is not significant) of the AL-WS-010v. The device responds to the provisioning commands from a DALI master. In order for addressable functions to work, a 'short' address [ 0 thru 63 ] needs to be assigned. This can be done by a DALI Master with provisioning features. Once a short address is assigned – the device can be understood to operate as two devices in one.

1) 0-10v driver with DALI control – the 0-10v outputs will have a unique DALI short address after provisioning. The 0-10v outputs are connected typically to LED's ( or motors ) and they can now be controlled by DALI commands from the bus. All DALI commands are supported. The actual address and group is defined and can be changed by the DALI master. See below.

2) Dimmer / Switch for other DALI drivers. After provisioning, the switch in this device is placed into either short address or Group mode – see below – flipping the switch, or the 3-way remote switches, or the dimming value will cause a DALI command to be sent internally to the PWM and 010v outputs as well as externally to the DALI bus.

3) Setting the short address to 255 will return the device to Broadcast receive-only mode.

Use an ATX LED Hub or similar provisioning tool to assign short and group addresses.

Note: The DALI bus and the Main and N-way switches all operate as a virtual 3-Way setup. DALI commands for On/Off will execute, making the physical switch Up/Down position potentially inverted.

# DALI Address Assignment

The AL-WS-010v from the factory has no DALI Short address by default. A DALI master is used during provisioning to assign a short address to the switch. This address will be used by default to report the user On/Off/Dim commands.

DALI commands also are used to determine the 3-Way state. Therefore, a DALI command that is received with the matching Group or Individual as the AL-WS-010v address will set any attached 0-10v light on or off – and all local switches – physical or virtual – will reflect that change – so that the next flip of any switch will turn the light off or on as intended. This may result in UP and DOWN being reversed – like any conventional 3-way mechanical switch. Use the momentary switch version to avoid the “3-way effect”.

The AL-WS-010v can send a group address instead of a short address, use memory bank 0:21 to implement this feature for 3-way controls.

## DALI Address Assignment - Auto – Grouping ( prior to v47)

In versions prior to v47, we have implemented a feature to allow inter switch communication without needing the ATX LED Hub. After v47, this task is managed by the Hub.

- If the short address is from address 16-63, then the switch will output these state changes using its short address, not a group address: This info is used by the DALI master to know the on/off state of every light, fan etc in the network. It can also be used as a trigger for macros to then create a sequence of light changes.
- If the short address assigned is from 0-15, then the built-in switch will send a Group On/Off/Dim command to the DALI bus each time the local status changes – On, Off, Dim, CCT – from the switch, slider or N-Way. This method allows multiple AL-WS-010v to be configured in ‘tandem’ – to all operate as one switch. Assign each device a short address between 0 and 15, then create a tandem virtual 3-way combo. To do this, use the DALI group feature. For example any ATX switch at short address 1, 2, 3, would each be members of group 1, 2, 3 – allowing perfect 3-Way control – mix AL-WS-010v, AL-WS-DR2 etc with different loads on each. Any AL-WS-DR2 or AL-WS-010v can thus be used as a 3-Way switch with full slider dimming.

## Minimum/Maximum slider range

After power up, the first OFF to ON transition of the switch will cause the switch to check the DALI bus for optimal slider operation. It will scan the DALI bus to find a driver with a matching address and will read back the Min / Max levels. In individual mode – just one address will be read. In Group mode – the 64 short addresses will be scanned to find a member belonging to the group – the first member discovered in the group will then be individually read and the search ends. The Min/Max levels will then be used for the bottom and top of the slider. Therefore, dimming control remains in the useful range. This scan of the DALI bus will occur with the next flip if the short address or the group address is changed (locally or by DALI command) or at power on. Finally – the device is listening to DALI bus Min / Max settings and storing them locally to adapt as needed to changing external fixtures. These settings do not change the 0-10v outputs – only the Slider Values – they are not stored and are refreshed if power is restarted.

# Software 3-Way Operation – DALI configuration

## Virtual 3-Way

The Virtual method uses 2 or more AL-WS-010v devices with the same short or group address which communicate via the DALI bus. Using the Virtual method just means that each AL-WS-010v will XOR it's physical switch state with the data it receives to its address from the DALI bus. The result allows unlimited numbers of switches to dim and control a common light. See section below on addressing.

By extension – DALI commands from other devices – such as AL-DALI-Wiz or AL-DALI-Pi receive commands from the Cloud ( Alexa, Google, etc) and output those on the DALI bus. These commands ( on, off, dim) override the local switch setting – operating as 3-Way switches. Therefore, rocker UP or DOWN will be inverted if a command has arrived from the cloud.

In FW 43 and later – the virtual 3-Way group address can be set by memory location 21. In all versions, if the address of the AL-WS-010v is set to 015, it will use that number for bus transactions as a group. See Auto Grouping.

## Physical N-Way operation

A momentary or rocker switch such as the AL-WS-M can be connected to the N-Way input of the AL-WS-010v. This will operate as documented on page 4.

## Group Operations

In all modes, if more than one Group is set – the device will respond to those groups – but will only broadcast physical switch and dim level changes using one group. Either the DIP switch is used, or the group set when a short address is set by a DALI master. If the short address is < 16, then the transmit group is that same address. See Auto Grouping

## Independent N-Way Operations

The N-Way input can be split from the main switch and used to send independent packets. Set the N-Way mode to 1, and set the 2<sup>nd</sup> Short Address register to these values: ( note: the local button could be out of sync with the state of the short address.

0-63	Send Short Address ARC	0-63
64-79	Send Group Address ARC	0-15
80-95	Send DAbus 271 (0xBF)	0-15
96-111	Send DAbus 271 + OnOff	16-31 off 32-95 on
127	Broadcast ARC	254

## Configurable (full) DALI Operation – simple DT6 mode

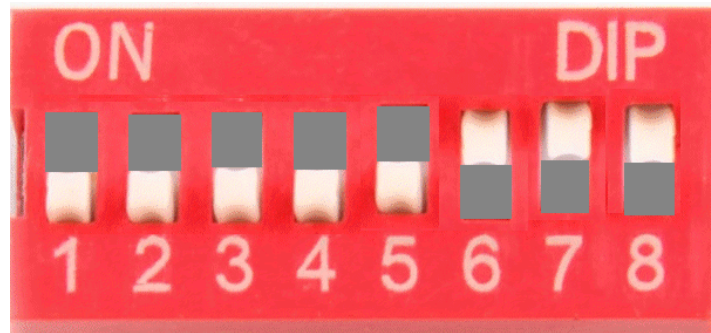

Set to this setting to enable configuration by a DALI Master

This mode allows the AL-WS-010v short address and all other settings to be set via a DALI configuration device – a DALI Master - for example the ATX LED Hub. Until configured – the device will only respond to broadcast commands, and will not transmit DALI packets on switch changes. By default – no short address is defined. Use a DALI Master to assign a short address – and all other DALI features.

For DALI operation - connect your powered DALI bus to the DA+ and DA- pins ( polarity is not significant ). DALI allows multiple masters – we use collision detection to avoid conflicts on the bus.

The device responds to the provisioning commands from a DALI controller. In order for individual, scenes and group addressable functions to work, a ‘short’ address [ 0 thru 63 ] needs to be assigned. This can be done by a DALI Master. Once a short address is assigned – the device can be understood to operate as two devices in one.

- 1) DALI driver – the 0-10v outputs will have a unique DALI short address after provisioning. This address is automatically assigned by the DALI Master – commands from the bus or will set the level of the 0-10v outputs. The 0-10v outputs are connected to the LED drivers to affect brightness. The device responses to Group and Scene commands as configured by the Master.
- 2) DALI Dimmer / Switch – after a short address is assigned, user actions locally will affect the local 0-10v outputs and will transmit these levels to the bus. There are two operation modes for this feature:
  - a) Single address – the changes by the user ( On/Off, Dimming ) will be sent to the bus to inform the Hub of the status and level of the lights.
  - b) Group mode – the switch can be set by the Master to operate in Group mode – this will cause the user initiated On/Off/Dimming to be set to the group defined – this allows all DALI devices that are members of this group to receive DALI On/Off and Dimming commands.

See Auto-Grouping instructions above.

## Configurable DALI Operation – DT8 CCT

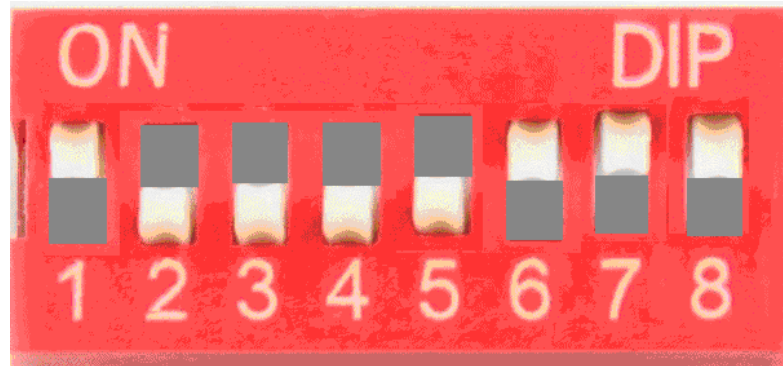

Set to this setting to enable configuration by a DALI DT8 Master

DALI DT8 operation allows color tuning using one DALI address. The short explanation is that the two 0-10v outputs can be used to drive two LED drivers attached to two strings of LEDs with different color temperatures. The result is human centric lighting on a large scale, one AL-WS-010v can then drive a large number of LEDs.

This mode allows the AL-WS-010v short address and all other settings to be set via a DALI configuration device – a DALI Master - for example the ATX LED Hub. Until configured – the device will only respond to broadcast commands, and will not transmit DALI packets on switch changes. By default – no short address is defined. Use a DALI Master to assign a short address – and all other DALI features.

For DALI operation - connect your powered DALI bus to the DA+ and DA- pins ( polarity is not significant ). Our implementation allows multiple masters – we use collision detection to avoid conflicts on the bus.

The device responds to the provisioning commands from a DALI controller. In order for individual, scenes and group addressable functions to work, a 'short' address [ 0 thru 63 ] needs to be assigned. This can be done by a DALI Master. Once a short address is assigned – the device can be understood to operate as two devices in one.

- 1) DALI driver – the 0-10v outputs will have a unique DALI short address after provisioning. This address is automatically assigned by the DALI Master – commands from the bus or will set the level of the 0-10v outputs. The 0-10v outputs are connected to the LED drivers to affect brightness. The device responses to Group and Scene commands as configured by the Master.
- 2) DALI Dimmer / Switch – before and after a short address is assigned, user actions locally will affect the local 0-10v outputs. After an address is assigned, the switch will transmit these levels to the bus. There are two operation modes for this feature:
  - a) Single address – the changes by the user ( On/Off, Dimming ) will be sent to the bus to inform the Hub of the status and level of the lights.
  - b) Group mode – the switch can be set by the Master to operate in Group mode – this will cause the user initiated On/Off/Dimming to be set to the group defined – this allows all DALI devices that are members of this group to receive DALI On/Off and Dimming commands.

See Auto-Grouping instructions below.

DT8 commands are documented in the IEC 62386 part 209 specifications. DALI masters support this and the details are embedded into the Master software and the firmware of this device.

## Tunable White Color Control to DALI bus (DT8)

When the switch is set to send CCT mode ( see CCT Mode ) – a CCT tunable DALI driver on the DALI bus will be given Color adjustment commands according to DALI type 8 commands. Therefore color can be adjusted in a CCT LED Fixture. The AL-WS-010v switch sends a broadcast command 272, with DTR set to 8, to enable CCT modes in the destination. The next command sets DTR1 and DTR to the color temperature using the command 231; finally a command 226 is sent to activate the color. Note – commands 231 and 226 can be individual or group or broadcast commands. The low end of the slider by default is 2700 K ( DALI 353) and the top end is 5000K ( DALI 0). These values are normally saved in the fixture. These DALI values can be updated from the DALI Master via memory bank settings.

## Tunable White 1-10v Color Control from DALI bus

When the switch has CCT enabled ( dip switches set to 225), the dual 1-10v outputs will operate in CCT mode – the values will be color shifted as selected. Therefore color can be adjusted if wired to a CCT LED fixture with dual 0-10v inputs.

If a DALI master is used to set the color by 0-10v, the AL-WS-010v switch listens for a broadcast command 272, with DTR set to 8, to enable CCT mode. The next command sets DTR1 and DTR to the color temperature using the command 231; finally a command 226 is sent to activate the color. Note – commands 231 and 226 can be individual or group or broadcast commands. The low end of the slider by default is 2700 K ( DALI 353) and the top end is 5000K ( DALI 0). These values are normally saved in the fixture. These DALI values can be updated from the DALI Master via memory bank settings, so that standard dimming functions operate at the selected color temperature.

## Tunable White – local selection

Moving the slider with the 0-10v outputs OFF changes the Color temperature. The slider will go from warm (bottom) to cool ( top). Turning the switch On exits CCT mode and the slider controls the brightness again

## Configurable DALI Operation – Motor 0-10v

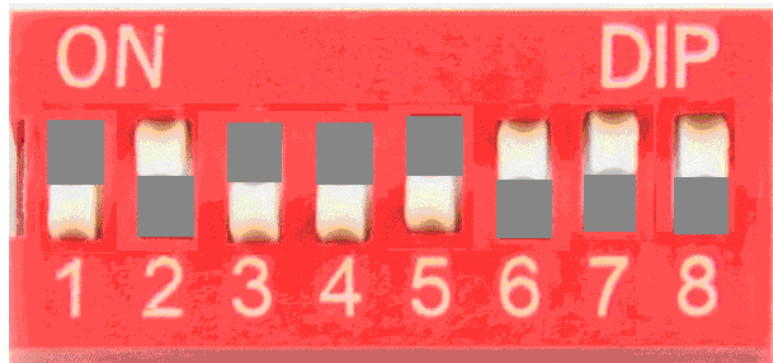

### Set to this setting to enable operation for Motors with 0-10v controls

This setting enables the two outputs of the AL-WS-010v to control a fan. The output A is the fan speed ( 0-10v ) and the output B is the fan direction ( 0v for reverse, 10v for forward ). We re-use the DT8 commands.

This mode allows the AL-WS-010v short address and all other settings to be set via a DALI configuration device – a DALI Master - for example the ATX LED Hub. Until configured – the device will only respond to broadcast commands, and will not transmit DALI packets on switch changes. By default – no short address is defined.

For DALI operation - connect your powered DALI bus to the DA+ and DA- pins ( polarity is not significant ). Our implementation allows multiple masters – we use collision detection to avoid conflicts on the bus.

The device responds to the provisioning commands from a DALI controller. In order for individual, scenes and group addressable functions to work, a ‘short’ address [ 0 thru 63 ] needs to be assigned. This can be done by a DALI Master. Once a short address is assigned – the device can be understood to operate as two devices in one.

- 1) DALI driver – the 0-10v outputs will have a unique DALI short address after provisioning. This address is automatically assigned by the DALI Master – commands from the bus or will set the level of the 0-10v outputs. The 0-10v outputs are connected to the motor for speed and direction.  
The device responses to Group and Scene commands as configured by the Master.
- 2) DALI Dimmer / Switch – before and after a short address is assigned, user actions locally will affect the local 0-10v outputs. After a short address is assigned, it will transmit these levels to the bus. There are two operation modes for this feature:
  - a) Single address – the changes by the user ( On/Off, Dimming ) will be sent to the bus to inform the Hub of the status and level of the lights.
  - b) Group mode – the switch can be set by the Master to operate in Group mode – this will cause the user initiated On/Off/Dimming to be set to the group defined – this allows all DALI devices that are members of this group to receive DALI On/Off and Dimming commands.

See Auto-Grouping instructions below.

The Slider functions to set the speed. Turn the switch on to turn the fan on, and control the speed from the slider. The minimum level will default to about 4 volts – this can be changed by the DALI master

To change direction – turn the fan off, then move the slider to the top for forward, and to the bottom for reverse. Turn the switch on to control speed. Turn the switch off to turn the fan off

From the DALI master – we implemented the forward and reverse feature as “Warm” and “Cool” – this allows the fan to be easily controlled by any existing DALI DT8 ( CCT ) controller.



# Example of Driver Connections

## Carro Ceiling Fan Motor

Connecting a AL-WS-010v to a Carro Fan

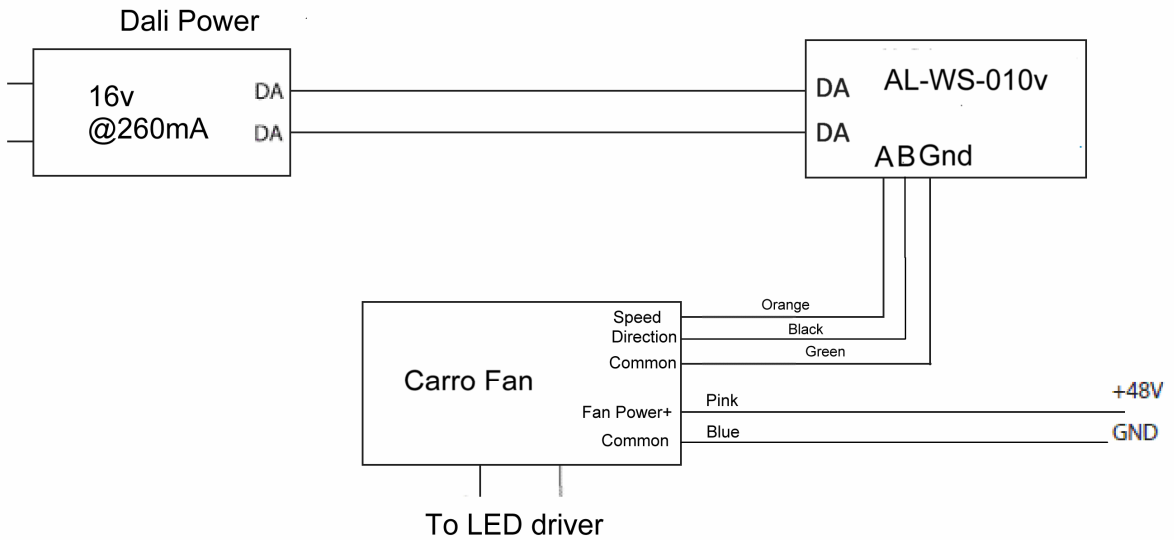

## Meanwell LDD-350H-DA DALI

Connecting a AL-DALI-010v to Meanwell LDD-350H-WDA

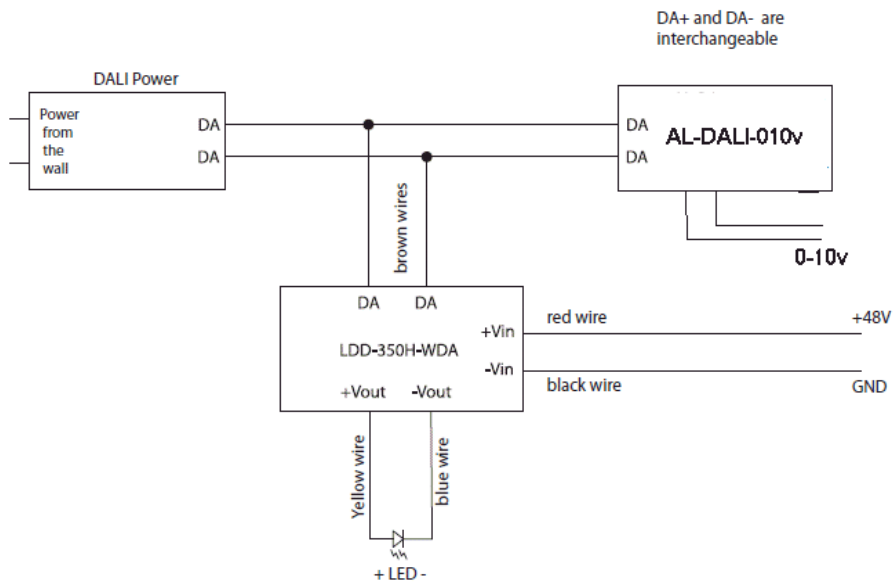

# Example of Driver Connections

## Sunricher SRP-2309-75

Connecting a AL-WS-010v to a DALI driver

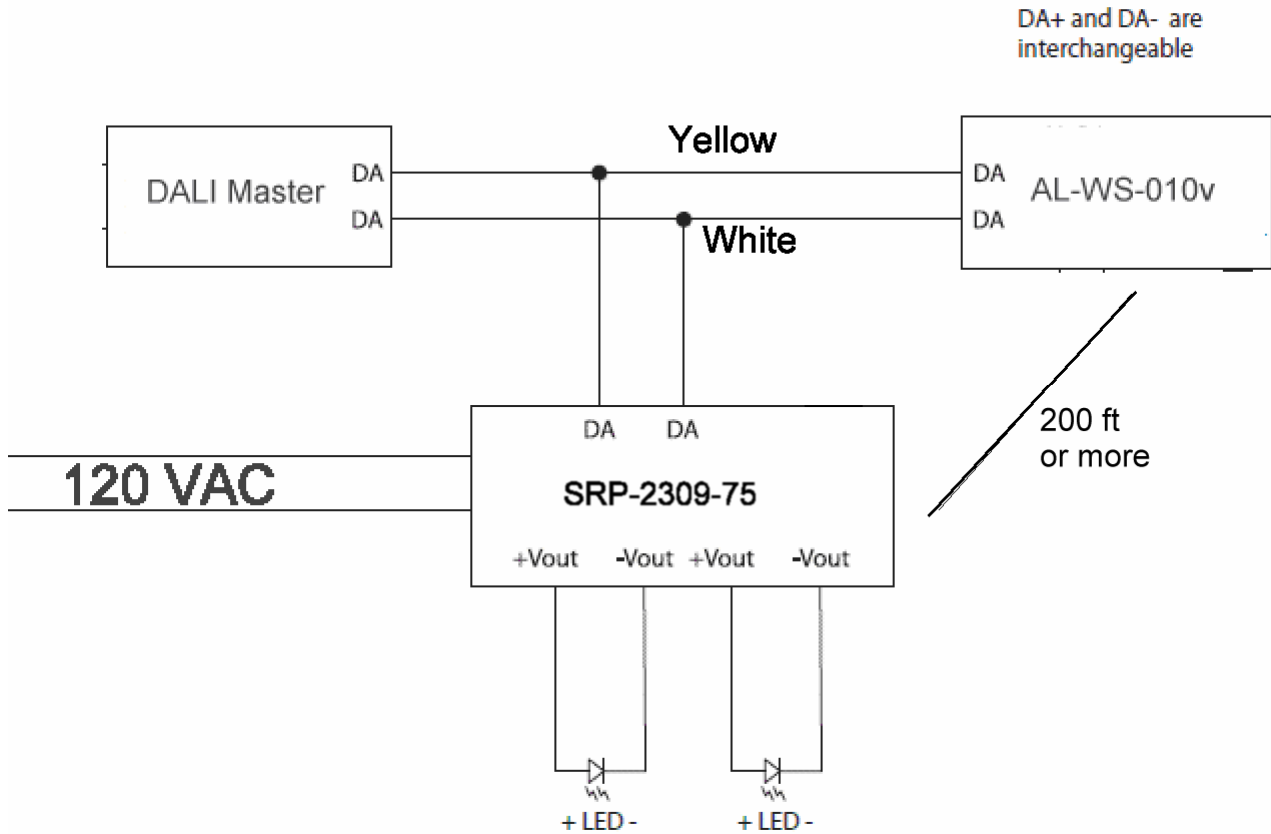

# DALI Commands Supported

Notes: \* = 2x in 100ms, A = ATX LED, C = CCT modes

0	LED Off	
1	UP 8 steps	
2	Down 8 steps	
3	UP one step but don't turn on	
4	Down one step but not off	
5	Set to MAX level	
6	Set to Min level	
7	Down one step and Off if needed	
8	Up one step or on if needed	
32	Reset to defaults ( don't change Short Address)	
33	Save ARC level to DTR	
A 35	Set N-Way mode ( DTR is the value )	See table below
38	Reset switches to mechanical state ( Up = On )	
42	Store DTR as new Max Level,	
43	Store DTR as new Min Level	
44	Store DTR as new system Fail Level	Not used
45	Store DTR as new power up level	
46	Store DTR as Fade Up duration	
47	Store DTR as Fade Down duration	
	FADE times in seconds ( 0-7 )	0, .7, 1.0, 1.4, 2.0, 2.8, 4.0, 5.6 ( 8-15 ) , 8.0, 11.3, 16.0, 22.6, 32.0, 45.2, 64.0, 90.0
49	Set UPS mode, DTR => temporary Maximum	Min-254      Reset with 255
128	Store DTR as short address	
* 129	Enable memory Bank write	
144	Query Status	
bit 0	Left Led Fail ( DR2 )	
bit 1	Right LED Fail ( DR2 )	
bit 2	ARC Level greater than 0	
bit 3	ARC setting out of range	
bit 4	Fade in action	
bit 5	Device not configured after reset	
bit 6	Missing Short Address	
bit 7	No ARC level set after power failure	
145	Query if Short Address matches one stored	
146	Query if either attached LED failed or missing	
147	Query if LED on	
148	Query if ARC command exceeded Min / Max	
149	Query if in Reset state	
150	Query if no address assigned	
151	Query DALI version number ( == 1)	
152	Query DTR	
153	Query LED type ( return 6 normally, or 8 if CCT mode enabled	
154	Query Physical DIM level ( See DR2 info)	
155	Query Power Failure	
156	Query DTR 1	
157	Query DTR 2	
A 158	Query N-Way mode	
160	Query Actual Dim Level	

## DALI Commands Supported

	161	Query Max Level	
	162	Query Min Level	
	163	Query Power On Dim Level	
	164	Query System Fail Level	
	165	Query Fade Rate value	
A	166	Query HW Type ( 2 = 0-10v, 1 = DR2)	
	171	Query presence of 0-10v in transceiver mode = response == 0xA5	
	192	Query group association 0-7	
	193	Query group association 8-15	
	194	Query Random High bits	
	195	Query Random Middle bits	
	196	Query Random Low bits	
	197	Query Memory Bank address DTR1:DTR	
C	226	Save CCT setting	
C	231	Set CCT color ( value from DTR )	
C	232	Step CCT Cooler	
C	233	Step CCT Warmer	
C	250	Query Color	
	255	Test CCT mode	Response is 209

Global Commands – processed by all DALI devices on the bus

			Hex
	256	Terminate	A1
	257	Set DTR	A3
*	258	Initial Addressing Mode	A5
	259	Randomize	A7
	260	Compare Random Address	A9
	261	Withdraw from Random Addressing	AB
	264	Set High Byte	B1
	265	Set Middle Byte	B3
	266	Set Low Byte	B5
	267	Set Short Address if match	B7
	268	Query Short Address	B9
	269	Query Long Address Match	BB
	272	If value == 8, enable CCT mode	C1
	273	Set DTR1	C3
	274	Set DTR2	C5
	275	Write Data at Memory Bank DTR1:DTR	Send confirm C7
	276	Write Data at Memory Bank DTR1:DTR	no response C9

## Memory Bank 0

Address	Fw version	Bank 0 Name	Bank 0 Value
0		Bytes per Bank ( minus 1)	63
1		Checksum	calculated
2		Number of Banks ( minus 1)	3
3		UPC code – msb	722512407282
4		UPC code	
5		UPC code	
6		UPC code	
7		UPC code	
8		UPC code – lsb	
9		FW Version	
10		HW Version	
11		Serial Number – msb	Assigned by Master
12		Serial Number	
13		Serial Number	
14		Serial Number – lsb	
15	43	N-Way Mode	0 = normal, 1 = 2 <sup>nd</sup> Short Add
16	43	N-Way Short Address	255
17		0-10v Minimum Dimming Voltage ( off is always 0 volts)	Default: 25 = 1.0v
18		0-10v Maximum Voltage	Default: 254 = 10 volts
19		DALI value for cool divided by 2	Default is 0
20		DALI value for warm divided by 2	Default is 176 ( 354 )
21	43	Group used to send switch changes 255 or 0-15	Default is 255 ( send short address)

## Memory Bank 1-3

Address	Name	Value
0	Bytes per Bank ( minus 1)	63
1	Checksum	Calculated
2	Number of Banks ( minus 1)	3
3-63	User Storage	

## Memory Bank 4 (read only)

Address	Name	Value
3	Up Time	Hours / 256
4	Up Time	Hours (8 years max)
5	On Time	Hours / 256
6	On Time	Hours (8 years max)
11	Read back switch	-

## System Configuration and Debug Tools

Version 31 and later firmware supports these debug operations: Note – these are broadcast commands, so every device on the bus will be programmed to these settings. Use with care.

Mode 253 Pulse mode: ( 1011 1111 )

Setting the DIP switches to 253 enables pulse mode. The lights will all be set to Warm, then Cool, then off, each 2 seconds. The cycle will stop if the switch is turned off – it can be stopped in Warm, Cool or Off. FW 42 or later.

Mode 252 Local 0-10v outputs - Minimum dim setting ( 0011 1111 )

Setting the DIP switches to 252 ( all on, #1 and #2 off ) enables physical minimum dim mode of this switch. Turn the Rocker off. When the rocker switch turned from OFF to ON, moving the slider will adjust the physical minimum dim level, this value will be stored into device memory when you turn the slider OFF. When off, change the DIP switch settings to the operational mode needed.

Mode 251 set Minimum dim setting of ALL remote devices 1101 1111 ( contact factory )

Setting the DIP switches to 251 ( all on, #3 off ) enables setting the minimum dim value. After turning the rocker switch from Off to On, moving the slider will adjust the Minimum dim level of ALL connected DALI devices on the bus, these values will be stored into device memory of every device on the bus. Take note! Turn the slider OFF when done, then change the DIP switch settings. Disconnect any device that should not be programmed!

Mode 249 set Power On/Fail level of ALL remote devices 1001 1111 ( contact factory )

Setting the DIP switches to 249 ( all on, #2 and #3 off ) enables setting Power / Fail values. Turning the rocker switch from Off to On, the slider will adjust the Fail and Power On dim level of ALL connected DALI devices on the bus, these values will be stored into device memory of every device on the bus. Take note!. Turn the slider OFF when done, then change the DIP switch settings.

## Power Up ID

If the AL-WS-010v is not in managed mode – then the first time a switch is flipped, 2 DALI packets will be output. These 2 bytes sent with global command 0xC3 – this loads the DTR2 register – and informs a bus master or logger of the hardware and firmware version