

60W multi-current with dip switch ELV/Triac Dimmable CC LED driver

(Multi-output current with DIP switch adjustable) (10W,20W,40W,60W available)

■ Features:

- Output constant current
- Range AC input :100-277VAC
- Efficiency up to 80%
- Built-in active PFC function
- Protections: short circuit/over current/over load
- Full protection plastic housing easy installation
- IP20 design for indoor installation/in dry&damp location
- Cooling by free air convection
- Dimming function: Triac/phase cut dimming
Work with leading or trailing edge Triac dimmer
(ON key: leading edge; 1 key: trailing edge)
- Strong compatibility, flicker-free dimming
- Suitable for LED lighting and moving sign applications
- UL Listed Class 2, Class P
- 7 years warranty



Specification:



Model		SMT-M-060CT															
Output	Rated current (A)	0.6	0.7	0.8	0.9	1.0	1.1	1.2	1.3	1.4	1.5	1.6	1.7	1.8	1.9	2.0	2.1
	DIP Code	LLLL		LTLL		LLTL		LTTL		LLLT		LTLT		LLTT		LT TT	
	DIP Code		TLLL		TTLL		T LTL		TTTL		T LLT		TTLT		T LTT		TTTT
	Current Tolerance	±5%															
	DC Voltage (V)	3-65V				3-60	3-55	3-50	3-46	3-43	3-40	3-38	3-35	3-33	3-32	3-30	3-39
	Rated power (W)	39	45.5	52	58.5	60											
Input	Rated Input Voltage	110-277VAC															
	Rated Frequency	47-63HZ															
	Power Factor	Full loading ≥0.96@110VAC; ≥0.98@277VAC;															
	Efficiency (Typ.)	Full loading ≥81%@110VAC; ≥84%@277VAC;															
	AC Current (Max.)	0.45A															
	Inrush Current (Typ.)	30.4A, 37us @ 50% Ipeak at 110-277VAC															
	Leakage current	<0.50mA															
Protection	Short Circuit	Constant current mode, recovers automatically after fault condition is removed															
	Over load	Hiccup mode, recovers automatically after fault condition is removed															
	Output No-Load Voltage	75V max.															
	Over temperature	Ambient temp. over 50±5°C, output current will be reduced to 50%;															

		Ambient temp. over 60±5°C, output will be off; recovers automatically after temp. drops.
	Protection Class:	II
Environment	Working TEMP.	-30-+60°C
	Working Humidity	20-90%RH, non-condensing
	Storage TEMP. Humidity	-30-+80°C, 10-95%RH
	TEMP. coefficient	±0.03%/°C (0-50°C)
	Vibration	10-500Hz, 2G 10min./1 cycle, period for 60min. each along X,Y,Z axes
Safety	Safety standards	EN61347-1 EN61347-2-13 UL8750
	Withstand voltage	I/P-O/P:3.75KVAC
	Isolation resistance	I/P-O/P:100MΩ/500VDC/25°C/70%RH
Others	Weight	0.30Kg
	Size	192.5x62x24mm(L*W*H)
	packing	290*215*140mm (20PCS/CTN)
Notes	1. All parameters NOT specially mentioned are measured at 110V,277VAC input, rated load and 25°C of ambient temperature. 2. Tolerance: includes set up tolerance, line regulation and load regulation.	

■ Mechanical Specification:

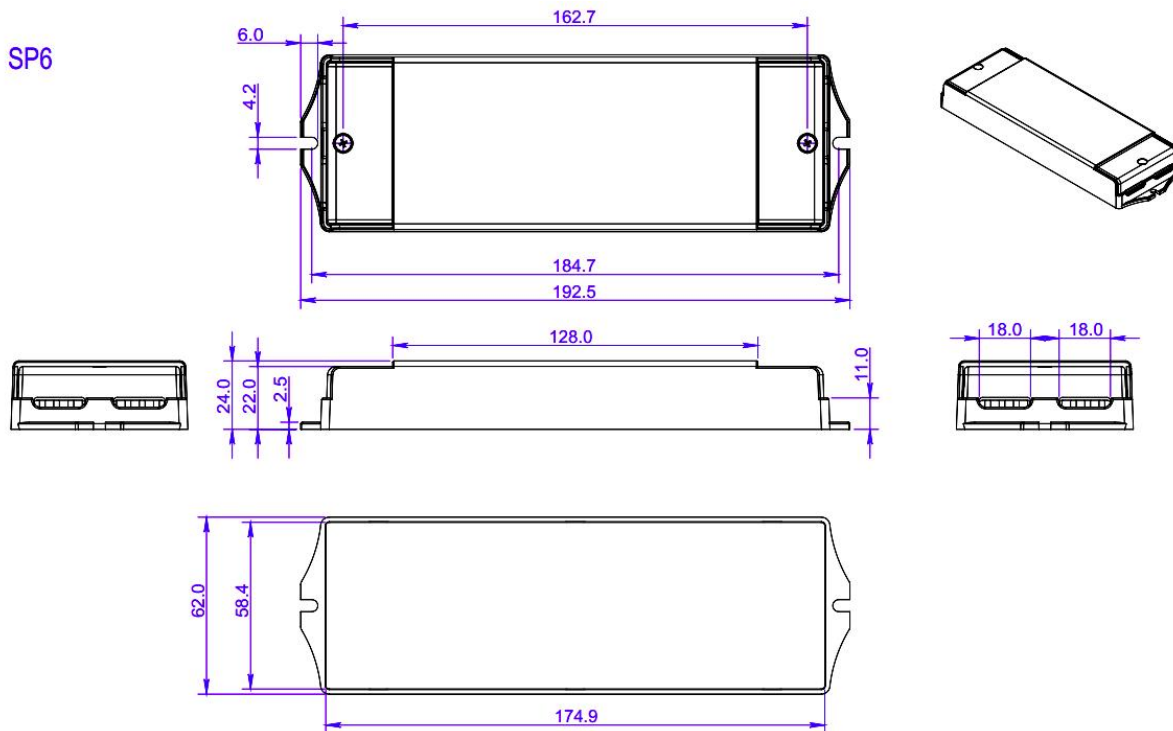

- Input with DG126 terminals 3P: Live Wire AC (L), Neutral Wire AC(N)
- Output LED SEC with DG126 terminals 2P: output Positive (LED+), output negative (LED-). Connected to LED Lamps.
- Suggested wire diameter: Input 0.75-2mm²; Output:0.5-2mm².

Note: Please make sure you connect these correctly otherwise your product will not function correctly and could be damaged

■ Derating Curve

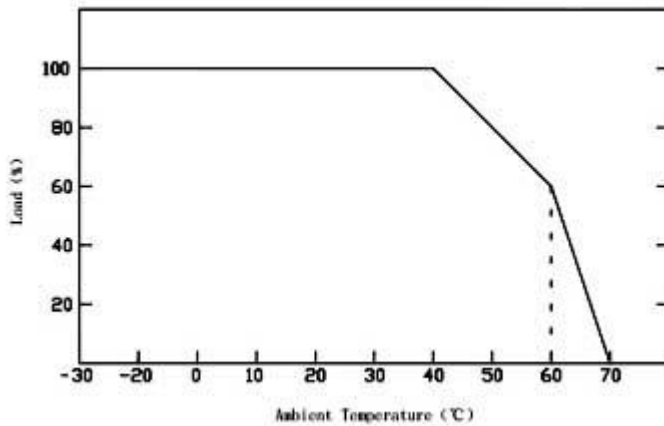

- To extend their life, please refer to the Derating Curve and derate according to the temperature.

■ Dimming Operation

- Output constant current level can be adjusted through input terminal of the AC phase line(L) by connection a Triac dimmer.
- Usually matching with leading edge and trailing edge dimmer both.

At the input area, you will find dip switch on the terminal.

ON key for leading edge; 1 key for trailing edge. (see right picture)



- please try to use the small power dimmer, have access to a wider dimming range, high-power dimmer is difficult to achieve the output current to zero
- please try to use dimmers with power at least 2 times as the output power of the driver.

■ Connecting Diagram in Single (I)

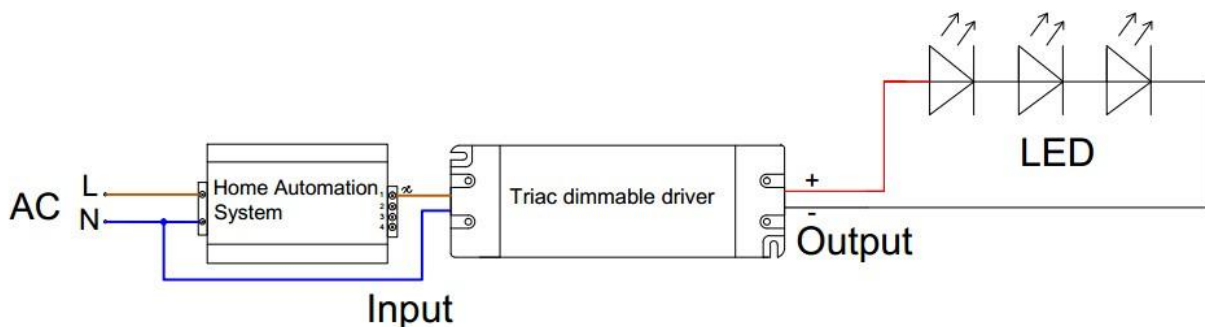
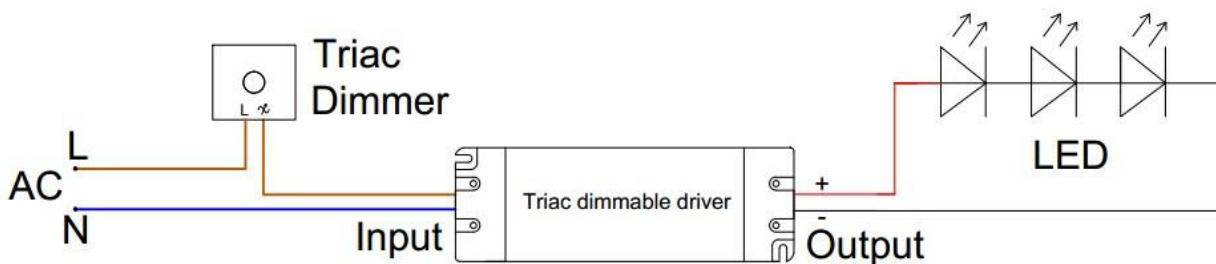

■ Connecting Diagram Multiple (II)

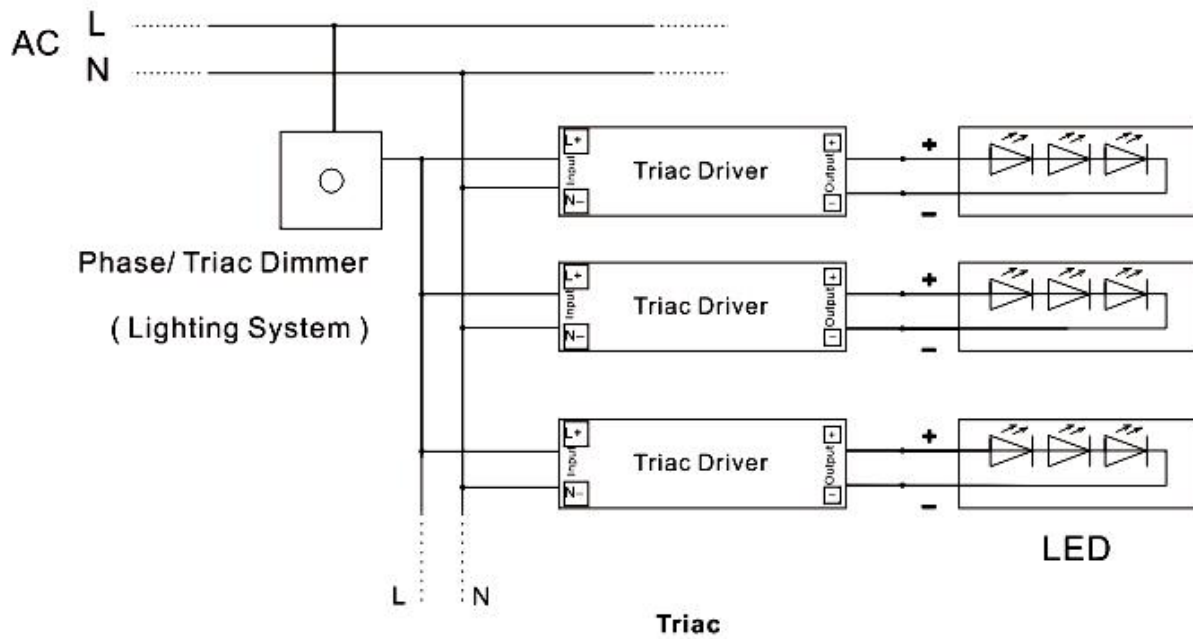

■ Instruction:

- This driver should be installed by qualified and professional person;
- Please make sure the driver is installed with adequate ventilation around it to allow for heat dissipation.
- Ensure that wiring is correct before test in order to avoid light and power supply damage;