

## 5 Channels 125mA x1/x1.5/x2 Charge Pump White LED Driver

### General Description

The RT9385B is a 5 channel WLED driver with auto mode selection of x1, x1.5 and x2 mode with low dropout voltage in current sources. The RT9385B can power up to 5 white LEDs with regulated constant current for uniform intensity. Each channel (LED1 to LED5) can support up to 25mA. The part maintains highest efficiency by utilizing x1/x1.5/x2 fractional charge pump and low dropout current regulators. An internal 5-bit DAC is used for brightness control. Users can easily configure up to 32 steps of LED current by enable pin.

The RT9385B is available in a WQFN-16L 2x3 package. Small 1µF capacitors can be used for fly capacitors. It provides the best backlighting solution with high efficiency and smallest board space for portable application.

### Ordering Information

RT9385B □ □

- Package Type  
QW : WQFN-16L 2x3 (W-Type)
- Lead Plating System  
G : Green (Halogen Free and Pb Free)

Note :

Richtek products are :

- ▶ RoHS compliant and compatible with the current requirements of IPC/JEDEC J-STD-020.
- ▶ Suitable for use in SnPb or Pb-free soldering processes.

### Marking Information

For marking information, contact our sales representative directly or through a Richtek distributor located in your area.

### Features

- 85% Average Efficiency Over Li-ion Battery Discharge
- Support Up to 5 White LEDs
- Support Up to 25mA/Per Channel
- Support Up to 125mA Output Current
- Flexible 32 Step Brightness Control
- 60mV Current Source Dropout
- 1% LED Current Accuracy
- 0.7% LED Current Matching
- Automatic x1/x1.5/x2 Charge Pump Mode Transition
- Low Input Noise and EMI Charge Pump
- 5V Over Voltage Protection
- Power On/Mode Transition Inrush Protection
- 1MHz Frequency Oscillator
- 0.4µA Low Shutdown Current
- RoHS Compliant and Halogen Free

### Applications

- Camera Phone, Smart Phone
- White LED Backlighting

### Pin Configurations

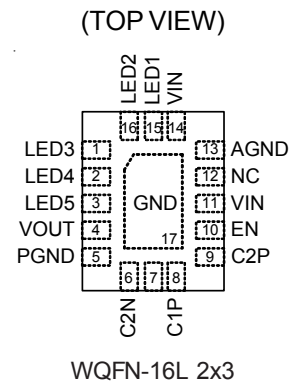

Typical Application Circuit

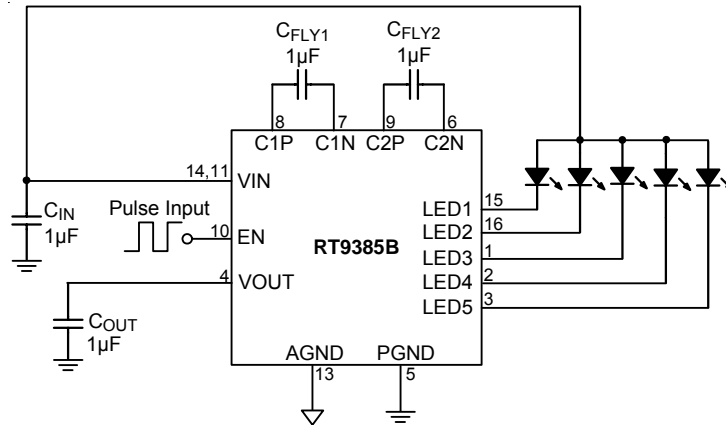

Functional Pin Description

Pin No.	Pin Name	Pin Function
1	LED3	Current Sink for LED3. (If not in use, this pin should be connected to VIN)
2	LED4	Current Sink for LED4. (If not in use, this pin should be connected to VIN)
3	LED5	Current Sink for LED5. (If not in use, this pin should be connected to VIN)
4	VOUT	Charge Pump Output.
5	PGND	Ground.
6	C2N	Fly Capacitor 2 Negative Connection.
7	C1N	Fly Capacitor 1 Negative Connection.
8	C1P	Fly Capacitor 1 Positive Connection.
9	C2P	Fly Capacitor 2 Positive Connection.
10	EN	Chip Enable (Active High).
11, 14	VIN	Power Input.
12	NC	No Internal Connection.
13	AGND	Ground.
15	LED1	Current Sink for LED1. (If not in use, this pin should be connected to VIN)
16	LED2	Current Sink for LED2. (If not in use, this pin should be connected to VIN)
17 (Exposed Pad)	GND	The exposed pad must be soldered to a large PCB and connected to GND for maximum power dissipation.

**Function Block Diagram**

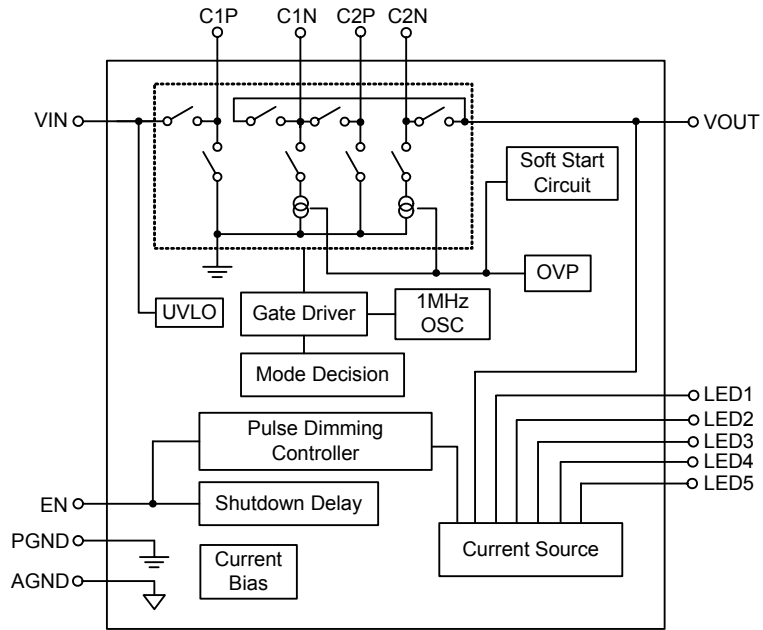

## Absolute Maximum Ratings (Note 1)

- Supply Input Voltage,  $V_{IN}$  ----- -0.3V to 5V
- Power Dissipation,  $P_D @ T_A = 25^\circ C$   
 WQFN-16L 2x3 ----- 1.111W
- Package Thermal Resistance (Note 2)  
 WQFN-16L 2x3,  $\theta_{JA}$  ----- 90°C/W  
 WQFN-16L 2x3,  $\theta_{JC}$  ----- 15°C/W
- Junction Temperature ----- 150°C
- Lead Temperature (Soldering, 10 sec.) ----- 260°C
- Storage Temperature Range ----- -65°C to 150°C
- ESD Susceptibility (Note 3)  
 HBM (Human Body Mode) ----- 2kV  
 MM (Machine Mode) ----- 200V

## Recommended Operating Conditions (Note 4)

- Junction Temperature Range ----- -40°C to 125°C
- Ambient Temperature Range ----- -40°C to 85°C

## Electrical Characteristics

( $V_{IN} = 3.6V$ ,  $V_F = 3.5V$ ,  $C_{IN} = C_{OUT} = 1\mu F$ ,  $C_{FLY1} = C_{FLY2} = 1\mu F$ ,  $I_{LED1 \text{ to } LED5} = 25mA$ ,  $T_A = 25^\circ C$ , unless otherwise specified)

Parameter	Symbol	Test Conditions	Min	Typ	Max	Units
<b>Input Power Supply</b>						
Input Supply Voltage	$V_{IN}$		2.8	--	4.5	V
Under-Voltage Lockout Threshold	$V_{UVLO}$	$V_{IN}$ Rising	1.8	2	2.5	V
Under-Voltage Lockout Hysteresis	$\Delta V_{UVLO}$		--	100	--	mV
Quiescent Current	$I_Q$	x1 Mode	--	1	2	mA
Shutdown Current	$I_{SHDN}$	$V_{IN} = 4.5V$	--	0.4	2	$\mu A$
<b>LED Current</b>						
LED Current Accuracy	$I_{LEDx}$	$I_{LEDx} = 25mA$	-5	0	+5	%
Current Matching		$I_{LEDx} = 25mA$	-2	0	+2	%
<b>Charge Pump</b>						
Oscillator Frequency	$f_{OSC}$		--	1000	--	kHz
<b>Mode Decision</b>						
x1 Mode to x1.5 Mode Transition Voltage ( $V_{IN}$ Falling)		$I_{OUT} = 125mA$ , $I_{LEDx} = 25mA$	--	3.65	3.8	V
Mode Transition Hysteresis		$I_{OUT} = 125mA$ , $I_{LEDx} = 25mA$	--	200	--	mV
<b>Protection</b>						
OVP		$V_{IN} - V_{OUT}$	4.5	5	5.5	V

Parameter		Symbol	Test Conditions	Min	Typ	Max	Units
<b>Dimming</b>							
EN Low to Shutdown Delay				3	--	--	ms
EN Low Time for Dimming		T <sub>IL</sub>		0.5	--	500	μs
EN High Time for Dimming		T <sub>IH</sub>		0.5	--	--	μs
En Pull Low Current		I <sub>EN</sub>		--	2	--	μA
EN Threshold	Logic-Low Voltage	V <sub>IL</sub>		--	--	0.2	V
	Logic-High Voltage	V <sub>IH</sub>		1	--	4.5	V
EN Pull Low Current				--	2		μA

**Note 1.** Stresses listed as the above "Absolute Maximum Ratings" may cause permanent damage to the device. These are for stress ratings. Functional operation of the device at these or any other conditions beyond those indicated in the operational sections of the specifications is not implied. Exposure to absolute maximum rating conditions for extended periods may remain possibility to affect device reliability.

**Note 2.**  $\theta_{JA}$  is measured in the natural convection at  $T_A = 25^\circ\text{C}$  on a high effective four layers thermal conductivity test board of JEDEC 51-7 thermal measurement standard. The case point of  $\theta_{JC}$  is on the exposed pad for the package.

**Note 3.** Devices are ESD sensitive. Handling precaution is recommended.

**Note 4.** The device is not guaranteed to function outside its operating conditions.

Typical Operating Characteristics

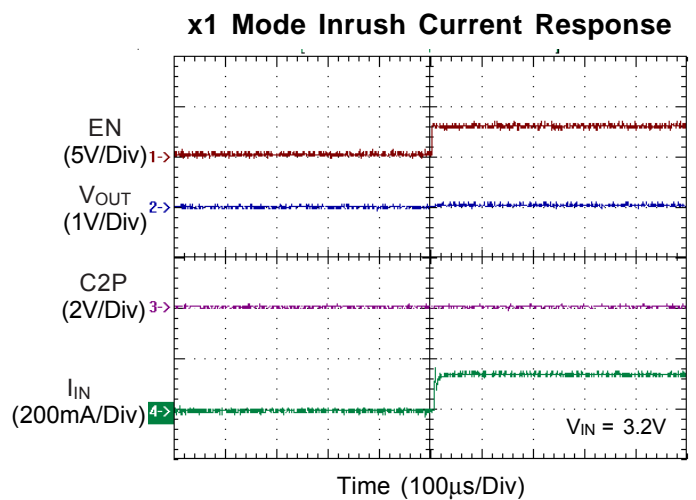
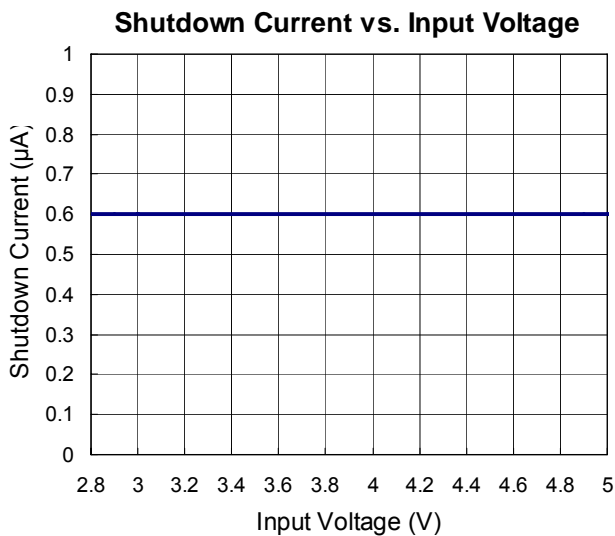
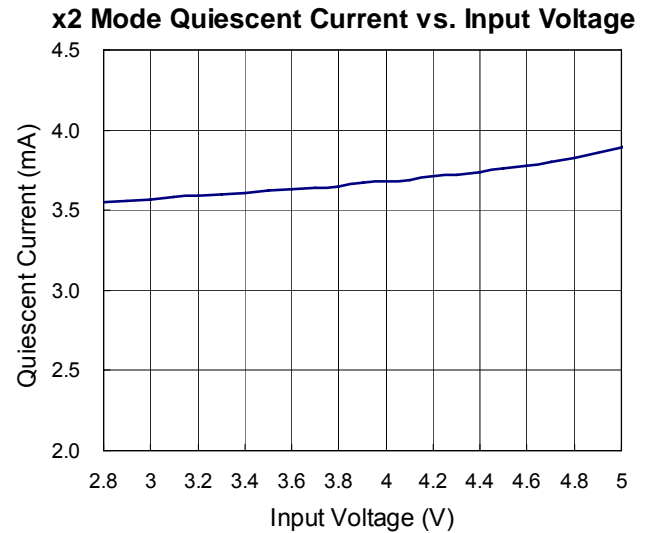
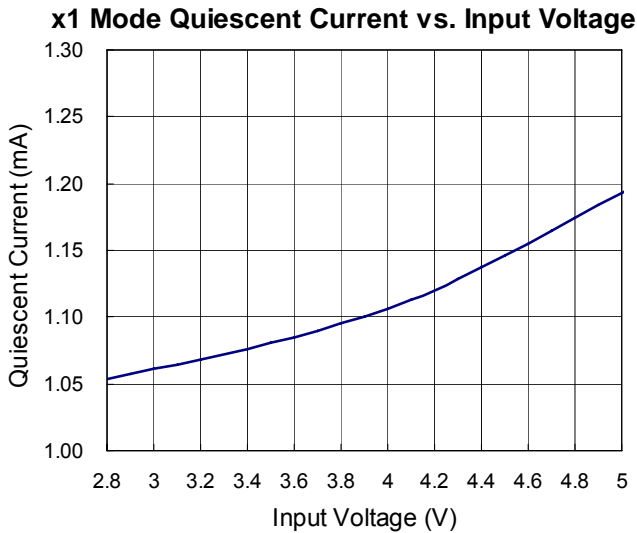
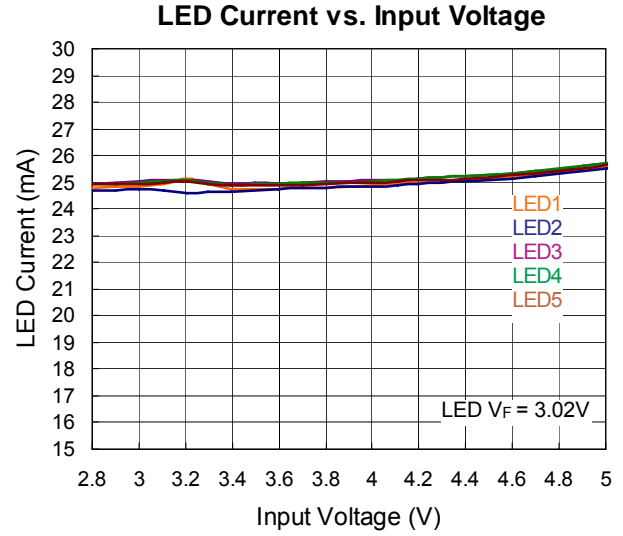
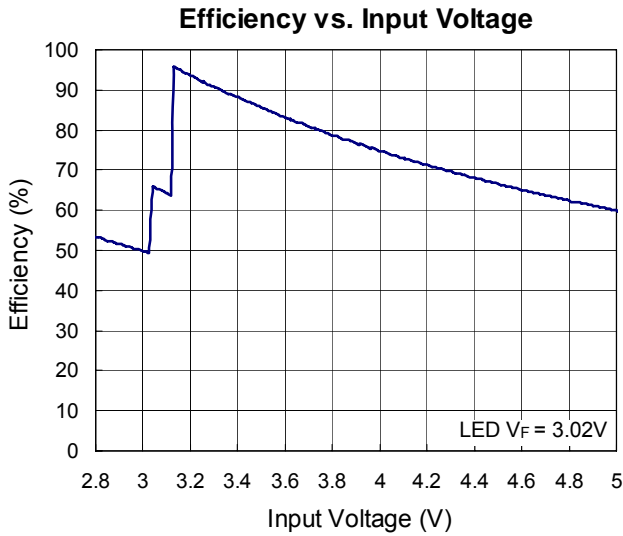

**x1.5 Mode Inrush Current Response**

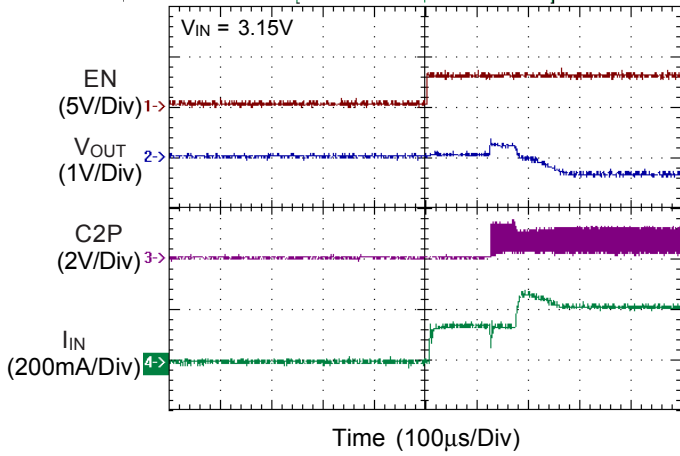

**x2 Mode Inrush Current Response**

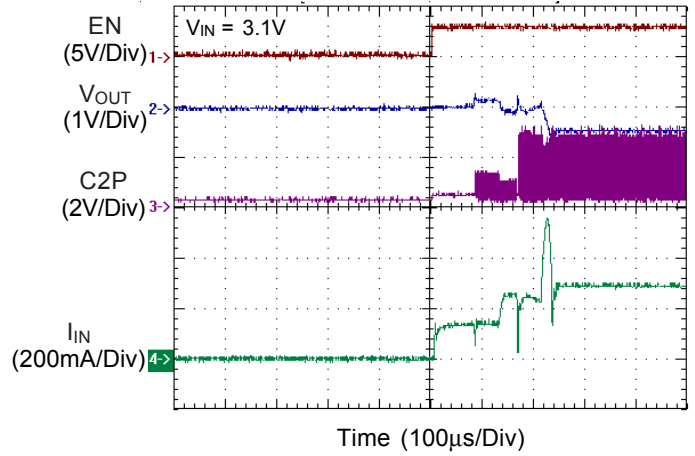

**Pulse Dimming Operation**

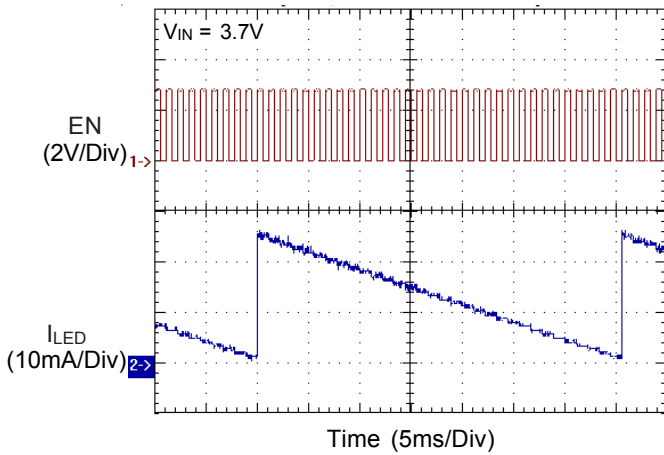

**Ripple & Spike**

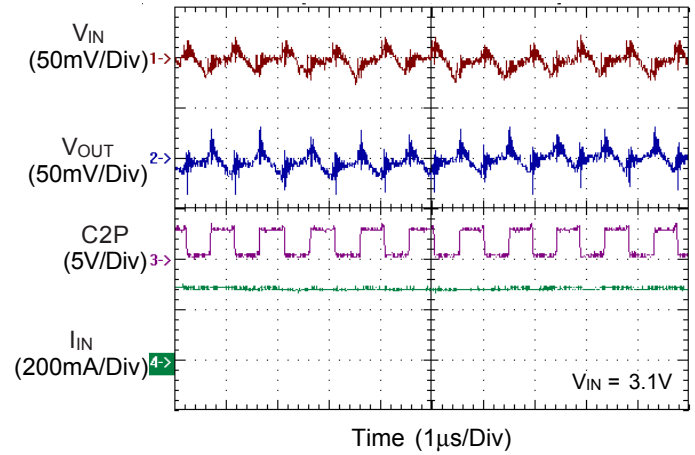

### Applications Information

The RT9385B uses a fractional switched capacitor charge pump to power up to five white LEDs with a programmable current for uniform intensity. The part integrates current sources and automatic mode selection charge pump. It maintains the high efficiency by utilizing an x1/x1.5/x2 fractional charge pump and current sources. The small equivalent x1 mode open loop resistance and ultra-low dropout voltage of current source extend the operating time of x1 mode and optimize the efficiency in white LED applications.

#### Input UVLO

The input operating voltage range of the LED driver is from 2.8V to 4.5V. An input capacitor at the VIN pin could reduce ripple voltage. It is recommended to use a ceramic 1µF or larger capacitance as the input capacitor. The RT9385B provides an under voltage lockout (UVLO) function to prevent it from unstable issue when startup. The UVLO threshold of input rising voltage is set at 2V typically with a hysteresis of 100mV.

#### Soft Start

The charge pump employs a soft start feature to limit the inrush current. The soft-start circuit prevents the excessive inrush current and input voltage droop. The soft-start clamps the input current over a typical period of 50µs.

#### Mode Decision

The RT9385B uses a smart mode selection method to decide the working mode for optimizing the efficiency. Mode decision circuit senses the output and LED voltage for up/down selection. The RT9385B automatically switches to x1.5 or x2 mode whenever the dropout condition is detected from the current source and returns to x1 mode whenever the dropout condition releases.

#### LED connection

The RT9385B supports up to 5 white LEDs. The 5 LEDs are connected from VIN to pin1, 2, 3, 15 and 16 respectively. If the LED is not used, the LED pin should be connected to VIN directly.

### Capacitors Selecting

To get the better performance of the RT9385B, the selection of peripherally appropriate capacitor and value is very important. These capacitors determine some parameters such as input/output ripple voltage, power efficiency and maximum supply current by charge pump. To reduce the input and output ripple effectively, the low ESR ceramic capacitors are recommended. For LED driver applications, the input voltage ripple is more important than output ripple. Input ripple is controlled by input capacitor C<sub>IN</sub>, increasing the value of input capacitance can further reduce the ripple. Practically, the input voltage ripple depends on the power supply impedance. The flying capacitor C<sub>FLY1</sub> and C<sub>FLY2</sub> determine the supply current capability of the charge pump to influence the overall efficiency of the system. The lower value will improve efficiency. However, it will limit the LED's current at low input voltage. For 5x25mA load over the entire input range of 2.8V to 4.5V, it is recommended to use a 1µF ceramic capacitor on the flying capacitor C<sub>FLY1</sub> and C<sub>FLY2</sub>.

### Brightness Control

The RT9385B implements a pulse dimming method to control the brightness of white LEDs. Users can easily configure the LED current by a serial pulse. The dimming of white LEDs' current can be achieved by applying a pulse signal to the EN pin. There are totally 32 steps of current could be set by users. The detail operation of brightness dimming is shown in the Figure 1.

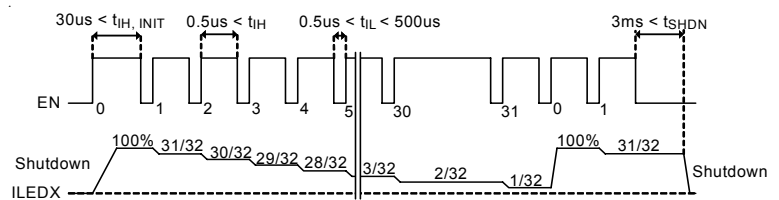

Figure 1. 32 Step Pulse Dimming and Shutdown Delay



**Thermal Considerations**

For continuous operation, do not exceed absolute maximum operation junction temperature. The maximum power dissipation depends on the thermal resistance of IC package, PCB layout, the rate of surroundings airflow and temperature difference between junction to ambient. The maximum power dissipation can be calculated by following formula :

$$P_{D(MAX)} = (T_{J(MAX)} - T_A) / \theta_{JA}$$

Where  $T_{J(MAX)}$  is the maximum operation junction temperature,  $T_A$  is the ambient temperature and the  $\theta_{JA}$  is the junction to ambient thermal resistance.

For recommended operating conditions specification of the RT9385B, The maximum junction temperature is 125°C. The junction to ambient thermal resistance  $\theta_{JA}$  is layout dependent. For WQFN-16L 2x3 package, the thermal resistance  $\theta_{JA}$  is 90°C/W on the standard JEDEC 51-7 four layers thermal test board. The maximum power dissipation at  $T_A = 25^\circ\text{C}$  can be calculated by following formula :

$$P_{D(MAX)} = (125^\circ\text{C} - 25^\circ\text{C}) / (90^\circ\text{C/W}) = 1.111\text{W}$$

for WQFN-16L 2x3 package

The maximum power dissipation depends on operating ambient temperature for fixed  $T_{J(MAX)}$  and thermal resistance  $\theta_{JA}$ . For RT9385B package, the Figure 2 of derating curve allows the designer to see the effect of rising ambient temperature on the maximum power dissipation allowed.

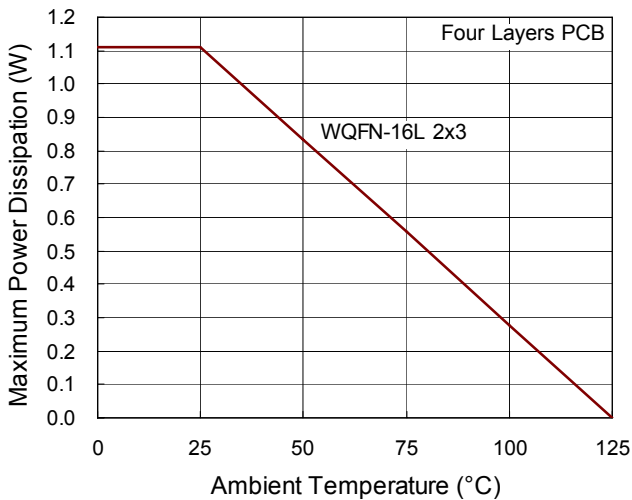

Figure 2. Derating Curve for RT9385B Package

**Layout Considerations**

For best performance of the RT9385B, the following layout guidelines should be strictly followed :

- ▶ Output Capacitor ( $C_{OUT}$ ) should be placed close to  $V_{OUT}$  and connected to ground plane to reduce noise coupling from charge pump to LEDs.
- ▶ All the traces of LED pins running from chip to LED's should be wide and short to reduce the parasitic connection resistance.
- ▶ Input capacitor ( $C_{IN}$ ) should be placed close to  $V_{IN}$  and connected to ground plane. The trace of  $V_{IN}$  in the PCB should be placed far away from the sensitive devices or shielded by the ground.
- ▶ The traces running from pins to flying capacitor should be short and wide to reduce parasitic resistance and prevent noise radiation.

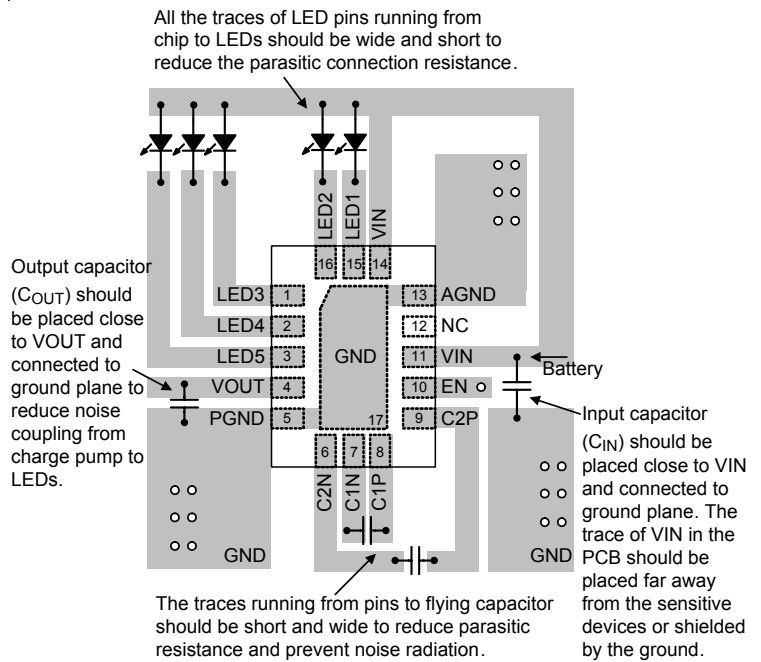
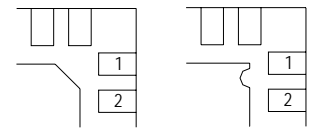
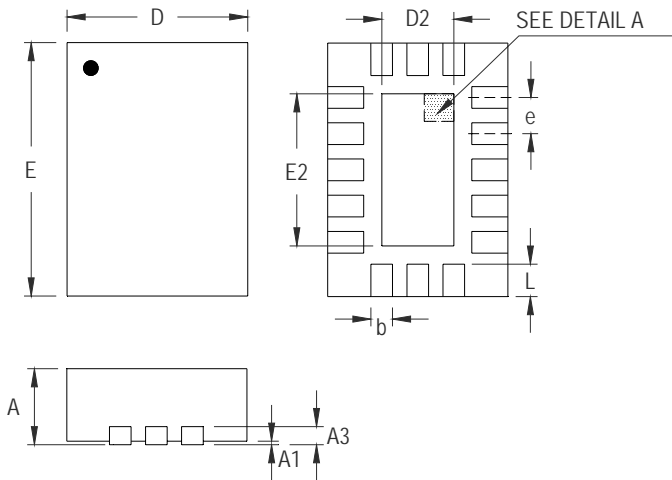

Figure 3. PCB Layout Guide

Outline Dimension



**DETAIL A**

Pin #1 ID and Tie Bar Mark Options

Note : The configuration of the Pin #1 identifier is optional, but must be located within the zone indicated.

Symbol	Dimensions In Millimeters		Dimensions In Inches	
	Min	Max	Min	Max
A	0.700	0.800	0.028	0.031
A1	0.000	0.050	0.000	0.002
A3	0.175	0.250	0.007	0.010
b	0.150	0.250	0.006	0.010
D	1.900	2.100	0.075	0.083
D2	0.700	0.800	0.028	0.031
E	2.900	3.100	0.114	0.122
E2	1.700	1.800	0.067	0.071
e	0.400		0.016	
L	0.325	0.425	0.013	0.017

**W-Type 16L QFN 2x3 Package**

**Richtek Technology Corporation**

14F, No. 8, Tai Yuen 1<sup>st</sup> Street, Chupei City  
 Hsinchu, Taiwan, R.O.C.  
 Tel: (8863)5526789

Richtek products are sold by description only. Richtek reserves the right to change the circuitry and/or specifications without notice at any time. Customers should obtain the latest relevant information and data sheets before placing orders and should verify that such information is current and complete. Richtek cannot assume responsibility for use of any circuitry other than circuitry entirely embodied in a Richtek product. Information furnished by Richtek is believed to be accurate and reliable. However, no responsibility is assumed by Richtek or its subsidiaries for its use; nor for any infringements of patents or other rights of third parties which may result from its use. No license is granted by implication or otherwise under any patent or patent rights of Richtek or its subsidiaries.