

Product Specification

NHD-10.1-1024600BF-ASXP-CTP

TFT Liquid Crystal Display

NHD-	Newhaven Display
10.1-	10.1" Diagonal
1024600-	1024xRGBx600 Pixels
BF-	Model
A-	RGB Interface
S-	High Brightness, White LED Backlight
X-	TFT
P-	IPS, Wide Temperature
CTP-	Capacitive Touch Panel

Table of Contents

Document Revision History.....	2
Mechanical Drawing	3
Pin Description	4
Driver/Controller Information	4
Electrical Characteristics	5
Optical Characteristics	5
Capacitive Touch Panel Registers	6
Timing Characteristics – TFT Display.....	9
Quality Information	11

Additional Resources

- **Support Forum:** <https://support.newhavendisplay.com/hc/en-us/community/topics>
- **GitHub:** <https://github.com/newhavendisplay>
- **Example Code:** <https://support.newhavendisplay.com/hc/en-us/categories/4409527834135-Example-Code/>
- **Knowledge Center:** https://www.newhavendisplay.com/knowledge_center.html
- **Quality Center:** https://www.newhavendisplay.com/quality_center.html
- **Precautions for using LCDs/LCMs:** <https://www.newhavendisplay.com/specs/precautions.pdf>
- **Warranty / Terms & Conditions:** <https://www.newhavendisplay.com/terms.html>



Document Revision History

Revision	Date	Description	Changed By
0	07/22/2022	Initial Release	JT
1	09/08/2022	Updated Operating and Storage Temperature Range, LCD Supply Current, Backlight Enable Voltage, Chromaticity Values, and added Backlight PWM Frequency Range	JT
2	10/12/2022	Updated Product Description in Mechanical Drawing Page, Luminance value and Capacitive Touch Panel Registers	JT
3	09/15/2023	Backlight PWM Frequency Updated from 2000 Hz (Max) to 20,000 Hz (Max)	KL

Mechanical Drawing

Newhaven Display

NHD-10.1-1024600BF-ASXP-CTP
Date Code

Part Label (type/format may vary)

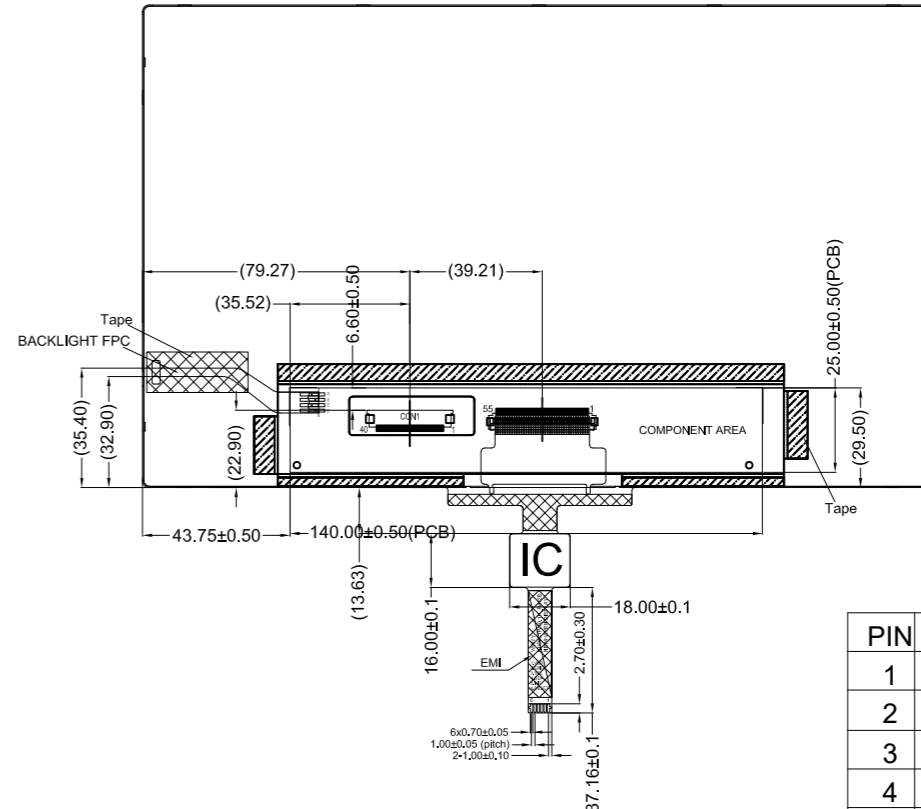
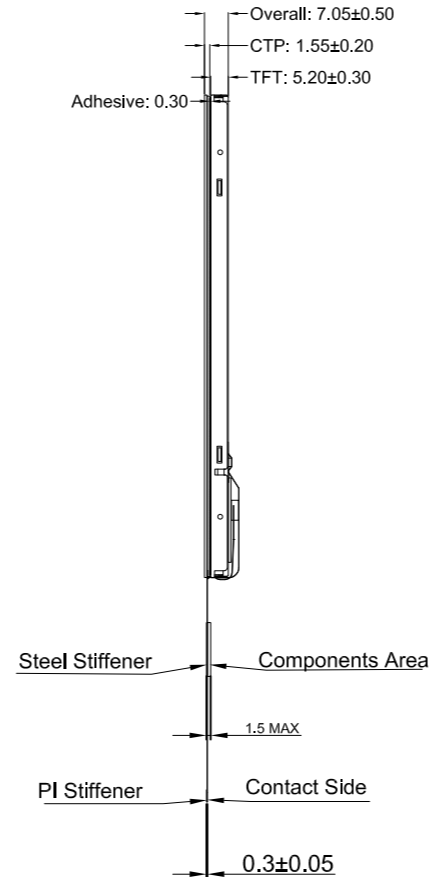
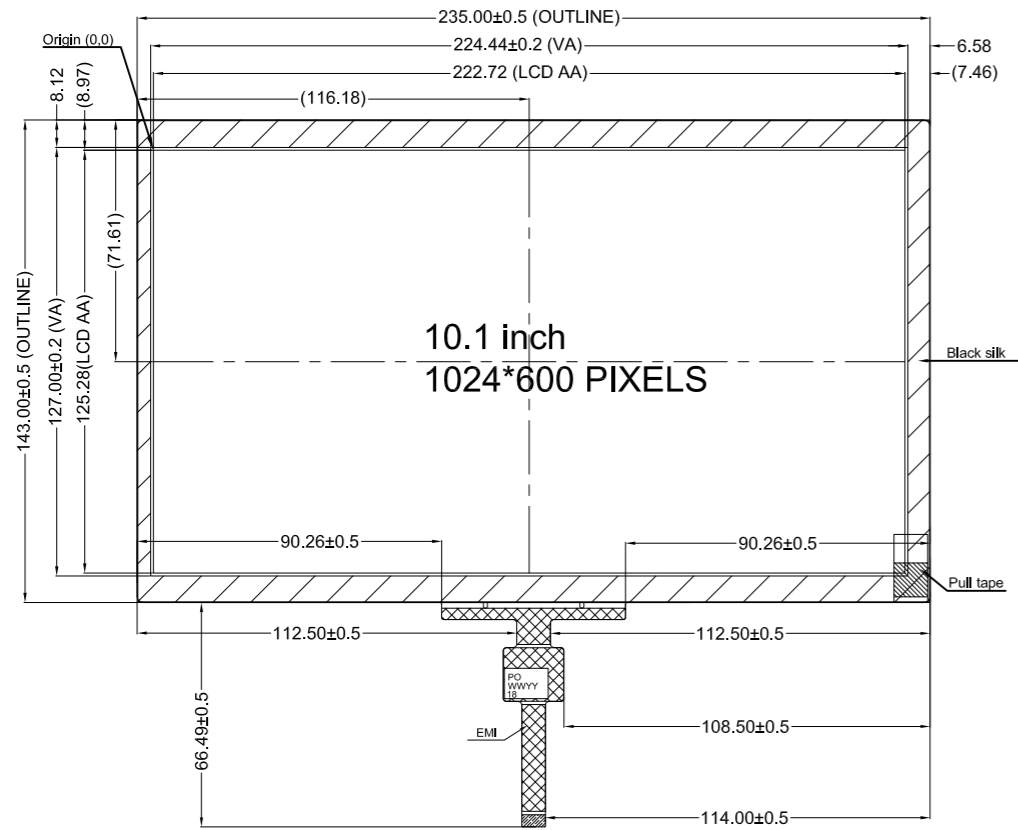

Backlight Circuit

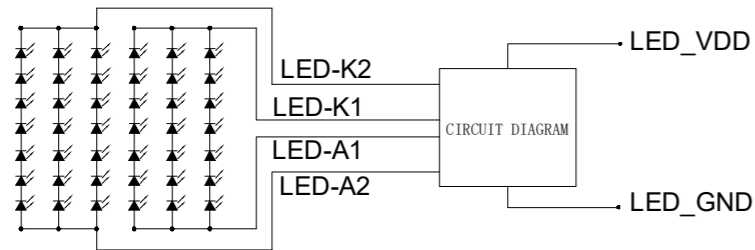

TFT Pinout

PIN	Symbol	PIN	Symb
1	LED-GND	21	G4
2	LED_VDD	22	G5
3	LED_VDD	23	G6
4	LED_VDD	24	G7
5	LED PWM	25	B0
6	LED EN	26	B1
7	GND	27	B2
8	VDD	28	B3
9	R0	29	B4
10	R1	30	B5
11	R2	31	B6
12	R3	32	B7
13	R4	33	GND
14	R5	34	DCLK
15	R6	35	HSD
16	R7	36	VSD
17	G0	37	DEN
18	G1	38	MOD
19	G2	39	RESE
20	G3	40	STBY

CTP Pinout

PIN	SYMBOL
1	VDD
2	GND
3	SCL
4	SDA
5	INT
6	RESET

- Product Description:** 10.1" 1024x600 IPS TFT w/ Capacitive Touch
1. Driver IC: HX8282-A11 TFT, FT5526-003 CTP, MP3398EGF Backlight
 2. Interface: 24-bit RGB TFT, I²C CTP
 3. Power Requirement: 3.3V TFT, 12.0V/360mA Backlight
 4. Optical Features: Normally Black, Transmissive, 700cd/m²
 5. Recommended FFC Connector:
 - TFT: 40pin 0.5mm pitch; Ex. Molex 15020-0435
 - CTP: 6pin 1.0mm pitch; Ex. Molex 52217-0679
 6. Key Features: Built-in EMI Filter, 10-point Multitouch

Standard Tolerance: (Unless otherwise specified) Linear: ±0.3mm		
	Drawing/Part Number: NHD-10.1-1024600BF-ASXP-CTP	Revision: -
Unless otherwise specified: • Dimensions are in Millimeters • Third Angle Projection	Drawn By: K. Lewis	Approved By: K. Lewis
	Drawn Date: 09/15/2023	Approved Date: 09/15/2023
This drawing is solely the property of Newhaven Display International, Inc. The information it contains is not to be disclosed, reproduced or copied in whole or part without written approval from Newhaven Display.		

Pin Description

TFT:

Pin No.	Symbol	Connection	Function Description
1	LED_GND	Power Supply	Ground for Backlight Driver
2-4	LED_VDD	Power Supply	Supply Voltage for Backlight Driver
5	LED_PWM	MPU	Backlight PWM Signal Input (See Table Below)
6	LED_EN	MPU	Backlight Enable H: Backlight On; L: Backlight Off
7	GND	Power Supply	Ground
8	V _{DD}	Power Supply	Supply voltage for LCD (+3.3V)
9-16	[R0-R7]	MPU	Red Data Signals
17-24	[G0-G7]	MPU	Green Data Signals
25-32	[B0-B7]	MPU	Blue Data Signals
33	GND	Power Supply	Ground
34	DCLK	MPU	Dot data Clock
35	HSYNC	MPU	Horizontal sync input
36	VS _{YNC}	MPU	Vertical sync input
37	DEN	MPU	Data Enable signal
38	MODE	MPU	DE/SYNC mode select MODE= H: DE mode MODE= L: SYNC mode
39	RESET	MPU	Active Low Reset Signal
40	STBYB	MPU	Active Low Standby Signal

Recommended LCD connector: 0.5mm pitch 40-Conductor FFC.

Recommended Cable: 40 POS FFC

Molex P/N: 15020-0435

Capacitive Touch Panel:

Pin No.	Symbol	External Connection	Function Description
1	V _{DD}	Power Supply	Supply voltage for Logic (3.3V)
2	V _{SS}	Power Supply	Ground
3	SCL	MPU	Serial I2C Clock (Requires 4.7kΩ pull-up resistor)
4	SDA	MPU	Serial I2C Data (Requires 4.7kΩ pull-up resistor)
5	/INT	MPU	Interrupt signal from touch panel module to host
6	/RESET	MPU	Active LOW Reset signal

Recommended connector: 6pin, 1.0mm pitch, FFC connector. Molex P/N 52271-0679

Driver/Controller Information

TFT:

Source Driver: HX8282-A11 <https://support.newhavendisplay.com/hc/en-us/articles/4414530594583-HX8282-A11>

Gate Driver: HX8696-A01 <https://support.newhavendisplay.com/hc/en-us/articles/4414548297367-HX8696-A>

Backlight Driver: MP3398EGF

Capacitive Touch Panel:

Built-in FT5526EEZ-003 Controller: <https://support.newhavendisplay.com/hc/en-us/articles/4414392845079-FT5x26>



Electrical Characteristics

TFT:

Item	Symbol	Condition	Min.	Typ.	Max.	Unit
Operating Temperature Range	T _{OP}	Absolute Max	-20	-	+70	°C
Storage Temperature Range	T _{ST}	Absolute Max	-30	-	+80	°C
Supply Voltage for LCD	V _{DD}	-	3.0	3.3	3.6	V
Supply Current for LCD	I _{DD}	V _{DD} = 3.3V	96.5	193	240	mA
"H" Level input	V _{IH}	-	0.7 * V _{DD}	-	V _{DD}	V
"L" Level input	V _{IL}	-	GND	-	0.3 * V _{DD}	V
"H" Level output	V _{OH}	-	V _{DD} - 0.4	-	V _{DD}	V
"L" Level output	V _{OL}	-	-	-	GND + 0.4	V
Supply Voltage for Backlight Driver	LED_V _{LED}	-	5.0	12.0	22.4	V
Supply Current for Backlight Driver ¹	LED_I _{LED}	-	160	360	1200	mA
Backlight Lifetime ²	-	T _{OP} = 25°C	30,000	-	-	Hrs.
Backlight Enable Voltage	LED_EN	-	1.5	3.3	5.5	V
Backlight PWM Voltage	LED_PWM	-	1.5	3.3	5.0	V
Backlight PWM Frequency	-	LED_PWM = 3.3V	200	-	20,000	Hz

¹Minimum supply current occurs when supply voltage is at max; maximum supply current when supply voltage is at minimum.

²Backlight lifetime is rated as Hours until **half-brightness**, under normal operating conditions.

Capacitive Touch Panel:

Item	Symbol	Condition	Min.	Typ.	Max.	Unit
Operating Temperature Range	T _{OP}	Absolute Max	-20	-	+70	°C
Storage Temperature Range	T _{ST}	Absolute Max	-30	-	+80	°C
Supply Voltage	V _{DD}	-	3.0	3.3	3.6	V
Supply Current – Operating	I _{DD}	-	8	15	23	mA
"H" Level input	V _{IH}	-	0.7*V _{DD}	-	V _{DD}	V
"L" Level input	V _{IL}	-	V _{SS}	-	0.3*V _{DD}	V
"H" Level output	V _{OH}	-	0.7*V _{DD}	-	V _{DD}	V
"L" Level output	V _{OL}	-	V _{SS}	-	0.3*V _{DD}	V

Optical Characteristics

Item	Symbol	Condition	Min.	Typ.	Max.	Unit	
Optimal Viewing Angles	Top	CR ≥ 10	-	80	-	°	
	Bottom		-	80	-	°	
	Left		-	80	-	°	
	Right		-	80	-	°	
Contrast Ratio	CR	-	600	800	-	-	
Luminance	L _V	-	510	700	850	cd/m ²	
Response Time (Rise + Fall)	T _R + T _F	T _{OP} = 25°C	-	25	35	ms	
Chromaticity	Red	X _R	-	0.57	0.60	0.63	-
		Y _R	-	0.33	0.36	0.39	-
	Green	X _G	-	0.30	0.33	0.36	-
		Y _G	-	0.51	0.54	0.57	-
	Blue	X _B	-	0.10	0.13	0.16	-
		Y _B	-	0.05	0.08	0.11	-
White	X _W	-	0.28	0.31	0.34	-	
	Y _W	-	0.30	0.33	0.36	-	



Capacitive Touch Panel Registers

Register No.	Access	Register Name	Bits	Value	Description
01h	RO	Gesture ID	[7:0]	1Ch	Swipe Up
				14h	Swipe Down
				10h	Swipe Left
				18h	Swipe Right
				48h	Zoom In
				49h	Zoom Out
				00	No gesture
02h	RO	Touch Points	[7:0]	0-Ah	0: No touch detected A: 10 touch points detected
03h	RO	TOUCH1_Event_Flag	[7:6]	0	Put Down
				1	Put Up
				2	Contact
				3	Reserved
03h	RO	TOUCH1_XH	[3:0]	0-1	Upper 4 bits of X touch coordinate
04h	RO	TOUCH1_XL	[7:0]	00 – FFh	Lower 8 bits of X touch coordinate
05h	RO	TOUCH1_YH	[3:0]	0-1	Upper 4 bits of Y touch coordinate
06h	RO	TOUCH1_YL	[7:0]	00 – FFh	Lower 8 bits of Y touch coordinate
07h	RO	TOUCH1_Weight	[7:0]		Touch Weight
08h	RO	TOUCH1_Misc	[3:0]	00-0Fh	Touch Area
09h	RO	TOUCH2_Event_Flag	[7:6]	0	Put Down
				1	Put Up
				2	Contact
				3	Reserved
09h	RO	TOUCH1_XH	[3:0]	0-1	Upper 4 bits of X touch coordinate
0Ah	RO	TOUCH2_XL	[7:0]	00 – FFh	Lower 8 bits of X touch coordinate
0Bh	RO	TOUCH2_YH	[3:0]	0-1	Upper 4 bits of Y touch coordinate
0Ch	RO	TOUCH2_YL	[7:0]	00 – FFh	Lower 8 bits of Y touch coordinate
0Dh	RO	TOUCH2_Weight	[7:0]		Touch Weight
0Eh	RO	TOUCH2_Misc	[3:0]	00-0Fh	Touch Area
0Fh	RO	TOUCH3_Event_Flag	[7:6]	0	Put Down
				1	Put Up
				2	Contact
				3	Reserved
0Fh	RO	TOUCH3_XH	[3:0]	0-1	Upper 4 bits of X touch coordinate
10	RO	TOUCH3_XL	[7:0]	00 – FFh	Lower 8 bits of X touch coordinate
11h	RO	TOUCH3_YH	[3:0]	0-1	Upper 4 bits of Y touch coordinate
12h	RO	TOUCH3_YL	[7:0]	00 – FFh	Lower 8 bits of Y touch coordinate
13h	RO	TOUCH3_Weight	[7:0]		Touch Weight
14h	RO	TOUCH3_Misc	[3:0]	00-0Fh	Touch Area
15h	RO	TOUCH4_Event_Flag	[7:6]	0	Put Down
				1	Put Up
				2	Contact
				3	Reserved
15h	RO	TOUCH4_XH	[3:0]	0-1	Upper 4 bits of X touch coordinate
16h	RO	TOUCH4_XL	[7:0]	00 – FFh	Lower 8 bits of X touch coordinate
17h	RO	TOUCH4_YH	[3:0]	0-1	Upper 4 bits of Y touch coordinate
18h	RO	TOUCH4_YL	[7:0]	00 – FFh	Lower 8 bits of Y touch coordinate
1Ah	RO	TOUCH4_Misc	[3:0]	00-0Fh	Touch Area
1Bh	RO	TOUCH5_Event_Flag	[7:6]	0	Put Down
				1	Put Up
				2	Contact
				3	Reserved



Register No.	Access	Register Name	Bits	Value	Description
1Bh	RO	TOUCH5_XH	[3:0]	0 -1	Upper 4 bits of X touch coordinate
1Ch	RO	TOUCH5_XL	[7:0]	00 – FFh	Lower 8 bits of X touch coordinate
1Dh	RO	TOUCH5_YH	[3:0]	0 -1	Upper 4 bits of Y touch coordinate
1Eh	RO	TOUCH5_YL	[7:0]	00 – FFh	Lower 8 bits of Y touch coordinate
1Fh	RO	TOUCH5_Weight	[7:0]		Touch Weight
20	RO	TOUCH5_Misc	[3:0]	00-0Fh	Touch Area
21h	RO	TOUCH6_Event_Flag	[7:6]	0	Put Down
				1	Put Up
				2	Contact
				3	Reserved
21h	RO	TOUCH6_XH	[3:0]	0 -1	Upper 4 bits of X touch coordinate
22h	RO	TOUCH6_XL	[7:0]	00 – FFh	Lower 8 bits of X touch coordinate
23h	RO	TOUCH6_YH	[3:0]	0 -1	Upper 4 bits of Y touch coordinate
24h	RO	TOUCH6_YL	[7:0]	00 – FFh	Lower 8 bits of Y touch coordinate
25h	RO	TOUCH6_Weight	[7:0]		Touch Weight
26h	RO	TOUCH6_Misc	[3:0]	00-0Fh	Touch Area
27h	RO	TOUCH7_Event_Flag	[7:6]	0	Put Down
				1	Put Up
				2	Contact
				3	Reserved
27h	RO	TOUCH7_XH	[3:0]	0 -1	Upper 4 bits of X touch coordinate
28h	RO	TOUCH7_XL	[7:0]	00 – FFh	Lower 8 bits of X touch coordinate
29h	RO	TOUCH7_YH	[3:0]	0 – 1	Upper 4 bits of Y touch coordinate
2Ah	RO	TOUCH7_YL	[7:0]	00 – FFh	Lower 8 bits of Y touch coordinate
2Bh	RO	TOUCH7_Weight	[7:0]		Touch Weight
2Ch	RO	TOUCH7_Misc	[3:0]	00-0Fh	Touch Area
2Dh	RO	TOUCH8_Event_Flag	[7:6]	0	Put Down
				1	Put Up
				2	Contact
				3	Reserved
2Dh	RO	TOUCH8_XH	[3:0]	0 – 1	Upper 4 bits of X touch coordinate
2Eh	RO	TOUCH8_XL	[7:0]	00 – FFh	Lower 8 bits of X touch coordinate
2Fh	RO	TOUCH8_YH	[3:0]	0 – 1	Upper 4 bits of Y touch coordinate
30	RO	TOUCH8_YL	[7:0]	00 – FFh	Lower 8 bits of Y touch coordinate
31h	RO	TOUCH8_Weight	[7:0]		Touch Weight
32h	RO	TOUCH8_Misc	[3:0]	00-0Fh	Touch Area
33h	RO	TOUCH9_Event_Flag	[7:6]	0	Put Down
				1	Put Up
				2	Contact
				3	Reserved
33h	RO	TOUCH9_XH	[3:0]	0 – 1	Upper 4 bits of X touch coordinate
34h	RO	TOUCH9_XL	[7:0]	00 – FFh	Lower 8 bits of X touch coordinate
35h	RO	TOUCH9_YH	[3:0]	0 – 1	Upper 4 bits of Y touch coordinate
36h	RO	TOUCH9_YL	[7:0]	00 – FFh	Lower 8 bits of Y touch coordinate
37h	RO	TOUCH9_Weight	[7:0]		Touch Weight
38h	RO	TOUCH9_Misc	[3:0]	00 – 0Fh	Touch Area
39h	RO	TOUCH10_Event_Flag	[7:6]	0	Put Down
				1	Put Up
				2	Contact
				3	Reserved
39h	RO	TOUCH10_XH	[3:0]	0 – 1	Upper 4 bits of X touch coordinate
3Ah	RO	TOUCH10_XL	[7:0]	00 – FFh	Lower 8 bits of X touch coordinate
3Bh	RO	TOUCH10_YH	[3:0]	0 – 1	Upper 4 bits of Y touch coordinate
3Ch	RO	TOUCH10_YL	[7:0]	00 - FFh	Lower 8 bits of Y touch coordinate



Register No.	Access	Register Name	Bits	Value	Description
3Dh	RO	TOUCH10_Weight	[7:0]	00-FFh	Touch Weight
3Eh	RO	TOUCH10_Misc	[3:0]	00-0Fh	Touch Area
A1h	RO	ID_G_LIB_VERSION_H	[7:0]	00-FFh	App library version high-byte Default: 0
A2h	RO	ID_G_LIB_VERSION_L	[7:0]	00-FFh	App library version low-byte Default: 2h
A3h	RO	ID_G_CHIPER_HIGH	[7:0]	00-FFh	Chip Vendor ID Default: 0x54
A6h	RO	ID_G_FIRMID	[7:0]	00-FFh	Firmware ID Number Default: 18
A8h	RO	ID_G_VENODRID	[7:0]	00-FFh	CTPM Vendor's Chip ID Default: 79h

Timing Characteristics – TFT Display

DE Mode

Parameter	Symbol	Spec			Unit
		Min.	Typ.	Max.	
DCLK Frequency	fclk	40.8	51.2	67.2	MHz
Horizontal Display Area	thd	1024			DCLK
HSD Period	th	1114	1344	1400	DCLK
HSD Blanking	thb+ thfp	90	320	376	DCLK
Vertical Display Area	tvd	600			TH
VSD Period	tv	610	635	800	TH
VSD Blanking	tvbp+ tvfp	10	35	200	TH

Horizontal Timing

Parameter	Symbol	Spec			Unit
		Min.	Typ.	Max.	
DCLK Frequency	fclk	44.9	51.2	63	MHz
Horizontal Display Area	thd	1024			DCLK
HSD Period	th	1200	1344	1400	DCLK
HSD Pulse Width	thpw	1	-	140	DCLK
HSD Back Porch	thbp	160			DCLK
HSD Front Porch	thfp	16	160	216	DCLK

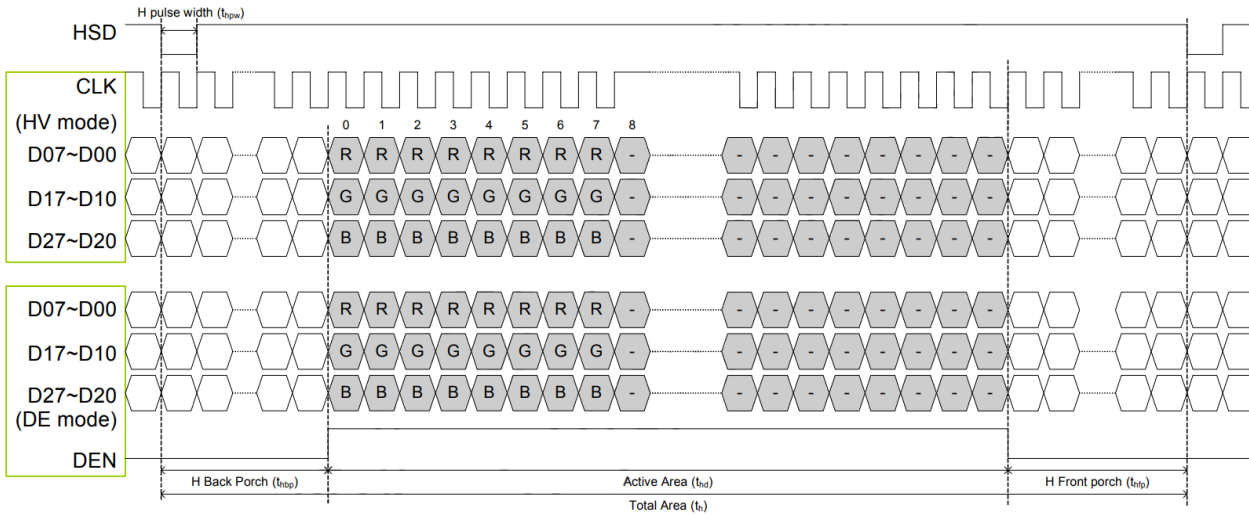

Vertical Timing

Parameter	Symbol	Spec			Unit
		Min.	Typ.	Max.	
Vertical Display Area	tvd	600			TH
VSD Period	tv	624	635	750	TH
VSD Pulse Width	tpw	1	-	20	TH
VSD Back Porch	tvbp	23			TH
VSD Front Porch	tvfp	1	12	127	TH

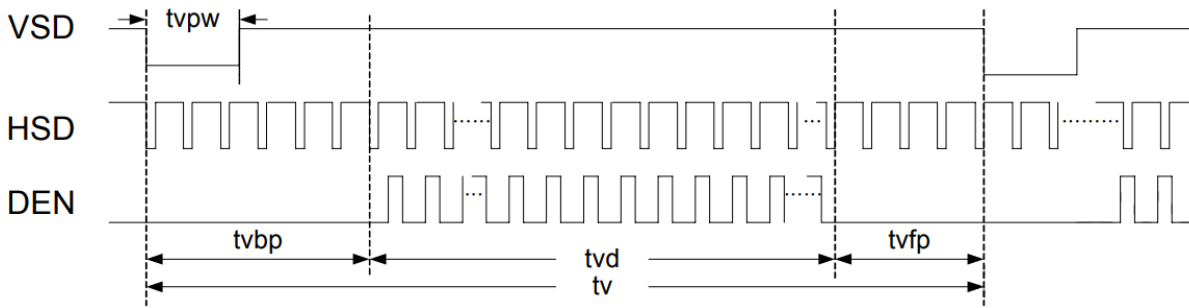

Quality Information

Test Item	Content of Test	Test Condition	Note
High Temperature storage	Endurance test applying the high storage temperature for a long time.	+80°C, 240 hrs.	2
Low Temperature storage	Endurance test applying the low storage temperature for a long time.	-30°C, 240 hrs.	1,2
High Temperature Operation	Endurance test applying the electric stress (voltage & current) and the high thermal stress for a long time.	+70°C, 120 hrs.	2
Low Temperature Operation	Endurance test applying the electric stress (voltage & current) and the low thermal stress for a long time.	-20°C, 120 hrs.	1,2
High Temperature / Humidity Storage	Endurance test applying the electric stress (voltage & current) and the high thermal with high humidity stress for a long time.	+50°C, 90% RH, 120 hrs.	1,2
Thermal Shock resistance	Endurance test applying the electric stress (voltage & current) during a cycle of low and high thermal stress.	-30°C, 30min->25°C, 10min -> 80°C, 30min 10 cycles	
Vibration test	Endurance test applying vibration to simulate transportation and use.	Frequency:250r/min Amplitude: 1 inch Time:45min	3
Static electricity test	Endurance test applying electric static discharge.	Air: V _s =8KV, Contact: V _s =4KV 10 Times	

Note 1: No condensation to be observed.

Note 2: Conducted after 4 hours of storage at 25°C, 0%RH.

Note 3: Test performed on product itself, not inside a container.