



FOCUS LCDs

LCDs MADE SIMPLE®

Ph. 480-503-4295 | NOPP@FocusLCDs.com

TFT | OLED | CHARACTER | GRAPHIC | UWVD | SEGMENT | CUSTOM

TFT Display Module

Part Number

E50RE-I-RS650-N

Overview:

- 5.0-inch TFT (120.70x75.90mm)
- 16/18/24-bit RGB Interfaces
- 800x480 pixels
- All Viewing Angle
- White LED back-light
- Transmissive/ Normally Black
- No Touch Panel
- 650 NITS
- Controller: HX8678C / HX8249A
- RoHS Compliant

Description

This is a color active matrix TFT (Thin Film Transistor) LCD (Liquid Crystal Display) that uses amorphous silicon TFT as a switching device. This model is composed of a transmissive type TFT LCD Panel, driver circuit and a backlight unit. The resolution of the 5.0" TFT LCD contains 800(RGB)x480 pixels and can display up to 16.7M colors.

TFT Features

Low Input Voltage: 3.3V

Display Colors: 16.7M

TFT Interface: 16/18/24-bit RGB

General Information Items	Specification	Unit	Note
	Main Panel		
TFT Display area (AA)	108.0(H) x 64.80(V) (5.0 inch)	mm	-
Driver Element	TFT active matrix	-	-
Display Colors	16.7M	colors	-
Number of pixels	800(RGB)x480	dots	-
TFT Pixel arrangement	RGB vertical stripe	-	-
Pixel Pitch	0.135(H)x0.135(V)	mm	-
Viewing angle	All	o'clock	-
Display mode	Transmissive, Normally Black	-	-
TFT Controller	HX8678C / HX8249A	-	-
Operating temperature	-30-+85	°C	-
Storage temperature	-30-+80	°C	-

Mechanical Information

Item		Min	Typ.	Max	Unit	Note
Module Size	Horizontal (H)		120.70		mm	-
	Vertical (V)		75.90		mm	-
	Depth (D)		2.95		mm	-
	Weight		50		g	

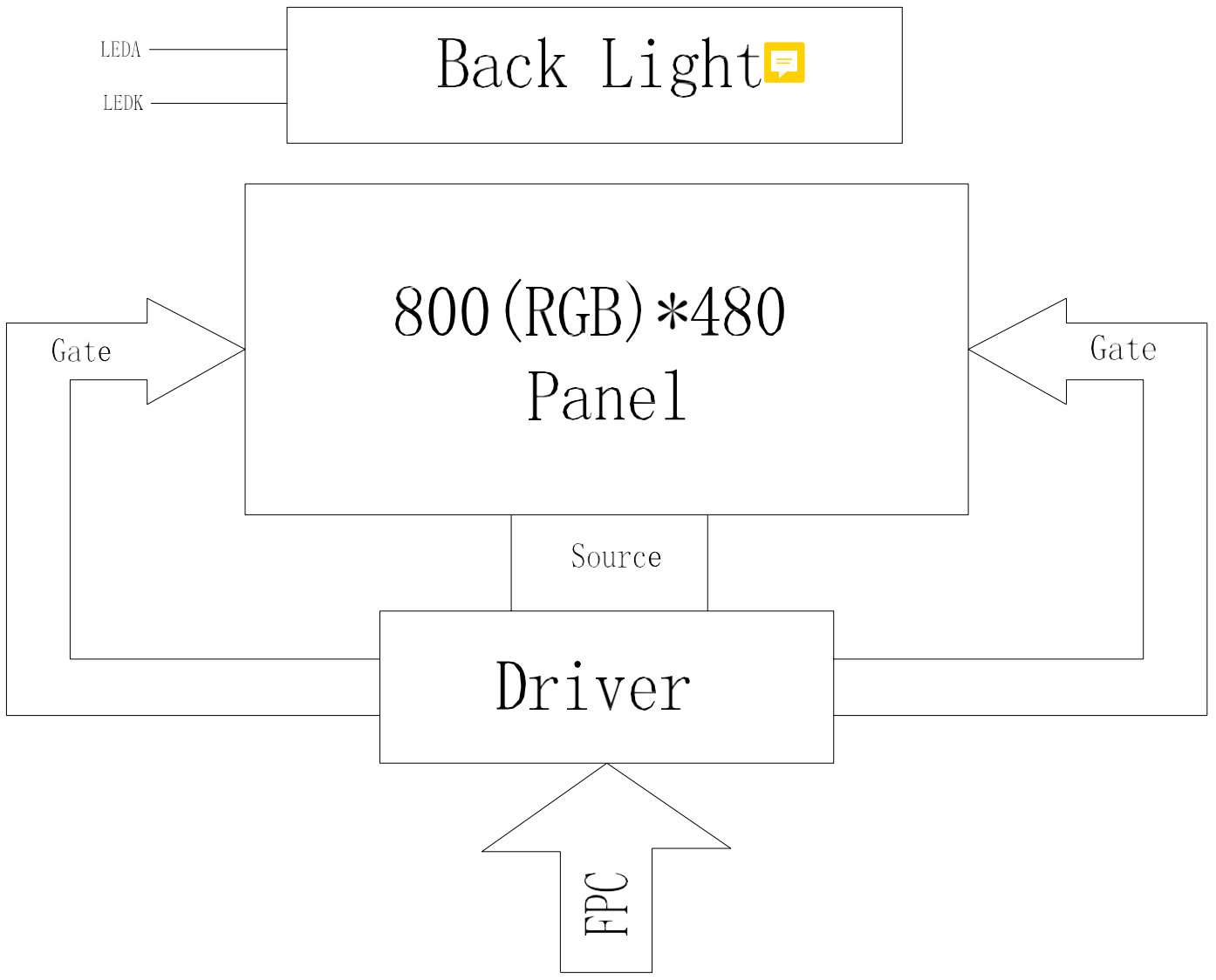



2. Outline Dimensions

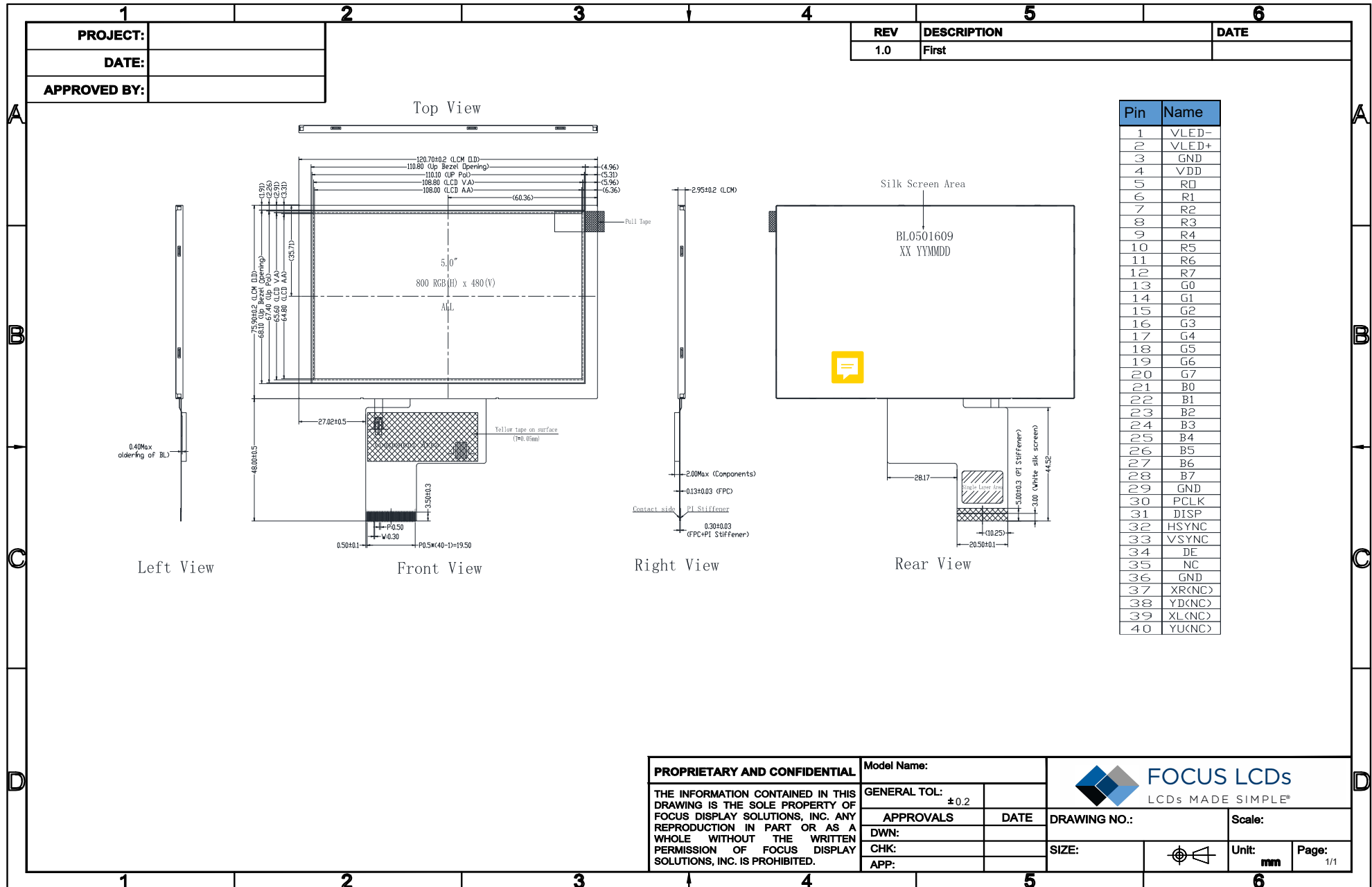

3. Input Terminal Pin Assignment

3.1 TFT

NO.	SYMBOL	DISCRIPTION	I/O						
1	VLED-	Cathode pin of backlight.	P						
2	VLED+	Anode pin of backlight.	P						
3	GND	Ground	P						
4	VDD	Power supply for digital circuits	P						
5-12	R0-R7	8 bit data bus display red data.	I						
13-20	G0-G7	8 bit data bus display green data.	I						
21-28	B0-B7	8 bit data bus display blue data.	I						
29	GND	Ground	P						
30	PCLK	Pixel clock input pin.	I						
31	DISP	DISP sets the display mode.	I						
		<table border="1"> <thead> <tr> <th>DISP</th> <th>Function Description</th> </tr> </thead> <tbody> <tr> <td>L</td> <td>Standby mode</td> </tr> <tr> <td>H</td> <td>Normal display mode</td> </tr> </tbody> </table>		DISP	Function Description	L	Standby mode	H	Normal display mode
		DISP		Function Description					
		L		Standby mode					
H	Normal display mode								
32	HSYNC	Horizontal sync signal input PIN.	I						
33	VSYSN	Vertical sync signal input PIN.	I						
34	DE	Data input enable applied to the RGB interface. Display access is enabled when DE is "H".	I						
35	NC	-	-						
36	GND	Ground	P						
37	XR(NC)	Touch panel Right Glass Terminal	--						
38	YD(NC)	Touch panel Bottom Film Terminal	--						
39	XL(NC)	Touch panel Left Glass Terminal	--						
40	YU(NC)	Touch panel Top Film Terminal	--						

4. LCD Optical Characteristics

4.1 Optical Specifications

Item		Symbol	Condition	Min.	Typ.	Max.	Unit.	Note
Contrast Ratio		CR	$\Theta=0$	800	1000	--		*(1)(2)
Response time	Rising	T_{R+T_F}	Normal viewing angle	--	30	40	msec	*(1)(3)
	Falling			--				
Uniformity		S(%)		45	50	--	%	*
Color Filter Chromaticity	White	W_X		0.2731	0.3131	0.3531		CA-310 Test
		W_Y		0.3059	0.3459	0.3859		
	Red	R_X		0.5478	0.5878	0.6278		
		R_Y		0.3154	0.3554	0.3954		
	Green	G_X		0.3162	0.3562	0.3962		
		G_Y		0.5194	0.5594	0.5994		
	Blue	B_X		0.1121	0.1521	0.1921		
		B_Y		0.0705	0.1105	0.1505		
Viewing angle	Hor.	Θ_L	CR>10	75	80	--		
		Θ_R		75	80	--		
	Ver.	Θ_U		75	80	--		
		Θ_D		75	80	--		
Option View Direction		ALL						

*The data comes from the LCD specification.

5. TFT Electrical Characteristics

5.1 Absolute Maximum Rating (Ta=25 °C, VSS=0V)

Characteristics	Symbol	Min.	Max.	Unit	Note
Digital Supply Voltage	VDD	-0.3	4.0	V	Note1
Operating temperature	T _{OP}	-30	+85	°C	
Storage temperature	T _{ST}	-30	+85	°C	

NOTE: If the absolute maximum rating of the above parameters is exceeded, even momentarily, the quality of the product may be degraded. Absolute maximum ratings specify the values which the product may be physically damaged if exceeded. Be sure to use the product within the range of the absolute maximum ratings.

5.2 DC Electrical Characteristics

Characteristics	Symbol	Min.	Typ.	Max.	Unit	Note
Digital Supply Voltage	VDD	3.3	--	3.6	V	
Normal mode Current consumption	IDD	--	80	--	mA	
Level input voltage	V _{IH}	0.7V _D		VDD	V	
	V _{IL}	GND		0.3 VDD	V	
Level output voltage	V _{OH}	VDD-0.4		--	V	
	V _{OL}	GND		GND+0.4	V	

Optical Specification Reference Notes:

(1) Definition of Viewing Angle: The viewing angle is the angle at which the contrast ratio is greater than 10. The viewing angles are determined for the horizontal or 3,9 o'clock direction and the vertical or 6,12 o'clock direction with respect to the optical axis which is normal to the LCD surface.

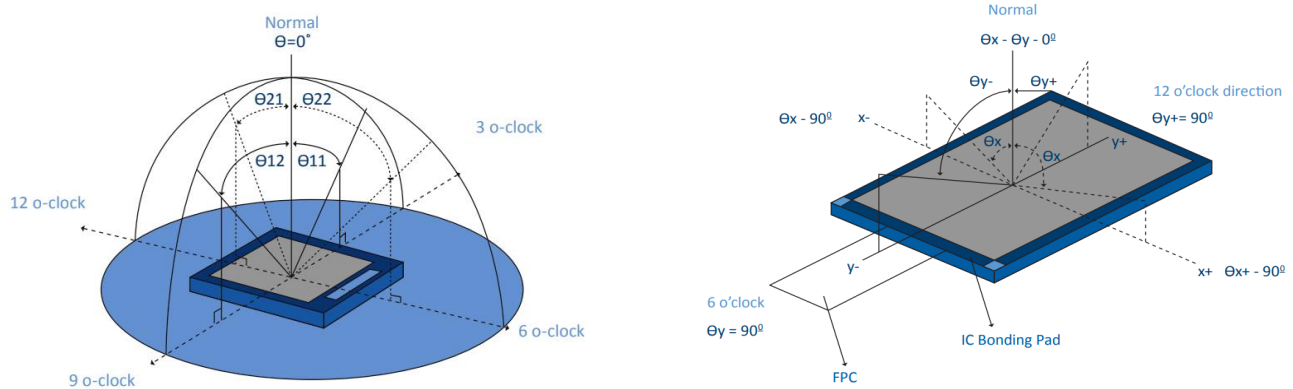

(2) Definition of Contrast Ratio (Cr): measured at the center point of panel. The contrast ratio (Cr) measured on a module, is the ratio between the luminance (Lw) in a full white area (R=G=B=1) and the luminance (Ld) in a dark area (R=G=B=0).

$$Cr = \frac{Lw}{Ld}$$

(3) Definition of transmittance (T%): The transmittance of the panel including the polarizers is measured with electrical driving. The equation for transmittance Tr is:

$$Tr = \frac{I_t}{I_o} \times 100\%$$

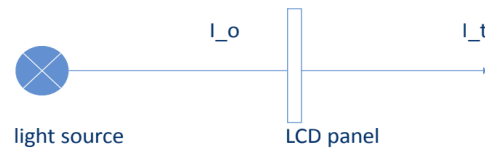

I_o = the brightness of the light source.
 I_t = the brightness after panel transmission

(4) Definition of Response Time (Tr, Tf): The rise time 'Tr' is defined as the time for luminance to change from 90% to 10% as a result of a change of the electrical condition. The fall time 'Tf' is defined as the time for luminance to change from 10% to 90% as a result of a change of the electrical condition.

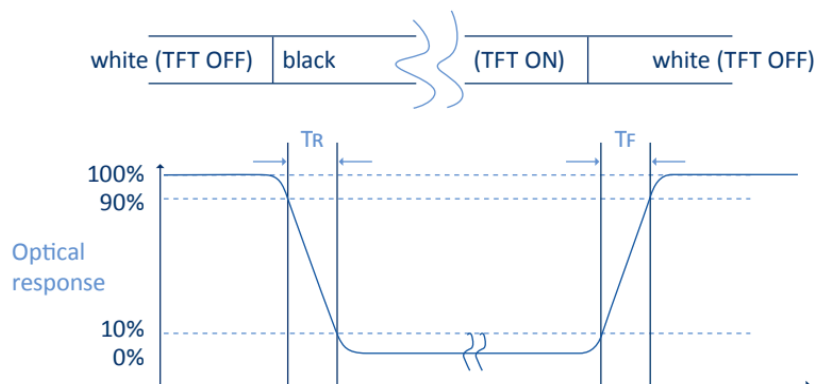

(5) Definition of Color Gamut:

Measuring machine CFT-01. NTSC's Primaries: $R(x,y,Y), G(x,y,Y), B(x,y,Y)$. FPM520 of Westar Display Technologies, INC., which utilized SR-3 for Chromaticity and BM-5A for other optical characteristics. The color chromaticity shall be calculated from the spectral data measured with all pixels first in red, green, blue and white. Measurements shall be made at the center of the panel.

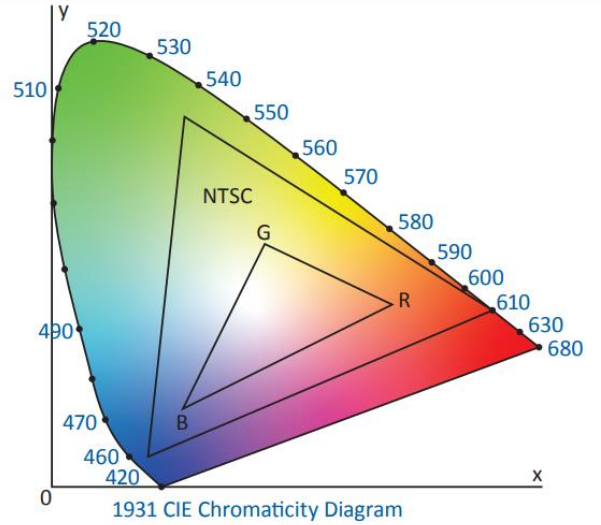
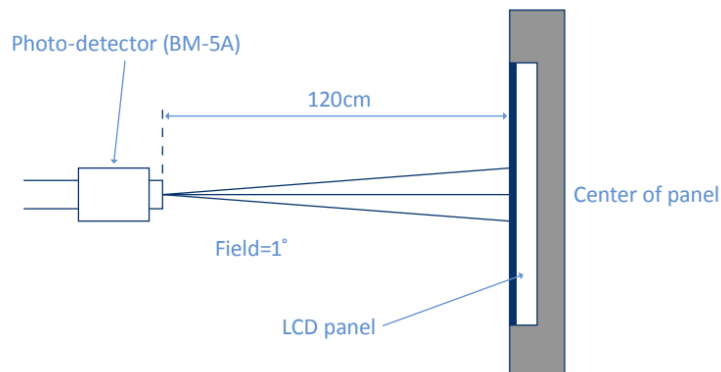
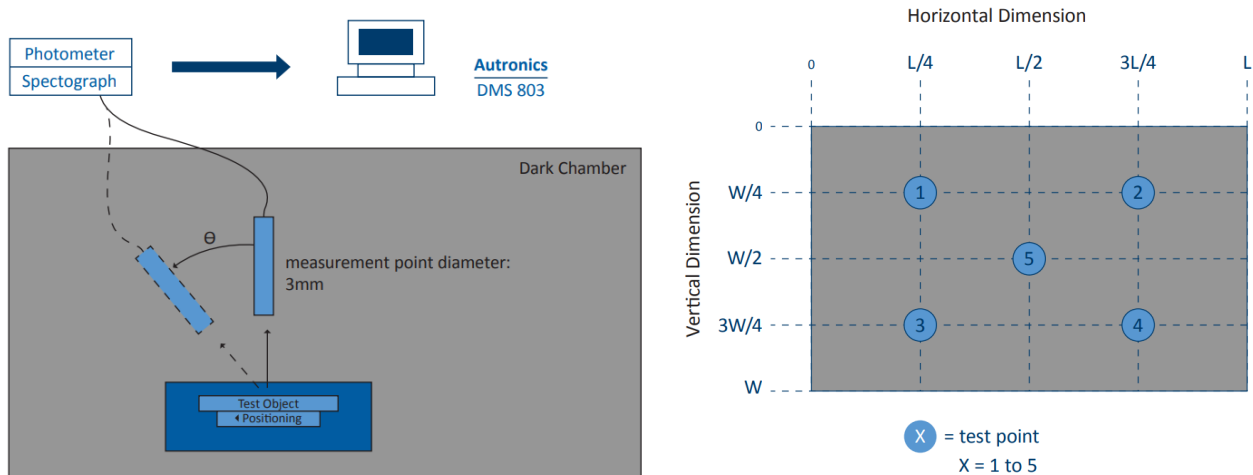

Fig. 1931 CIE chromacity diagram

$$\text{Color gamut: } S = \frac{\text{Area of RGB triangle}}{\text{Area of NTSC triangle}} \times 100\%$$

(6) Definition of Optical Measurement Setup:

The LCD module should be stabilized at a given temperature for 20 minutes to avoid abrupt temperature change during measuring. In order to stabilize the luminance, the measurement should be executed after lighting backlight for 20 minutes.



5.3 LED Backlight Characteristics

The back-light system is edge-lighting type with 16 chips LED

Item	Symbol	Min.	Typ.	Max.	Unit	Note
Forward Current	I_F	30	40	--	mA	
Forward Voltage	V_F	--	25.6	--	V	
LCM Luminance	LV	750	800	--	cd/m ²	Note3
LED life time	Hr	--	50000	--	Hour	Note1,2
Uniformity	Avg	80	--	--	%	Note3

Note1: LED life time (Hr) can be defined as the time in which it continues to operate under the condition:

$T_a=25\pm 3$ °C, typical IL value indicated in the above table until the brightness becomes less than 50%.

Note 2: The “LED life time” is defined as the module brightness decrease to 50% original brightness at

$T_a=25^\circ\text{C}$ and $I_L=40\text{mA}$. The LED lifetime could be decreased if operating I_L is larger than 40mA. The constant current driving method is suggested.

Note (3) Luminance Uniformity of these 9 points is defined as below:

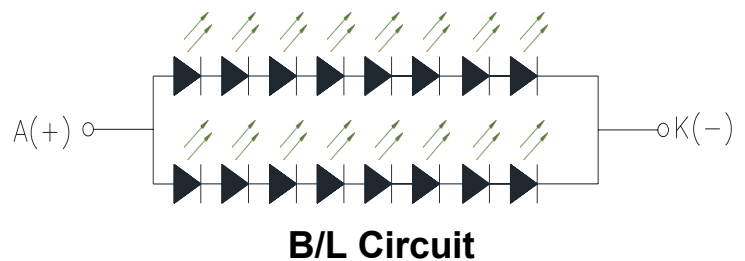
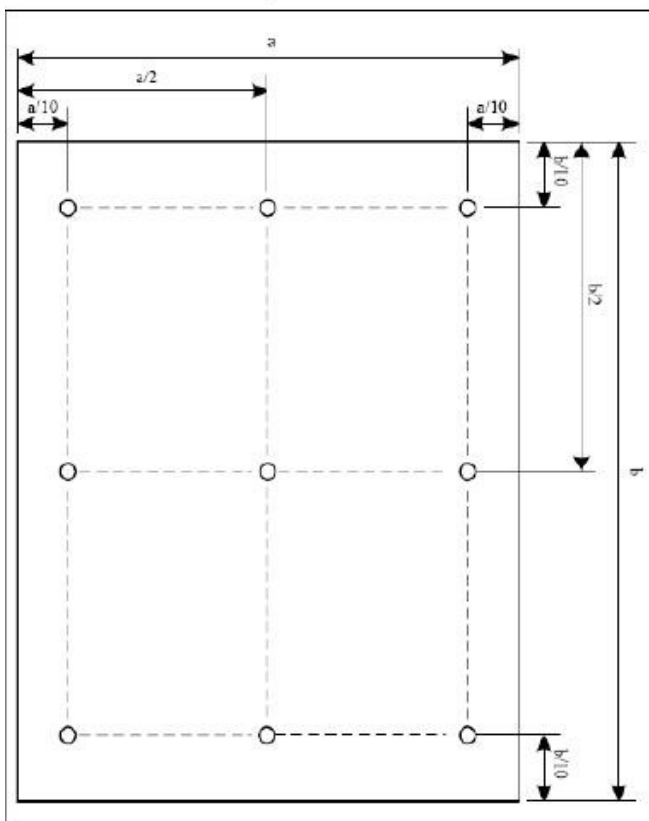

$$\text{Uniformity} = \frac{\text{minimum luminance in 9 points (1-9)}}{\text{maximum luminance in 9 points (1-9)}}$$

$$\text{Luminance} = \frac{\text{Total Luminance of 9 points}}{9}$$

6. AC Characteristics

6.1 RGB Data Bus Timing Signals

Item	Symbol	Min.	Typ.	Max.	Unit	Conditions
CLK Pulse Duty	Tclk	40	50	60	%	
HSYNC Width	Thw	2	-	-	DCLK	
HSYNC Period	Th	55	60	65	us	
VSYNC Setup Time	Tvst	12	-	-	ns	
VSYNC Hold Time	Tvhd	12	-	-	ns	
HSYNC Setup Time	That	12	-	-	ns	
HSYNC Hold Time	Thhd	12	-	-	ns	
Data Setup Time	Tdsu	12	-	-	ns	
Data Hold Time	Tdhd	12	-	-	ns	
DE Setup Time	Tdest	12	-	-	ns	
DE Hold Time	Tdehd	12	-	-	ns	

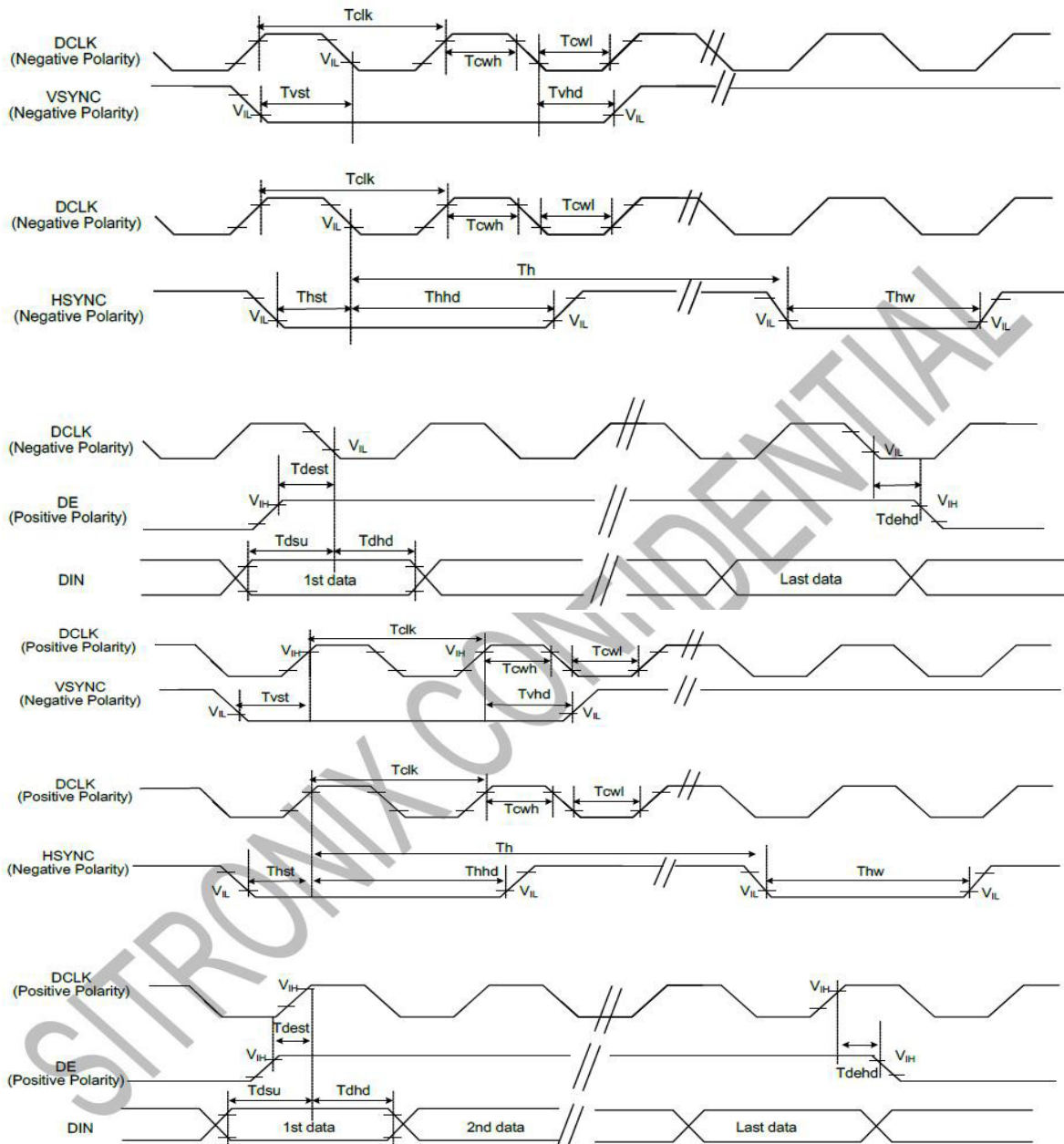

6.2 RGB SYNC Mode

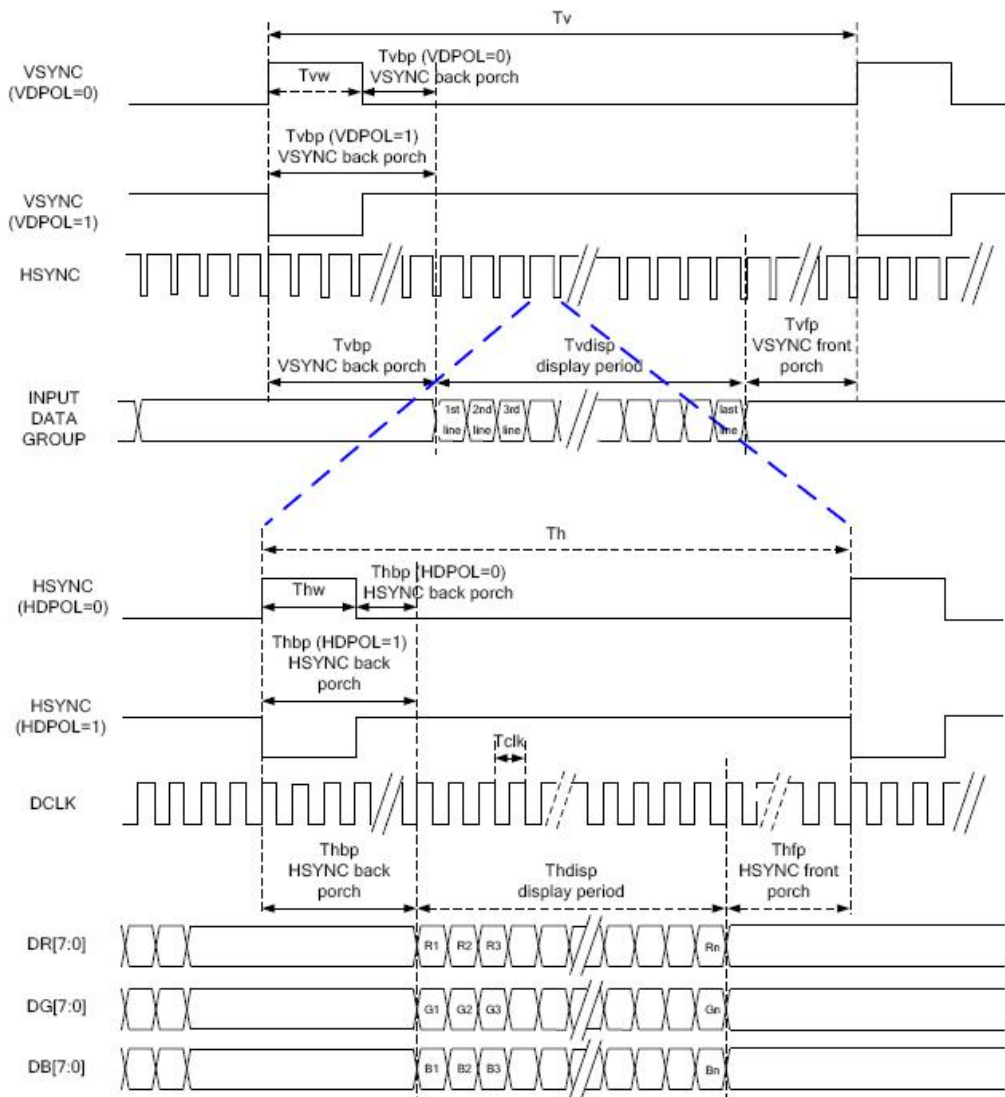

Parallel 24-bit RGB Interface Timing Table

Item	Symbol	Min.	Typ.	Max.	Unit	Remark
DLCK Frequency	Fclk	23	25	27	MHz	
HSYNC	Period Time	Th	808	816	896	DCLK
	Display Period	Thdisp	800			DCLK
	Back Porch	Thbp	4	8	48	DCLK
	Front Porch	Thfp	4	8	48	DCLK
	Pulse Width	Thw	2	4	8	DCLK
VSYNC	Period Time	Tv	488	496	504	HSYNC
	Display Period	Tvdisp	480			HSYNC
	Back Porch	Tvp	4	8	12	HSYNC
	Front Porch	Tvp	4	8	12	HSYNC
	Pulse Width	Tvw	2	4	8	HSYNC

6.3 RGB SYNC-DE Mode

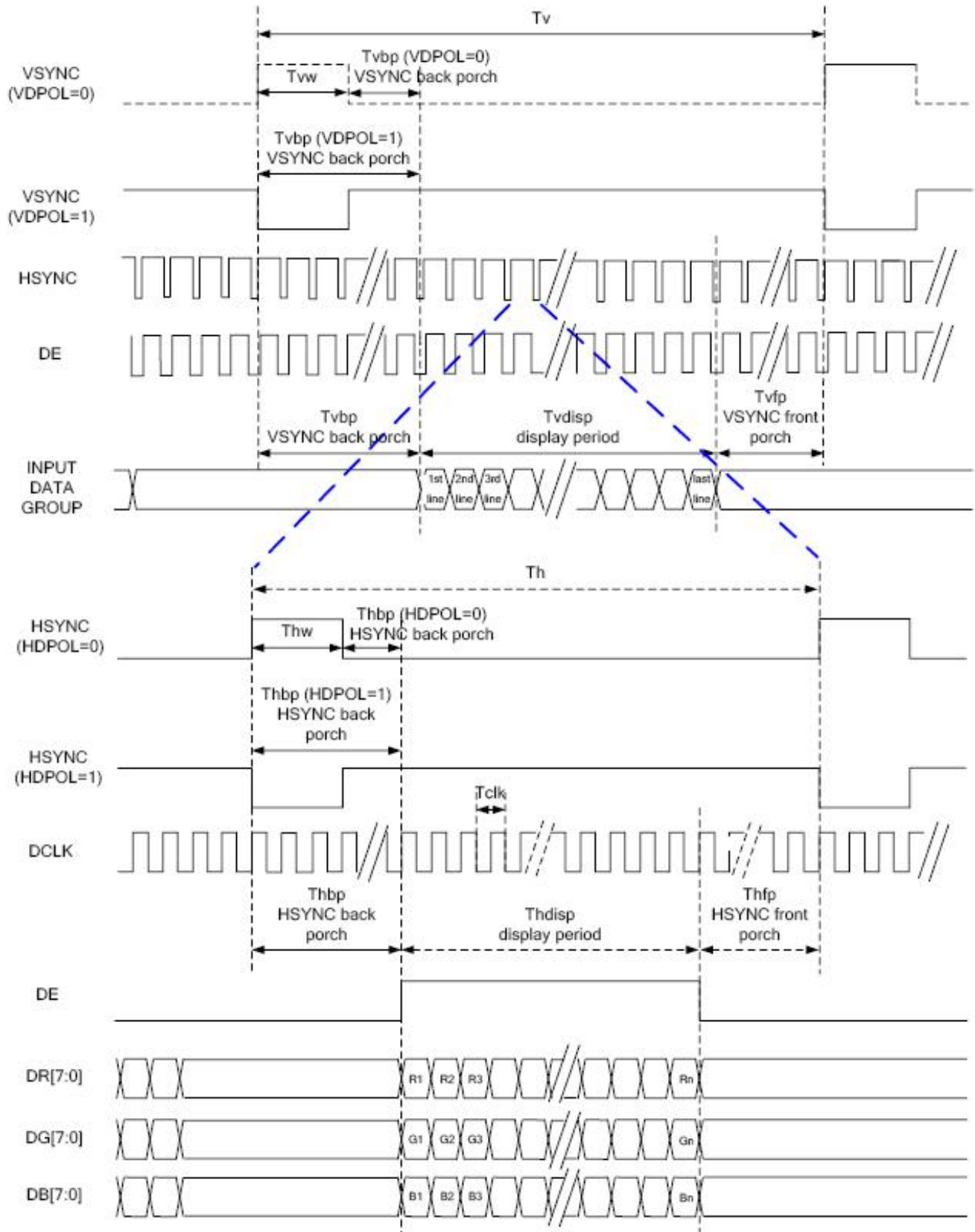

6.4 DE Mode

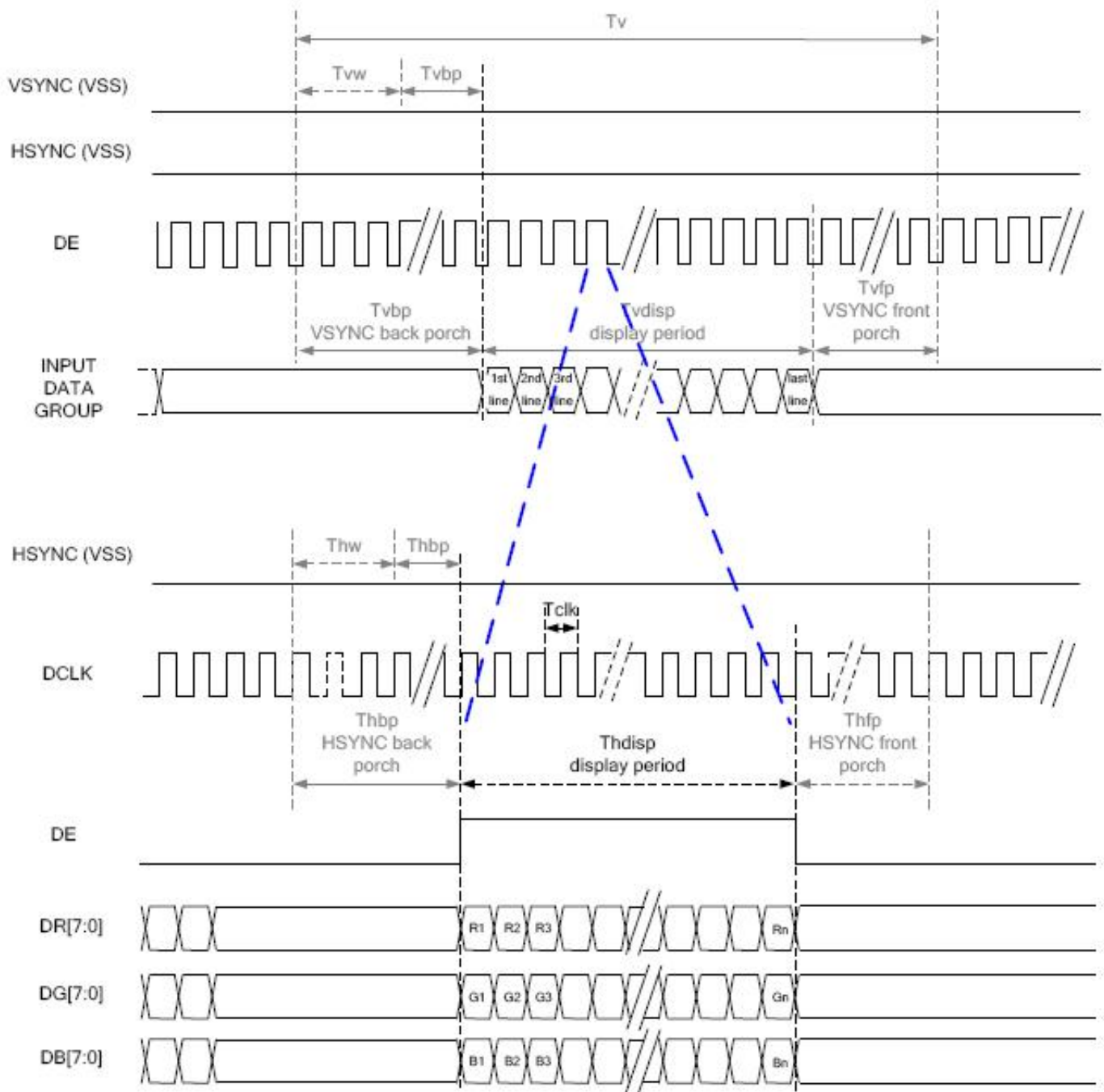

RGB Mode Selection	DCLK	HSYNC	VSYNC	DE
SYNC-DE Mode	Input	Input	Input	Input
SYNC Mode	Input	Input	Input	GND
DE Mode	Input	GND	GND	Input

7. TFT Controller Information

For more information on the TFT drivers, please see links below.

HX8678C

HX8249A

8. Cautions and Handling Precautions

8.1 Handling and Operating the Module

1. When the module is assembled, it should be attached to the system firmly. Do not warp or twist the module during assembly work.
2. Protect the module from physical shock or any force. In addition to damage, this may cause improper operation or damage to the module and back-light unit.
3. Note that polarizer is very fragile and could be easily damaged. Do not press or scratch the surface.
4. Do not allow drops of water or chemicals to remain on the display surface. If you have the droplets for a long time, staining and discoloration may occur.
5. If the surface of the polarizer is dirty, clean it using some absorbent cotton or soft cloth.
6. The desirable cleaners are water, IPA (Isopropyl Alcohol) or Hexane. Do not use ketene type materials (ex. Acetone), Ethyl alcohol, Toluene, Ethyl acid or Methyl chloride. It might permanent damage to the polarizer due to chemical reaction.
7. If the liquid crystal material leaks from the panel, it should be kept away from the eyes or mouth. In case of contact with hands, legs, or clothes, it must be washed away thoroughly with soap.
8. Protect the module from static; it may cause damage to the CMOSICs.
9. Use fingerstalls with soft gloves in order to keep display clean during the incoming inspection and assembly process.
10. Do not disassemble the module.
11. Protection film for polarizer on the module shall be slowly peeled off just before use so that the electrostatic charge can be minimized.
12. Pins of I/F connector shall not be touched directly with bare hands.
13. Do not connect, disconnect the module in the "Power ON" condition.
14. Power supply should always be turned on/off by the item Power On Sequence & Power Off Sequence.

8.2 Storage and Transportation.

1. Do not leave the panel in high temperature, and high humidity for a long time. It is highly recommended to store the module with temperature from 0 to 35 °C and relative humidity of less than 70%
2. Do not store the TFT-LCD module in direct sunlight.
3. The module shall be stored in a dark place. When storing the modules for a long time, be sure to adopt effective measures for protecting the modules from strong ultraviolet radiation, sunlight, or fluorescent light.
4. It is recommended that the modules should be stored under a condition where no condensation is allowed. Formation of dewdrops may cause an abnormal operation or a failure of the module. In particular, the greatest possible care should be taken to prevent any module from being operated where condensation has occurred inside.
5. This panel has its circuitry FPC on the bottom side and should be handled carefully in order not to be stressed.