

MICRO SWITCH Key Actuated Safety Switches



DESCRIPTION

The Honeywell GKE Series key-operated safety interlocking limit switches are designed for machine guarding applications. The switches mount on the EN50047 mounting pattern of the 20 mm to 22mm mounting centers. The compact size is preferred where there is limited space on machinery. The double-insulated plastic housing and rugged stainless steel actuator key is a logical choice for demanding environments. The design of the switch allows the actuator key to be inserted from the top or side of the switch. As with the Honeywell safety limit switches, all normally closed contacts are positive opening ➡.

FEATURES

- Red switch body for easy safety recognition
- 20 mm to 22 mm mounting centers per EN50047 which accept M4 or #8 mounting hardware
- Different contact options; 1NC (normally closed) and 1NO (normally open) or 2NC
- All NC contacts are positive opening ➡ to EN/IEC 60947-5-1-3 specification
- Actuator head can be indexed in any of four positions, in 90° increments
- Switch chamber sealed to IP66/IP67 and NEMA 1, 4X (indoor), 12, 13
- CE, CCC, and cULus certifications for global applications
- Different threaded conduit options
- Designed and agency evaluated, per SIRA, for safety functions up to and including a SIL3 level

APPLICATIONS

- Safety interlock for guards or doors on equipment and machinery
- Designed for hinge or sliding guards or doors

DIFFERENTIATION

- Switch design with dual entry (side or top) for actuator key
- Compact size of 31 mm L × 33 mm W × 96 mm H [1.2 in L × 1.3 in W × 3.8 in H]
- Rigid or flexible stainless steel actuator keys

PORTFOLIO

In addition to the GKE Series safety interlocking limit switches, Honeywell offers other safety interlocking limit switches. These include the miniature plastic body GKM Series, the compact plastic body GKN Series, EN50041 metal body GKB Series, and metal body solenoid (trapped key) GKL/R Series. Non-interlocking safety limit switches include the metal body GSS Series, metal and plastic body non-contact FF Series, metal body 1CPS Series and 2CPS Series cable/rope pull safety limit switches.

MICRO SWITCH KEY ACTUATED SAFETY SWITCHES

GKE SERIES

TABLE 1. PERFORMANCE SPECIFICATIONS

Characteristic	Parameter
Description	Dual entry key-operated safety interlock switch
Agency certifications	CE, DOC A340 cULus, File E37138 CCC, Certificate # 2011010305489827 SIL, Reference SIRA FSP 09009/02
Housing material	Glass-filled thermoplastic polyester
Actuator key material	Stainless steel
Electrical connection	20 mm or 0.5-14 NPT conduit with each wiring point in switch a threaded terminal screw
Contact/switch options¹	1NC/1NO slow action BBM, 1NC/1NO snap action, 2NC slow action
Contact design	Double break, electrically separated (Zb)
Contact material	Silver alloy
Electrical ratings	See table 2
Utilization category	1NC/1NO: AC-15, A600; DC13-Q300 2NC: AC-15, A300; DC13-Q300
Rated operational voltage (U_e)	1NC/1NO: 120 Vac, 240 Vac, 600 Vac, 125 Vdc, 250 Vdc 2NC: 120 Vac, 240 Vac, 125 Vdc, 250 Vdc
Rated operational current (I_e)	1NC/1NO: 6 A, 3 A, 1.2A, 0.55, 0.27 2NC: 6 A, 3 A, 0.55 A, 0.27 A
Thermal current (I_{th})	10 A
Rated insulation (U_i)	1NC/1NO: 600 V 2NC: 300 V
Rated impulse withstand voltage (U_{imp})	2500 V
Short circuit protection device (SCPD)	Class J fuse, 10 A/600 V
Pollution degree	3
Environmental sealing	IP 66/67; NEMA 1, 4X (Indoor), 12, 13
Operating temperature	-25° C to 85° C [-13° F to 185° F]
Shock	50 g per IEC 60068-2-27
Vibration	10 g per IEC 60068-2-6
MCTF (Mechanical life)	15,930,000 cycles
MCTF (Electrical life)	>25,000 cycles with single-sided confidence limit of 75%
SIL Capability²	SIL3 capable with HFT=1 with reference to IEC 61508-2:2010 functional safety
Proof test interval	1 year

¹ All normally closed contacts are positive opening 

² HFT (Hardware Fault Tolerance).

TABLE 2. ELECTRICAL RATINGS

Designation and Utilization Category		Rated Operational Current I _e (A) at Rated Operational Voltage U _e (V)						
		24 V	120 V	240 V	380 V	480 V	500 V	600 V
AC-15	A300	–	6 A	3 A	–	–	–	–
AC-15	A600	–	6 A	3 A	1.9 A	1.5 A	1.4 A	1.2 A
DC-13	Q300	2.8 A	0.55 A	0.27 A	–	–	–	–

MICRO SWITCH KEY ACTUATED SAFETY SWITCHES GKE SERIES

Figure 1. MICRO SWITCH GKE Series Product Nomenclature

GKE	A	03	L	
Switch Type	Conduit	Circuitry	Head Actuation Code ¹	
GKE Series Key-operated safety limit switch	A 0.5-14 NPT	01 1NC/1NO, snap action	L Opening to front and top	Keys² Listing GKZ51M GKZ52M Key style Straight 90°
	C 20 mm	03 1NC/1NO slow action, BBM	M Opening to right and top	
		06 2NC slow action	N Opening to back and top	
			P Opening to left and top	

¹ Actuator head can be field adjusted in increments of 90°. Order GKZT15 bit Torx tamper-resistant bit.
² A key actuator (ordered separately) is required for each switch.

Notes:

1. For other switch options, please contact your Honeywell provider/representative for assistance.
2. Circuitry descriptions apply when key is inserted.

TABLE 3. CIRCUITRY DIAGRAMS^{3,4}

Circuitry Type		
01 • Snap-action contacts	03 • Slow-action contacts	06 • 2NC slow-action contacts (normally closed)

³ Refer to circuitry in product nomenclature (Figure 1).

⁴ The circuits shown are with the key inserted.

TABLE 4. ORDER GUIDE

	Catalog Listing ⁵	Contacts	Electrical Connection/Conduit
	GKEA01L	1NC/1NO snap-action	0.5-14 NPT
	GKEC01L	1NC/1NO snap-action	20 mm
	GKEA03L	1NC/1NO slow action, BBM	0.5-14 NPT
	GKEC03L	1NC/1NO slow action, BBM	20 mm
	GKEA06L	2NC slow action	0.5-14 NPT
	GKEC06L	2NC slow action	20 mm

⁵ An actuator key (ordered separately) is required for each switch. Select actuator key by reviewing product nomenclature tree and dimensional diagrams on pages 3 and 5.

MICRO SWITCH KEY ACTUATED SAFETY SWITCHES GKE SERIES

Figure 3. Product Dimensions mm [in]

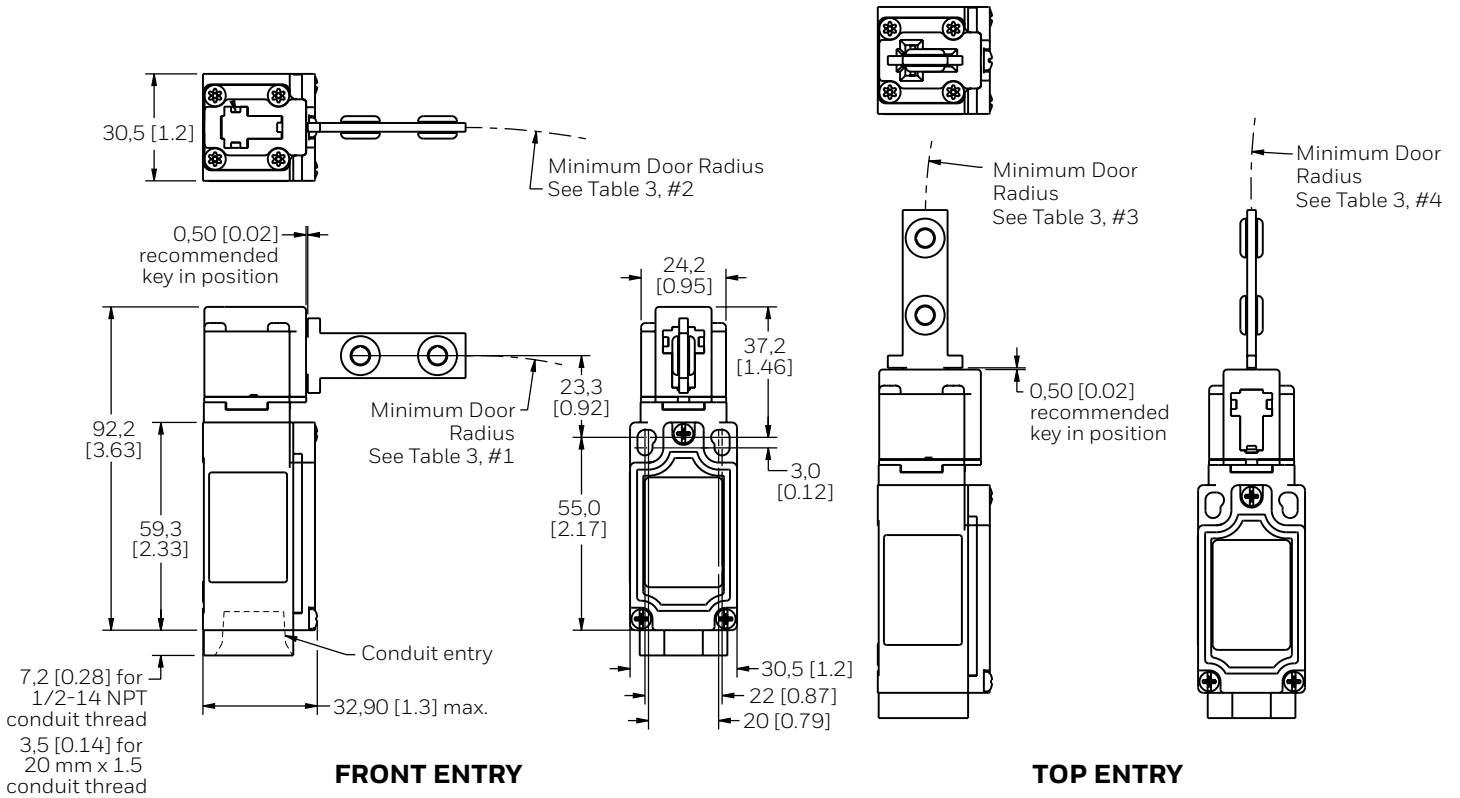

TABLE 5. MINIMUM ACTUATING RADIUS

Catalog Listing, Description	Front Entry Key opening of switch min. radius		Top Entry Key opening of switch min. radius	
	Side View #1	Top View #2	Side View #3	Front View #4
GKZ51M, Straight key	160 mm [6.3 in]	225 mm [8.9 in]	160 mm [6.3 in]	225 mm [8.9 in]
GKZ52M, 90° key (right angle)	160 mm [6.3 in]	225 mm [8.9 in]	160 mm [6.3 in]	225 mm [8.9 in]

MICRO SWITCH KEY ACTUATED SAFETY SWITCHES

GKE SERIES

Figure 4. GKZ51M Key Dimensions

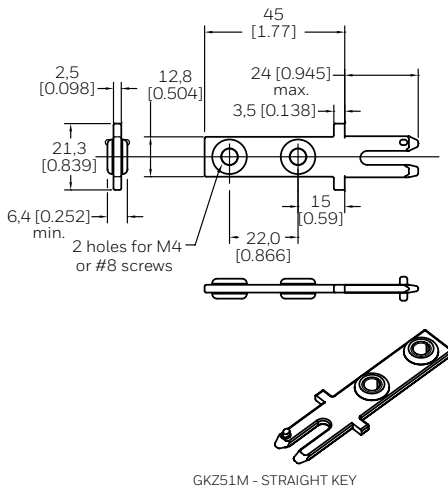
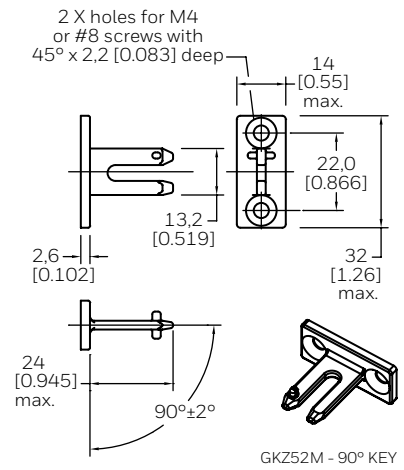

Figure 5. GKZ52M Key Dimensions



WARRANTY/REMEDY

Honeywell warrants goods of its manufacture as being free of defective materials and faulty workmanship during the applicable warranty period. Honeywell's standard product warranty applies unless agreed to otherwise by Honeywell in writing; please refer to your order acknowledgment or consult your local sales office for specific warranty details. If warranted goods are returned to Honeywell during the period of coverage, Honeywell will repair or replace, at its option, without charge those items that Honeywell, in its sole discretion, finds defective. The foregoing is buyer's sole remedy and is in lieu of all other warranties, expressed or implied, including those of merchantability and fitness for a particular purpose. In no event shall Honeywell be liable for consequential, special, or indirect damages.

While Honeywell may provide application assistance personally, through our literature and the Honeywell web site, it is buyer's sole responsibility to determine the suitability of the product in the application.

Specifications may change without notice. The information we supply is believed to be accurate as of this writing. However, Honeywell assumes no responsibility for its use.

For more information

Honeywell Sensing & Safety Technologies services its customers through a worldwide network of sales offices and distributors. For application assistance, current specifications, pricing or the nearest Authorized Distributor, visit [our website](#) or call:

USA/Canada	+1 302 613 4491
Latin America	+1 305 805 8188
Europe	+44 1344 238258
Japan	+81 (0) 3-6730-7152
Singapore	+65 6355 2828
Greater China	+86 4006396841

Honeywell Sensing & Safety Technologies

830 East Arapaho Road
Richardson, TX 75081
www.honeywell.com

WARNING **PERSONAL INJURY**

DO NOT USE these products as safety or emergency stop devices or in any other application where failure of the product could result in personal injury.

Failure to comply with these instructions could result in death or serious injury.

WARNING **MISUSE OF DOCUMENTATION**

- The information presented in this product sheet is for reference only. Do not use this document as a product installation guide.
- Complete installation, operation, and maintenance information is provided in the instructions supplied with each product.

Failure to comply with these instructions could result in death or serious injury.

WARNING **IMPROPER INSTALLATION**

- Consult with local safety agencies and their requirements when designing a machine-control link, interface and all control elements that affect safety.
- Strictly adhere to all installation instructions.

Failure to comply with these instructions could result in death or serious injury.