

HTAT-8/2-0-SP ✓ ACTIVE

RAYCHEM | RAYCHEM HTAT

TE Internal #: NB08184001

Black, 4:1, Dual Wall Tubing, Shrinks To .079 in [2 mm], Irradiated Modified Polyolefin, .315 in [8 mm] Inner Diameter, Flame-Retardant, RAYCHEM HTAT

[View on TE.com >](#)



Heat Shrink Tubing > HTAT Heat Shrink Tubing



Primary Product Color: **Black**

Wall Type: **Dual Wall**

Expanded Inside Diameter (Min): **8 mm [.315 in]**

Recovered Inside Diameter (Max): **2 mm [.079 in]**

Shrink Ratio: **4:1**

[All HTAT Heat Shrink Tubing \(66\)](#)

Features

Product Type Features

Wall Type	Dual Wall
-----------	-----------

Electrical Characteristics

Operating Voltage (Max)	.6 kV
-------------------------	-------

Body Features

Fluid Type	Diesel Fuel, Hydraulic Fluid, Lubricating Oil, Motor Oil, Water
Primary Product Color	Black
Shrink Ratio	4:1
Primary Product Material	Irradiated Modified Polyolefin
Flexibility	Semi-Flexible

Dimensions

Recovered Wall Thickness (Tolerance)	.3 mm[.012 in]
--------------------------------------	----------------



Recovered Wall Thickness (Nominal)	1 mm[.039 in]
Expanded Inside Diameter (Min)	8 mm[.315 in]
Recovered Inside Diameter (Max)	2 mm[.079 in]
Tubing Size Range	2 - 8 mm[.079 - .315 in]

Usage Conditions

Shrink Temperature (Min)	80 °C
Resistance Properties	Moisture
Tubing Flammability Type	Flame-Retardant
Operating Temperature Range	-55 - 125 °C
Recovery Temperature	110 °C

Operation/Application

Mechanical Resistance	Fluids, Mechanical Damage, Strain Relief
-----------------------	--

Product Availability

Applicable Region	Global
-------------------	--------

Packaging Features

Packaging Method	Reel
------------------	------

Other

Meets Low Outgassing Requirements	No
Product Source	Czech Republic

Product Compliance

[For compliance documentation, visit the product page on TE.com>](#)

EU RoHS Directive 2011/65/EU	Compliant
EU ELV Directive 2000/53/EC	Compliant
China RoHS 2 Directive MIIT Order No 32, 2016	No Restricted Materials Above Threshold
EU REACH Regulation (EC) No. 1907/2006	Current ECHA Candidate List: JAN 2024 (240) Candidate List Declared Against: JAN 2024 (240) Does not contain REACH SVHC
Halogen Content	Not Low Halogen - contains Br or Cl > 900 ppm.
Solder Process Capability	Not applicable for solder process capability



Product Compliance Disclaimer

This information is provided based on reasonable inquiry of our suppliers and represents our current actual knowledge based on the information they provided. This information is subject to change. The part numbers that TE has identified as EU RoHS compliant have a maximum concentration of 0.1% by weight in homogenous materials for lead, hexavalent chromium, mercury, PBB, PBDE, DBP, BBP, DEHP, DIBP, and 0.01% for cadmium, or qualify for an exemption to these limits as defined in the Annexes of Directive 2011/65/EU (RoHS2). Finished electrical and electronic equipment products will be CE marked as required by Directive 2011/65/EU. Components may not be CE marked. Additionally, the part numbers that TE has identified as EU ELV compliant have a maximum concentration of 0.1% by weight in homogenous materials for lead, hexavalent chromium, and mercury, and 0.01% for cadmium, or qualify for an exemption to these limits as defined in the Annexes of Directive 2000/53/EC (ELV). Regarding the REACH Regulation, the information TE provides on SVHC in articles for this part number is based on the latest European Chemicals Agency (ECHA) 'Guidance on requirements for substances in articles' posted at this URL: <https://echa.europa.eu/guidance-documents/guidance-on-reach>

Compatible Parts



TE Part # EG1114-000
CV1981-ST-230V1600W-EU

Also in the Series | RAYCHEM HTAT

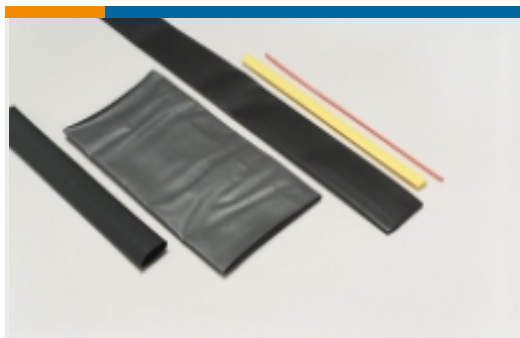

Heat Shrink Tubing(66)

Customers Also Bought

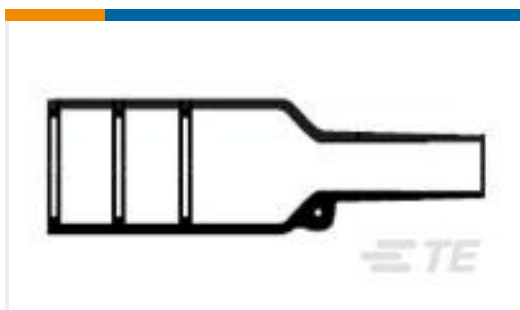

TE Part # 509961-000
202K153-100/86-0



TE Part # CV3304-000
RW-175-1/4-X-STK

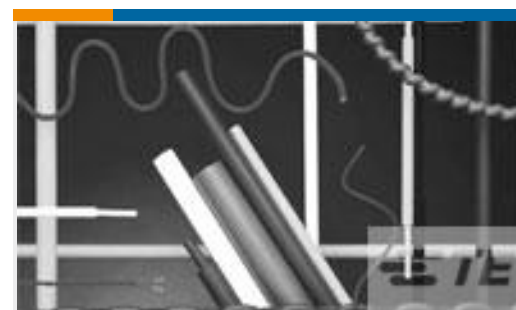

TE Part # 4876424001
CGPT-12.7/6.4-X-FSP

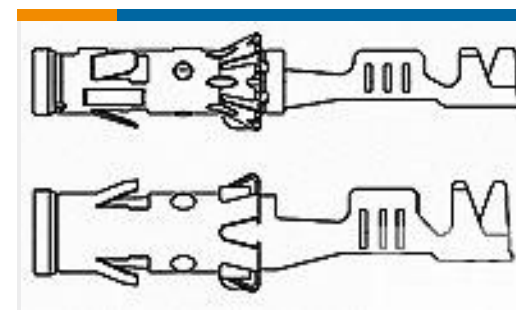

TE Part # 962952-1
4MM SOCKET CONTACT

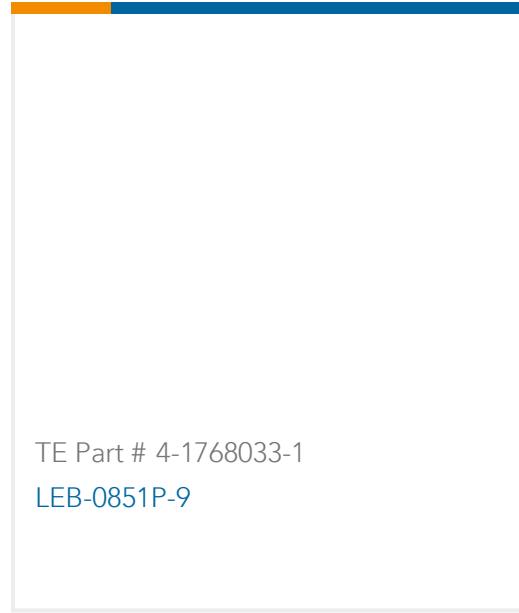
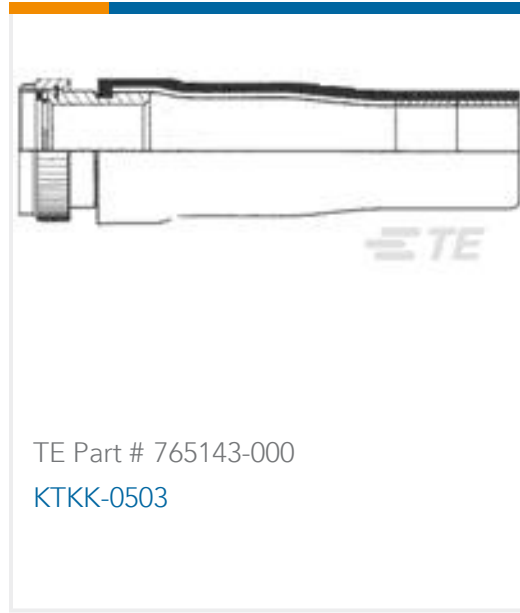
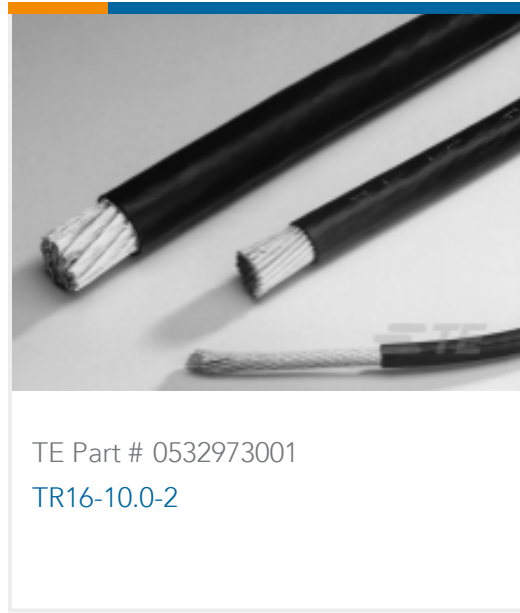

Documents

Product Drawings

[HTAT-8/2-0-SP](#)

English

Datasheets & Catalog Pages

[HTAT Pages from 9-1773447-9](#)

English

Product Specifications

[Application Specification](#)

English