

## SU 10.16HP/04/90SF 3.5AG BK BX

**Weidmüller Interface GmbH & Co. KG**  
Klingenbergstraße 26  
D-32758 Detmold  
Germany

www.weidmueller.com

### Product image

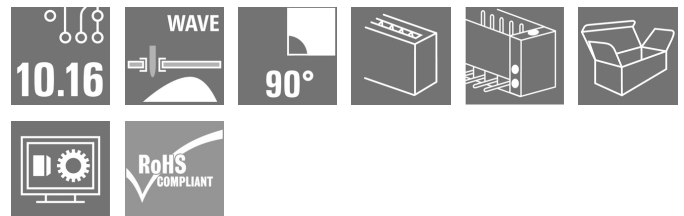

Single-row, high-current male header, for side-by-side mounting without sacrificing any poles, or with patented flange for fast locking without tools. Maximum connection and operating reliability thanks to a mating profile that prevents incorrect connection, with unique coding diversity and additional fastening in the flange. 3.5 mm pin length is optimised for wave soldering, plug-in direction 90° to solder pins.

### General ordering data

Version	PCB plug-in connector, male header, Screw/clip-on flange, THT solder connection, 10.16 mm, Number of poles: 4, 90°, Solder pin length (l): 3.5 mm, silver-plated, black, Box
Order No.	<a href="#">1851060000</a>
Type	SU 10.16HP/04/90SF 3.5AG BK BX
GTIN (EAN)	4032248382026
Qty.	30 pc(s).
Product data	IEC: 1000 V / 78.3 A UL: 300 V / 60 A
Packaging	Box

Creation date June 14, 2024 8:55:29 PM CEST

## SU 10.16HP/04/90SF 3.5AG BK BX

Weidmüller Interface GmbH & Co. KG

Klingenbergstraße 26

D-32758 Detmold

Germany

www.weidmueller.com

## Technical data

### Dimensions and weights

Net weight 23.1 g

### System specifications

Product family	OMNIMATE Power - series BU/SU 10.16HP			
Type of connection	Board connection			
Mounting onto the PCB	THT solder connection			
Pitch in mm (P)	10.16 mm			
Pitch in inches (P)	0.4 "			
Outgoing elbow	90°			
Number of poles	4			
Number of solder pins per pole	3			
Solder pin length (l)	3.5 mm			
Solder pin length tolerance	+0.1 / -0.3 mm			
Solder pin dimensions	1.2 x 1.1 mm			
Solder pin dimensions = d tolerance	+0.1 / -0.1 mm			
Solder eyelet hole diameter (D)	1.6 mm			
Solder eyelet hole diameter tolerance (D)	+ 0,1 mm			
L1 in mm	30.48 mm			
L1 in inches	1.2 "			
Number of rows	1			
Pin series quantity	1			
Touch-safe protection acc. to DIN VDE 57 106	Safe from finger touch, plugged			
Touch-safe protection acc. to DIN VDE 0470	IP20 plugged			
Volume resistance	2.00 mΩ			
Can be coded	Yes			
Tightening torque for screw flange, min.	0.3 Nm			
Tightening torque for screw flange, max.	0.4 Nm			
Tightening torque	Torque type Usage information	Mounting screw, PCB		
		Thickness	min. 1.44 mm	
			max. 1.76 mm	
		Tightening torque	min. 0.25 Nm	
			max. 0.3 Nm	
		Recommended screw	Part number	<a href="#">SU 10.16 BFSC P 35X 14</a>
			Thickness	min. 2.88 mm max. 3.52 mm
		Tightening torque	min. 0.2 Nm	
			max. 0.25 Nm	
		Recommended screw	Part number	<a href="#">SU 10.16 BFSC P 35X 14</a>
			Thickness	min. 1.44 mm max. 3.52 mm
		Tightening torque	min. 0.8 Nm	
max. 0.9 Nm				
Recommended screw	Part number	<a href="#">SU 10.16 BFSC S 35X12</a>		

## SU 10.16HP/04/90SF 3.5AG BK BX

Weidmüller Interface GmbH &amp; Co. KG

Klingenbergstraße 26

D-32758 Detmold

Germany

www.weidmueller.com

## Technical data

## Material data

Insulating material	PBT GF	Colour	black
Colour chart (similar)	RAL 9011	Insulating material group	IIIa
Comparative Tracking Index (CTI)	≥ 200	UL 94 flammability rating	V-0
Contact material	Cu-alloy	Contact surface	silver-plated
Layer structure of solder connection	≥ 3 µm Ag	Layer structure of plug contact	≥ 3 µm Ag
Storage temperature, min.	-40 °C	Storage temperature, max.	70 °C
Operating temperature, min.	-50 °C	Operating temperature, max.	120 °C
Temperature range, installation, min.	-25 °C	Temperature range, installation, max.	120 °C

## Rated data acc. to IEC

tested acc. to standard	IEC 60664-1, IEC 61984	Rated current, min. number of poles (Tu=20°C)	78.3 A
Rated current, max. number of poles (Tu=20°C)	67.9 A	Rated current, min. number of poles (Tu=40°C)	70.6 A
Rated current, max. number of poles (Tu=40°C)	61.3 A	Rated voltage for surge voltage class / pollution degree II/2	1,000 V
Rated voltage for surge voltage class / pollution degree III/2	1,000 V	Rated voltage for surge voltage class / pollution degree III/3	690 V
Rated impulse voltage for surge voltage class/ pollution degree II/2	6 kV	Rated impulse voltage for surge voltage class/ pollution degree III/2	8 kV
Rated impulse voltage for surge voltage class/ contamination degree III/3	8 kV	Short-time withstand current resistance	3 x 1s mit 1000 A
Clearance, min.	8.9 mm	Creepage distance, min.	10.5 mm

## Rated data acc. to CSA

Rated voltage (Use group B / CSA)	300 V	Rated voltage (Use group C / CSA)	300 V
Rated voltage (Use group D / CSA)	600 V	Rated current (Use group B / CSA)	60 A
Rated current (Use group C / CSA)	60 A	Rated current (Use group D / CSA)	5 A

## Rated data acc. to UL 1059

Institute (cURus)		Certificate No. (cURus)	E60693
Rated voltage (Use group B / UL 1059)	300 V	Rated voltage (Use group C / UL 1059)	300 V
Rated voltage (Use group D / UL 1059)	600 V	Rated current (Use group B / UL 1059)	60 A
Rated current (Use group C / UL 1059)	60 A	Rated current (Use group D / UL 1059)	5 A
Clearance distance, min.	8.9 mm	Creepage distance, min.	10.5 mm
Reference to approval values	Specifications are maximum values, details - see approval certificate.		

## Packing

Packaging	Box	VPE length	351 mm
VPE width	138 mm	VPE height	49 mm

**SU 10.16HP/04/90SF 3.5AG BK BX**

**Weidmüller Interface GmbH & Co. KG**  
 Klingenbergstraße 26  
 D-32758 Detmold  
 Germany

[www.weidmueller.com](http://www.weidmueller.com)

**Technical data****Classifications**

ETIM 6.0	EC002637	ETIM 7.0	EC002637
ETIM 8.0	EC002637	ETIM 9.0	EC002637
ECLASS 9.0	27-44-04-02	ECLASS 9.1	27-44-04-02
ECLASS 10.0	27-44-04-02	ECLASS 11.0	27-46-02-01
ECLASS 12.0	27-46-02-01	ECLASS 13.0	27-46-02-01

**Important note**

IPC conformity	Conformity: The products are developed, manufactured and delivered according international recognized standards and norms and comply with the assured properties in the data sheet resp. fulfill decorative properties in accordance with IPC-A-610 "Class 2". Further claims on the products can be evaluated on request.
Notes	<ul style="list-style-type: none"> <li>• Additional variants on request</li> <li>• Rated current related to rated cross-section &amp; min. No. of poles.</li> <li>• P on drawing = pitch</li> <li>• Rated data refer only to the component itself. Clearance and creepage distances to other components are to be designed in accordance with the relevant application standards.</li> <li>• For all applications with flange we recommend to fix the pin header with the help of the soldering flange or a self-tapping screw on the board.</li> <li>• In accordance with IEC 61984, OMNIMATE-connectors are connectors without breaking capacity (COC). During designated use, connectors are not allowed to be engaged or disengaged when live or under load</li> <li>• Long term storage of the product with average temperature of 50 °C and maximum humidity 70%, 36 months</li> </ul>

**Approvals**

Approvals



ROHS	Conform
UL File Number Search	UL Website
Certificate No. (cURus)	E60693

**SU 10.16HP/04/90SF 3.5AG BK BX**

**Weidmüller Interface GmbH & Co. KG**  
Klingenbergstraße 26  
D-32758 Detmold  
Germany

[www.weidmueller.com](http://www.weidmueller.com)

**Technical data****Downloads**

---

Approval/Certificate/Document of Conformity	<a href="#">Declaration of the Manufacturer</a>
Engineering Data	<a href="#">CAD data – STEP</a>
Product Change Notification	<a href="#">PCN_2017_122_PL33x_Packaging_SU1016_DE</a> <a href="#">PCN_2017_122_PL33x_Packaging_SU1016_EN</a>
Catalogues	<a href="#">Catalogues in PDF-format</a>
Brochures	<a href="#">FL DRIVES EN</a> <a href="#">MB DEVICE MANUF. EN</a> <a href="#">FL DRIVES DE</a> <a href="#">FL HEATING ELECTR EN</a> <a href="#">FL APPL_INVERTER EN</a> <a href="#">FL_BASE_STATION_EN</a> <a href="#">FL ELEVATOR EN</a> <a href="#">FL POWER SUPPLY EN</a> <a href="#">FL 72H SAMPLE SER EN</a> <a href="#">PO OMNIMATE EN</a> <a href="#">PO OMNIMATE EN</a>

---

**SU 10.16HP/04/90SF 3.5AG BK BX**

**Weidmüller Interface GmbH & Co. KG**  
 Klingenbergstraße 26  
 D-32758 Detmold  
 Germany

www.weidmueller.com

Drawings

Product image

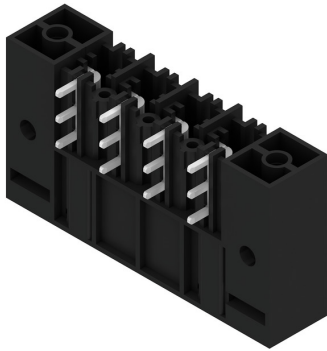

Dimensional drawing

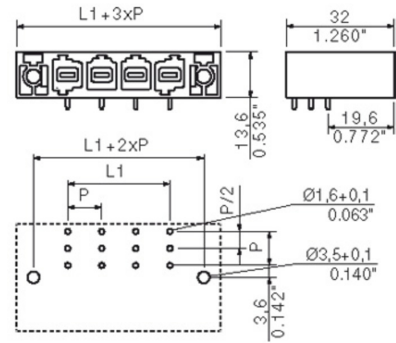

Example of use

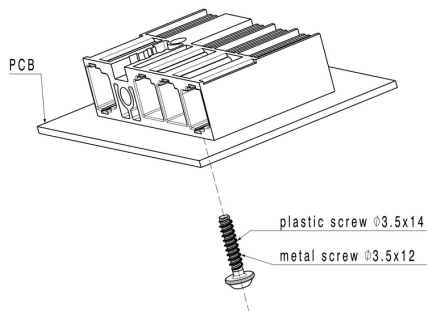

## Recommended wave soldering profiles

**Weidmüller Interface GmbH & Co. KG**  
 Klängenbergstraße 16  
 D-32758 Detmold  
 Germany  
 Fon: +49 5231 14-0  
 Fax: +49 5231 14-292083  
 www.weidmueller.com

### Single Wave:



### Double Wave:



### Wave soldering profiles

Wired connection elements should be processed in accordance with the DIN EN 61760-1 standard. We have included two recommendations for practical wave soldering profiles, with which Weidmüller PCB terminals and connectors are qualified.

When choosing a suitable profile for your application, the following factors also need to be considered:

- PCB thickness
- Proportion of Cu in the layers
- Single/double-sided assembly
- Product range
- Heating and cooling rates

The single and double wave profiles each indicate the recommended operating range, including the maximum soldering temperature of 260°C. In practice, the maximum soldering temperature is quite often well below the above maximum profile.