

PRODUCT NUMBER  
98401-XXX-XXLF

Rohs COMPATIBLE, SEE NOTE 7

TOTAL NB OF POSITIONS, 4 TO 54  
PACKAGING TYPE, NOTE 3

- PLATING
- 1 = 0.76µm GOLD/GXT ON CONTACT AREA, 2µm TlN MIN ON TAILS
  - 4 = 2.0µm TIN MIN FULL PLATED
  - 5 = 0.25µm GOLD/GXT ON CONTACT AREA, 2µm TlN MIN ON TAILS ONLY AVAILABLE UPON REQUEST
  - 8 = 0.38µm GOLD/GXT ON CONTACT AREA, 2µm TIN MIN ON TAILS
- 1.27µm NICKEL MIN UNDERLAYER FOR ALL PLATING VERSIONS

PIN STYLE	MATING	DIM"A"	OAH
01	5.84	9.6	10.2
02	8.08	11.8	12.4
03	13.00	16.8	17.4
06	10.50	14.3	14.9
07	14.50	18.3	18.9
08	7.30	11.1	11.7
09	3.50	7.3	7.9

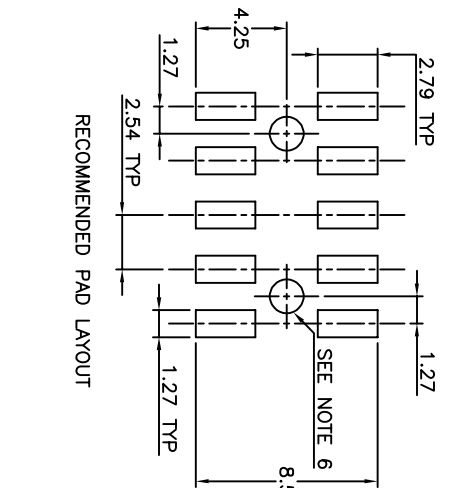
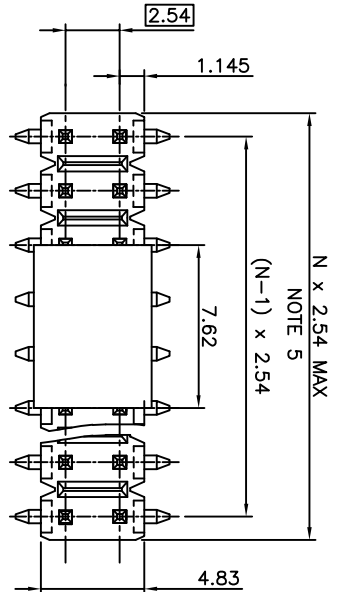

NOTES:

1. HOUSING MAT'L : HIGH TEMPERATURE THERMOPLASTIC: UL94V-0 COLOR: BLACK
2. PIN MATERIAL : PHOSPHOR BRONZE
3. PACKAGING :

- = POLY BAGS
- A = TAPE & REEL WITH PICK UP CAP, AS AVAILABLE
- AV = TAPE & REEL WITH PICK UP CAP FOR CUSTOMER DEDICATED PART
- TV = TUBE WITHOUT PICK UP CAP FOR CUSTOMER DEDICATED PART
- K = TAPE & REEL WITHOUT PICK-UP CAP, AS AVAILABLE.

4. 9N MIN RETENTION IN EITHER DIRECTION
5. TO DETERMINE DIMENSIONS :  
N = NUMBER OF POSITIONS PER ROW  
EXAMPLE : 8 POS N x 2.54 = 20.32mm
6. HOLE DIMENSION TO BE  $\phi 1.6 \pm 0.03$  FOR INTERFERENCE FIT APPLICATIONS.  
HOLE DIMENSIONS TO BE  $\phi 1.95 \pm 0.05$  FOR LOCATION APPLICATION WITH AUTOMATIC PICK AND PLACE MACHINES.
7. ROHS COMPATIBLE PRODUCT SPECIFICATIONS

- d - PLATING:
- "L" MEANS THE PRODUCT IS LEAD-FREE, 2µm MINIMUM MATTE TIN OVER 1.27µm MINIMUM NICKEL UNDERPLATE.
  - b - MANUFACTURING PROCESS COMPATIBILITY  
- THE HOUSING WILL WITHSTAND EXPOSURE TO 260°C PEAK TEMPERATURE FOR 30 SECONDS IN A CONVECTION, INFRA-RED OR VAPOR PHASE REFLOW OVEN.
  - c - LABELING:  
- MEETS PACKAGING SPECS AS PER GS-14-920
  - d - LEGAL STATEMENT: SEE GS-47-0004

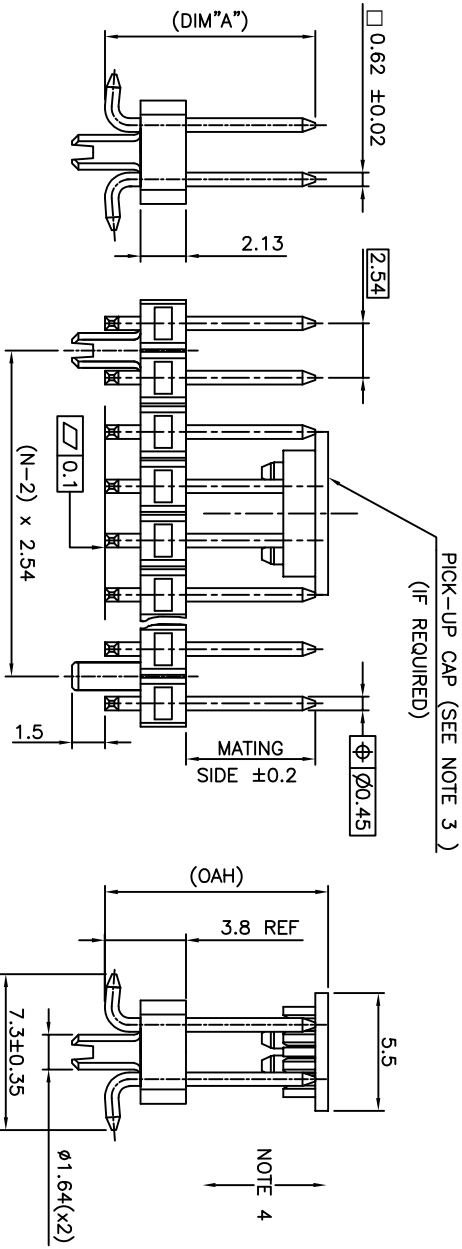

mat'l. code		surface		tolerance		projection		product family	
ltr	ecn no	dr	date	ISO 1302	ISO 406	ISO 1001	mm	BEROSTIK	title
Y	F-25055	JDA	16.09.28	tolerances unless otherwise specified					UNSHR.HEADER
AA	F-28475	LMU	17.05.16						DR SMT
AB	F-31168	DDE	18.09.05						98401
AC	F-47111	DDE	23.01.25						sheet 1 of 1
W	F-23416	JJU	02.03.16						size
X	F-24422	AMA	16.06.30						A3
sheet	revision								Drawing
index	sheet								