

Features

- Floating high-side driver in bootstrap operation to 600V
- Drives two N-channel MOSFETs or IGBTs in a half bridge configuration
- 1.4A source / 1.8A sink output current capability
- Outputs tolerant to negative transients
- Internal dead time of 400ns to protect MOSFETs
- Wide low side gate driver supply voltage: 10V to 20V
- Logic input (IN and SD*) 3.3V capability
- Schmitt triggered logic inputs with internal pull down
- Undervoltage lockout for high and low side drivers
- Extended temperature range: -40°C to +125°C

Applications

- DC-DC Converters
- AC-DC Inverters
- Motor Controls
- Class D Power Amplifiers

Typical Application

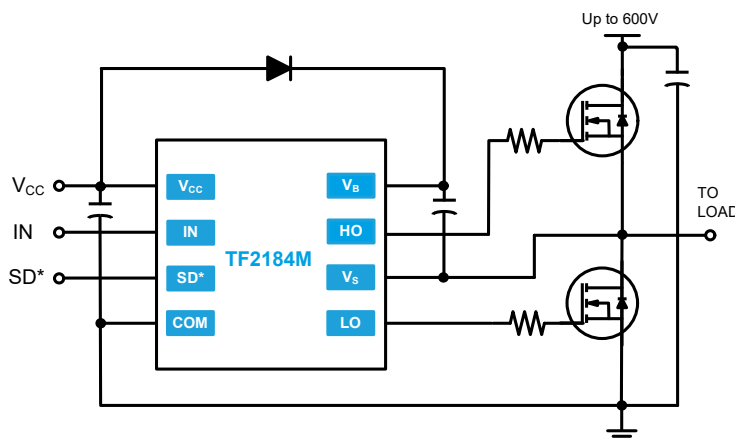

Description

The TF2184M is a high voltage, high speed gate driver capable of driving N-channel MOSFETs and IGBTs in a half bridge configuration. TF Semiconductor’s high voltage process enables the TF2184M’s high side to switch to 600V in a bootstrap operation.

The TF2184M logic inputs are compatible with standard TTL and CMOS levels (down to 3.3V) to interface easily with controlling devices. The driver outputs feature high pulse current buffers designed for minimum driver cross conduction. TF2184M has a fixed internal deadtime of 400ns (typical).

The TF2184M is offered in PDIP-8 and SOIC-8(N) packages and operate over an extended -40°C to +125°C temperature range.



Ordering Information

PART NUMBER	PACKAGE	PACK / Qty	Year	Year	Week	Week
			Year	Year	Week	Week
TF2184M-3AS	PDIP-8	Tube / 50	TF	YY	WW	TF2184M Lot ID
TF2184M-TAU	SOIC-8(N)	Tube / 100	TF	YY	WW	TF2184M Lot ID
TF2184M-TAH	SOIC-8(N)	T&R / 2500	TF	YY	WW	TF2184M Lot ID

Pin Diagrams

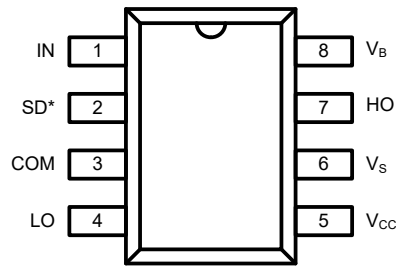

Top View: PDIP-8, SOIC-8

TF2184M

Pin Descriptions

PIN NAME	PIN NUMBER	PIN DESCRIPTION
IN	1	Logic input for high-side and low-side gate driver outputs (HO and LO), in phase with HO.
SD*	2	Logic input for shutdown, enabled low
COM	3	Low-side and logic return
LO	4	Low-side gate drive output
V _{CC}	5	Low-side and logic fixed supply
V _S	6	High-side floating supply return
HO	7	High-side gate drive output
V _B	8	High-side floating supply

Functional Block Diagram

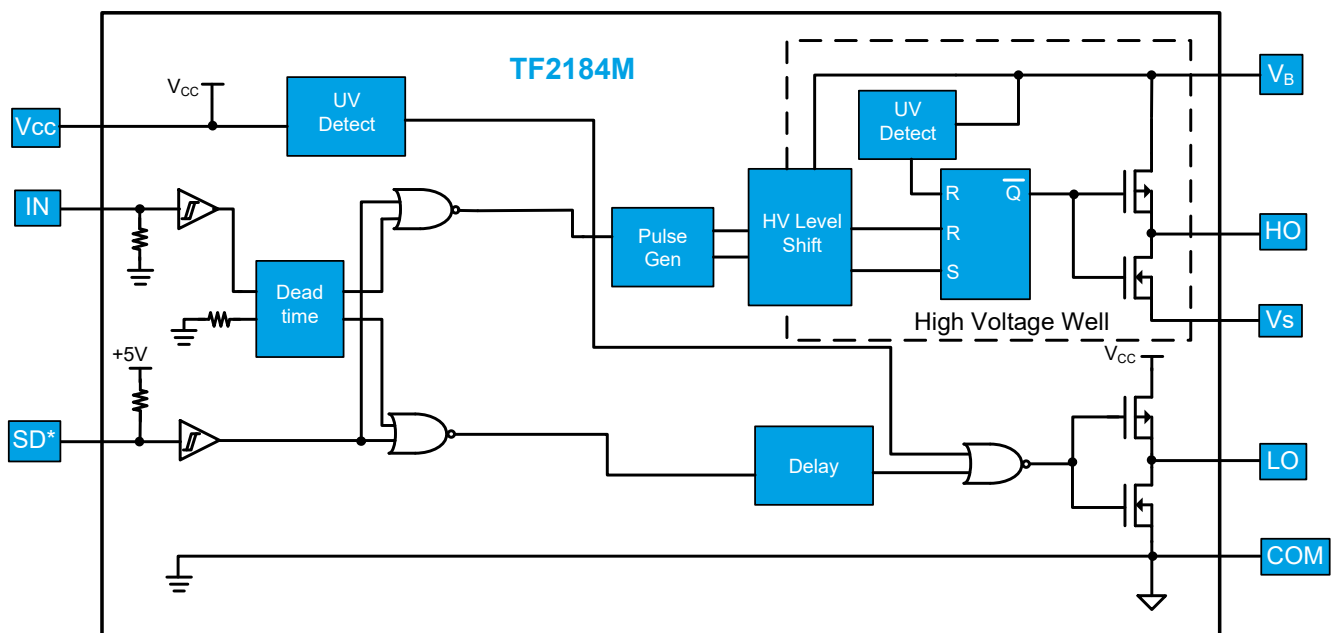

Revision History

Rev.	Change	Owner	Date
1.0	First release, datasheet	D. Walton	12/09/2022

for additional information contact: info@tfsemiconductors.com

Important Notice

TF Semiconductor Solutions (TFSS) PRODUCTS ARE NEITHER DESIGNED NOR INTENDED FOR USE IN MILITARY AND/OR AEROSPACE, AUTOMOTIVE OR MEDICAL DEVICES OR SYSTEMS UNLESS THE SPECIFIC TFSS PRODUCTS ARE SPECIFICALLY DESIGNATED BY TFSS FOR SUCH USE. BUYERS ACKNOWLEDGE AND AGREE THAT ANY SUCH USE OF TFSS PRODUCTS WHICH TFSS HAS NOT DESIGNATED FOR USE IN MILITARY AND/OR AEROSPACE, AUTOMOTIVE OR MEDICAL DEVICES OR SYSTEMS IS SOLELY AT THE BUYER'S RISK.

TFSS assumes no liability for application assistance or customer product design. Customers are responsible for their products and applications using TFSS products.

Resale of TFSS products or services with statements different from or beyond the parameters stated by TFSS for that product or service voids all express and any implied warranties for the associated TFSS product or service. TFSS is not responsible or liable for any such statements.

©2022 TFSS. All Rights Reserved. Information and data in this document are owned by TFSS wholly and may not be edited, reproduced, or redistributed in any way without the express written consent from TFSS.

For additional information please contact support@tfsemi.com or visit www.tfsemi.com.