

PRODUCT NUMBER	QUANTITY PER REEL	PACKAGING	REELING
73396-401	12500	CARDBOARD REEL	"A"
73396-401LF	12500	CARDBOARD REEL	"A"
73396-401RLF	12500	CARDBOARD REEL	"R"
73396-403LF	500	SMALL PLASTIC REEL	"P"

WHEN NEEDED, SUFFIX LETTER "LF" INDICATES THE PRODUCT IS RoHS COMPATIBLE, SEE NOTE

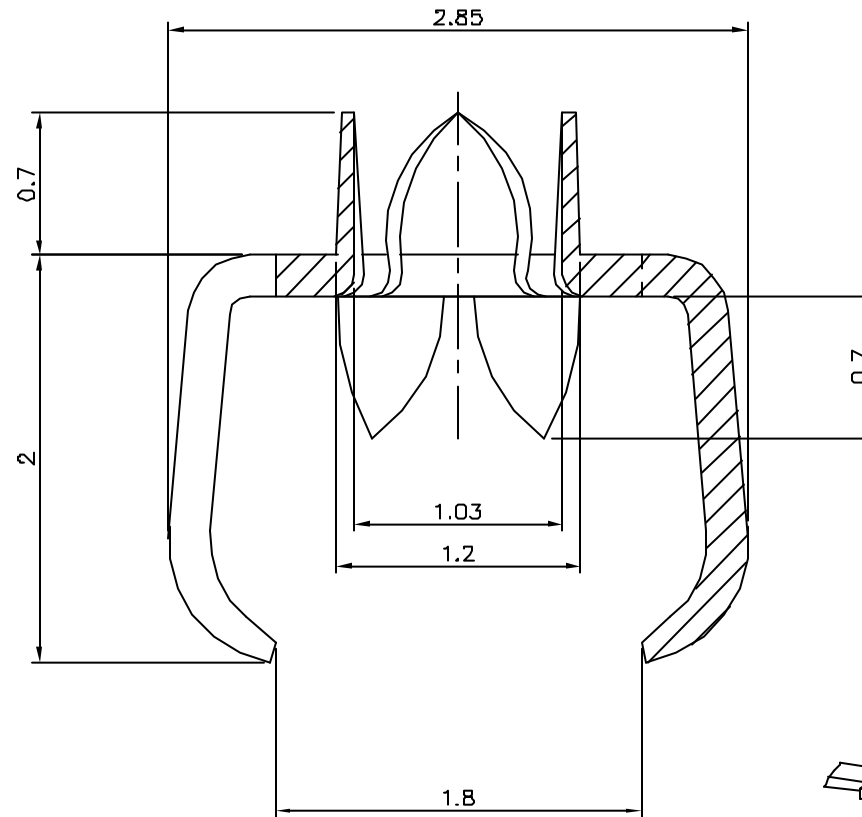

SCALE 40/1

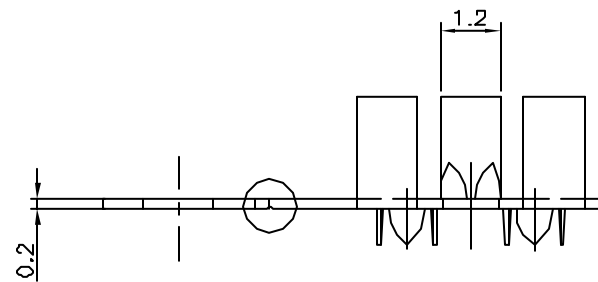
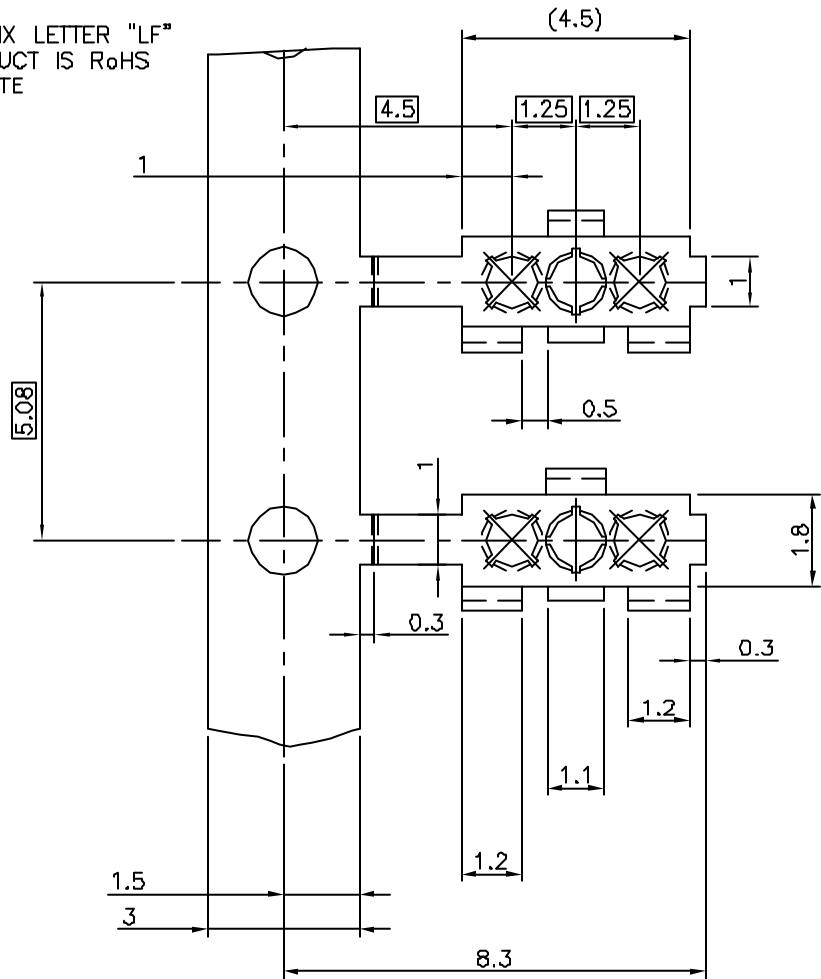
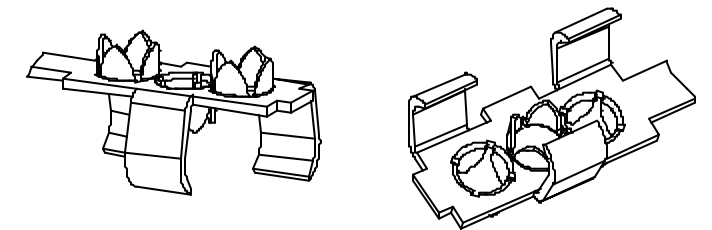
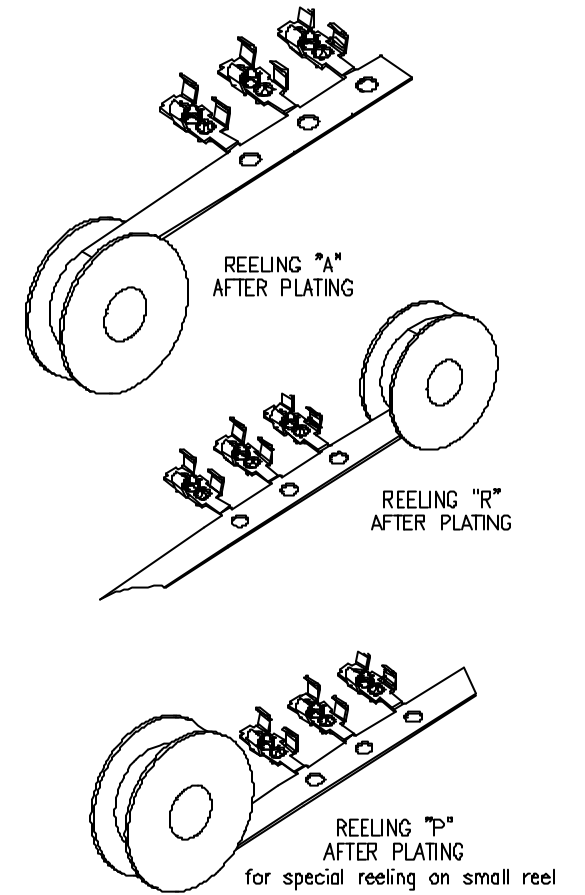

NOTES

- 1 MATERIAL : PHOSPHOR BRONZE 3/4 HARD
- 2 PRODUCT IS POST PLATED
- 3 RoHS COMPATIBLE PRODUCT SPECIFICATIONS

a - PLATING:

- "LF" MEANS THE PRODUCT IS LEAD-FREE, 2µm MINIMUM MATTE TIN OVER 1.27µm MINIMUM NICKEL UNDERPLATE.

b - LABELING:

- MEETS PACKAGING SPECS AS PER GS-14-920

c - LEGAL STATEMENT: SEE GS-22-008

THE PRODUCT IS NOT INTENDED TO BE EXPOSED TO A MANUFACTURING SOLDER PROCESS.

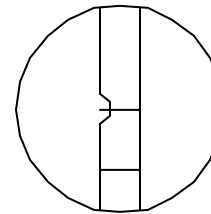

SCALE 40/1

73396-40XLF	1-5µm Sn MIN OVER 1.27µm Ni MIN
73396-40X	1-5µm SnPb MIN OVER 0.1µm Ni MIN
PRODUCT NUMBER	PLATING

mat'l. code	surface	tolerance	projection	product family
SEE NOTES	ISD B12	ISO 406	ISO 111	STAR CRIMP
lit	ech no	dr	date	title
A	F901B4	DLE	99.03.19	STAR CRIMP
B	F10722	JMP	01.12.04	FOIL-WIRE CLINCHER
C	F04-0373	DLE	04.11.19	
D	F05-0284	DLE	05.11.07	
E	F06.0214	DLE	06.06.30	
F	F07-0128	DLE	07.02.08	
G	F07-0282	PNZ	07.12.03	
sheet index	revision	sheet		