

REVISIONS				
REV.	ECO. NO	DESCRIPTION	DATE	BY
E	2511	REMOVED 'B' MOUNTING & UPDATED DWG FORMAT	2/6/2013	KV
F	2953	UPDATE NOTE 7 OPERATING VOLTAGE AND NOTE 16 HOLE SIZE REQUIREMENTS	6/30/2014	JHSU
G	4723	CHANGED THE COMPLIANT FEATURE FROM ACTION PIN TO EYE OF THE NEEDLE, ADDED INSULATOR COLOR	8/29/2023	JH

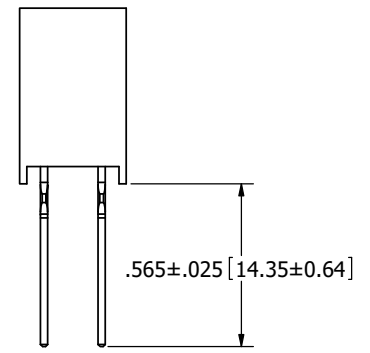
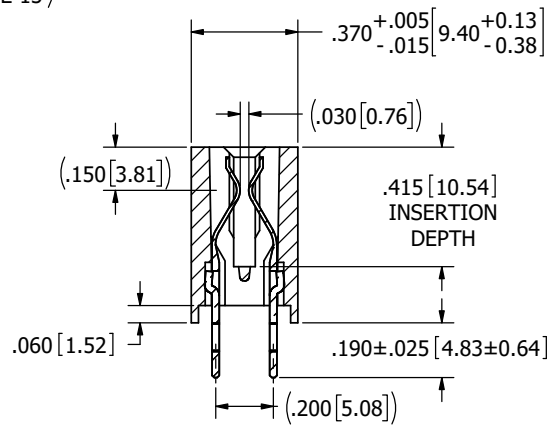
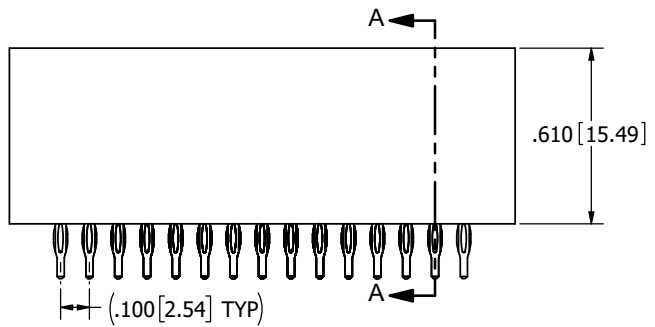
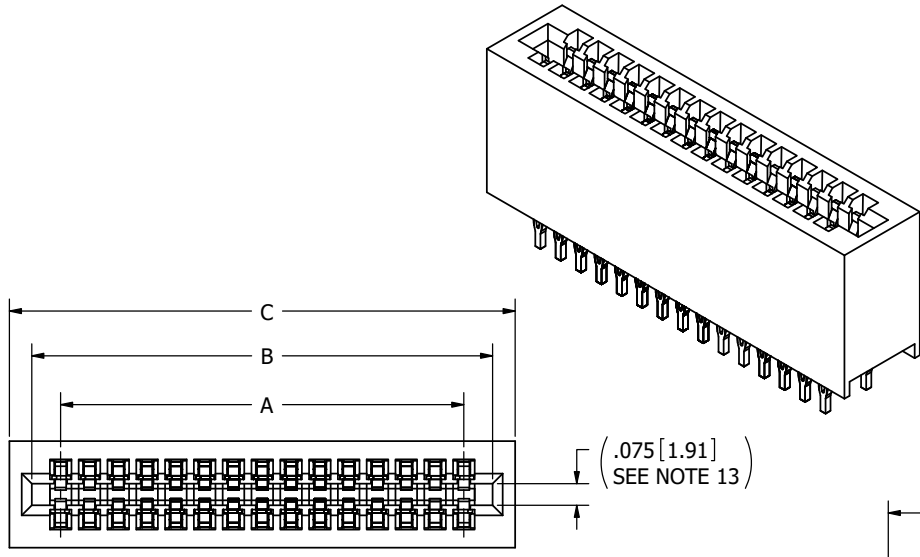

**SECTION A-A**

**ECC \_\_ DJWN  
STANDOFF: YES  
SCOOP: NO**

**ECC \_\_ DJXN  
STANDOFF: YES  
SCOOP: NO**

- NOTES:**
- INSULATOR MATERIAL: BLACK PBT
  - CONTACT MATERIAL: PHOSPHOR BRONZE
  - PLATING: .000050" MIN NICKEL UNDERPLATE  
CONTACT SURFACE: .000030" GOLD  
TERMINATION: .000100" PURE TIN, MATTE
  - OPERATING TEMPERATURE: -65°C TO +125°C
  - PROCESSING TEMP: WAVE/MANUAL SOLDERING ONLY
  - UL FLAMMABILITY RATING: 94V-0
  - DIELECTRIC WITHSTANDING VOLTAGE: 1350 VAC AT SEA LEVEL
  - CURRENT RATING: 3 AMP
  - CONTACT RESISTANCE: 30 MILLI OHMS MAX
  - INSULATION RESISTANCE: 5000 MEGA OHMS
  - DURABILITY: 500 CYCLES MIN
  - CONNECTOR IDENTIFICATION: THE PART SHALL BE MARKED WITH A PART NUMBER AND LOT CODE
  - BOARD THICKNESS ACCOMMODATED: .062 ± .008 [1.57 ± 0.20]
  - INSERTION FORCE: 16 OZ MAX PER CONTACT PAIR WHEN USING A .062 [1.57] TEST BLADE  
INTERNAL INSPECTION TO BE PER SULLIN'S WORK INSTRUCTION WI-8.6-03
  - WITHDRAWAL FORCE: 1 OZ MIN PER CONTACT PAIR USING .062 [1.57] PCB
  - HOLE SIZE REQUIREMENTS:  
DRILLED HOLE DIAMETER: .0453 ± .0010 [1.150 ± 0.025]  
PLATING: .001 [0.03] TO .003 [0.08] COPPER, .0003 [0.008] MINIMUM TIN  
FINISHED HOLE DIAMETER: .040 ± .003 [1.02 ± 0.08]
  - RECOMMENDED MOTHER BOARD THICKNESS: .093 [2.36] TO .125 [3.18] THICK
  - MODIFICATION: SEE PART NUMBER CODING

**CUSTOMER COPY**



UNLESS OTHERWISE SPECIFIED:  
DIMENSIONS ARE IN INCHES (MM)

TOLERANCES:  
ANGULAR: ± 1°

DECIMALS  
XX = ± .02 [5]  
XXX = ± .005 [13]  
XXXX = ± .0005 [013]

DRAWN	DATE	NAME		
	05/04/06	MNH		
<small>THE INFORMATION HEREIN CONTAINS PROPRIETARY INFORMATION OF SULLINS ELECTRONICS AND IS NOT TO BE REPRODUCED, USED OR DISCLOSED TO OTHERS FOR ANY PURPOSE EXCEPT AS SPECIFICALLY AUTHORIZED IN WRITING BY AN OFFICER OF SULLINS ELECTRONICS.</small>			TITLE	EDGE CARD, .100 CC PRESS FIT
			PART NUMBER	ECC __ DJ __, (-S1136)
SIZE	CAGE CODE	DWG. NO.	REV	
C	54453	C10713	G	
SCALE: 3:1				SHEET 1 OF 5

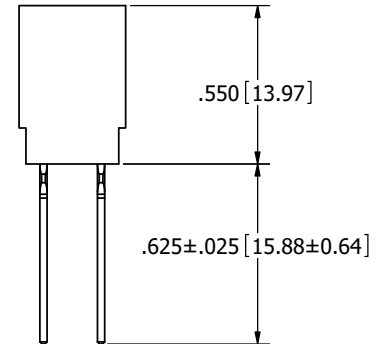
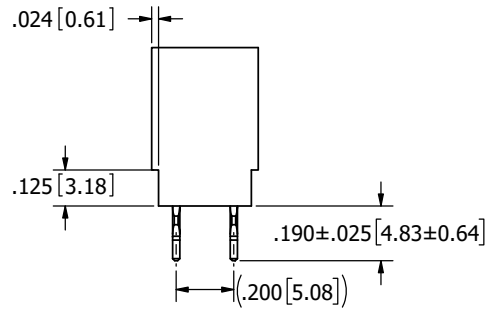
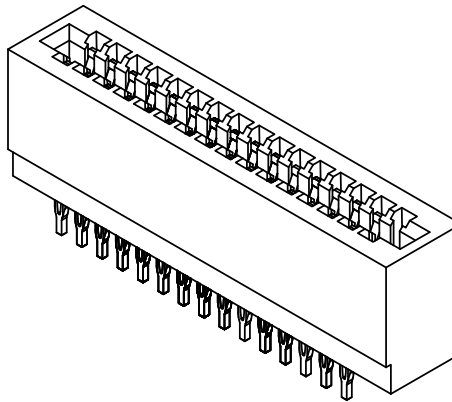
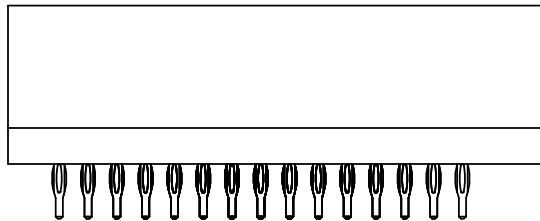
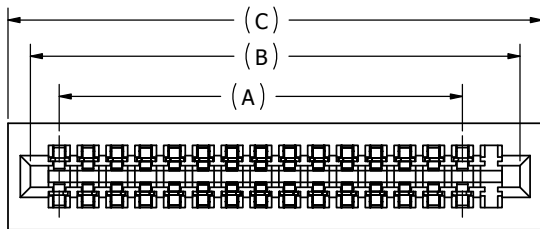

**ECC \_ \_ DJBN**  
**STANDOFF: NO**  
**SCOOP: NO**

**ECC \_ \_ DJCN**  
**STANDOFF: NO**  
**SCOOP: NO**

**CUSTOMER COPY**



RoHS COMPLIANT

UNLESS OTHERWISE SPECIFIED: DIMENSIONS ARE IN INCHES (MM)		DRAWN	DATE	NAME	
TOLERANCES: ANGULAR: $\pm 1^\circ$ DECIMALS .XX = $\pm .02 [5]$ .XXX = $\pm .005 [13]$ .XXXX = $\pm .0005 [13]$			05/04/06	MNH	
TITLE					EDGE CARD, .100 CC PRESS FIT
PART NUMBER					ECC _ _ DJ _ _ (-S1136)
SIZE	CAGE CODE	DWG. NO.	REV		
C	54453	C10713	G		
SCALE: 3:1			SHEET 2 OF 5		

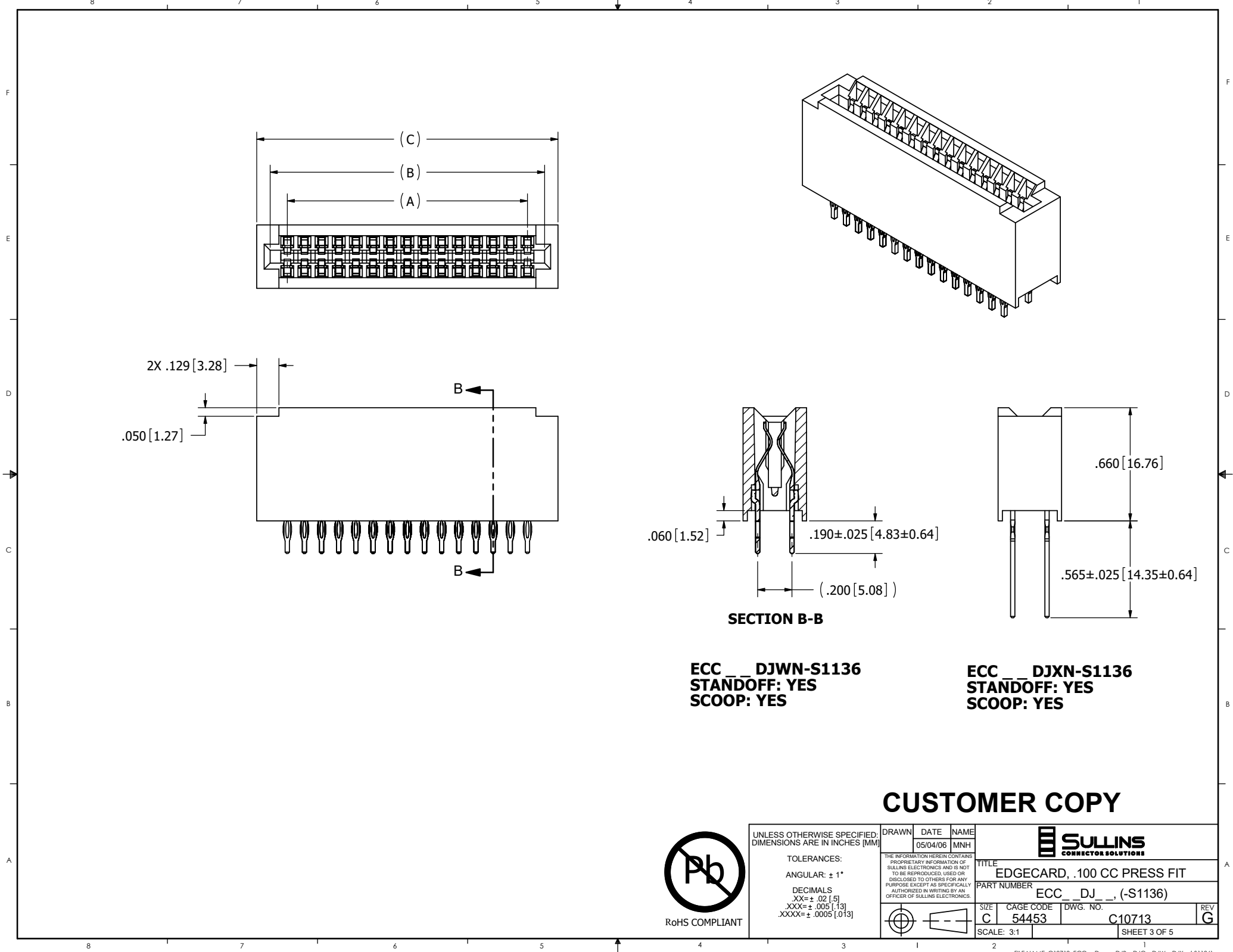

**ECC\_DJWN-S1136**  
**STANDOFF: YES**  
**SCOOP: YES**

**ECC\_DJXN-S1136**  
**STANDOFF: YES**  
**SCOOP: YES**

**CUSTOMER COPY**



UNLESS OTHERWISE SPECIFIED: DIMENSIONS ARE IN INCHES [MM]		DRAWN	DATE	NAME	
TOLERANCES: ANGULAR: $\pm 1^\circ$ DECIMALS .XX = $\pm .02 [5]$ .XXX = $\pm .005 [13]$ .XXXX = $\pm .0005 [013]$			05/04/06	MNH	
					TITLE
					EDGE CARD, .100 CC PRESS FIT
					PART NUMBER
					ECC_DJ_ (-S1136)
SIZE	CAGE CODE	DWG. NO.			REV
C	54453	C10713			G
SCALE: 3:1					SHEET 3 OF 5

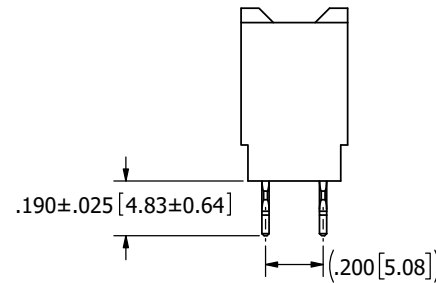
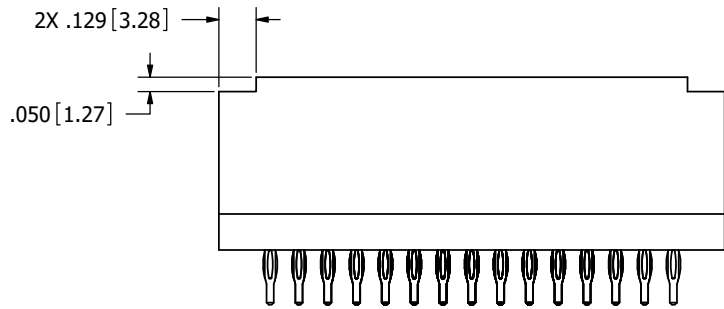
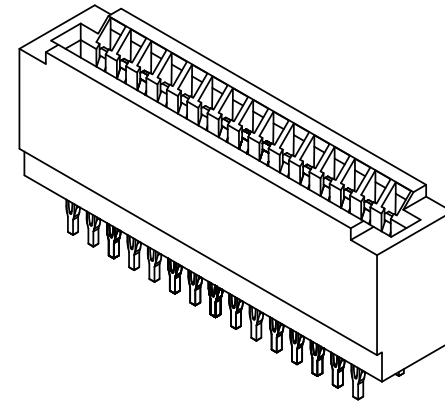
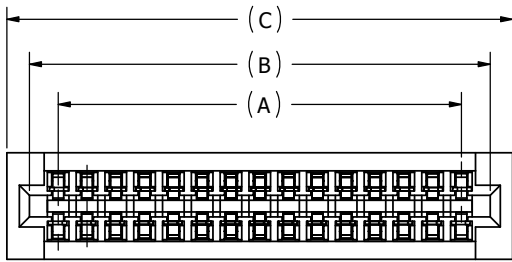

**ECC\_\_DJBN-S1136**  
**STANDOFF: NO**  
**SCOOP: YES**

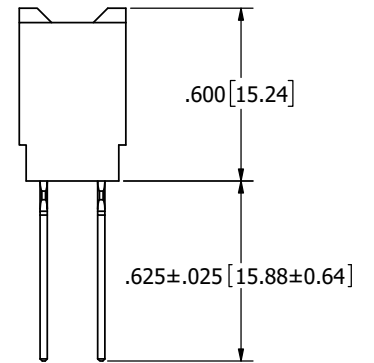

**ECC\_\_DJCN-S1136**  
**STANDOFF: NO**  
**SCOOP: YES**

**CUSTOMER COPY**

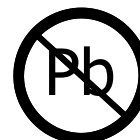

RoHS COMPLIANT

UNLESS OTHERWISE SPECIFIED:  
 DIMENSIONS ARE IN INCHES (MM)

TOLERANCES:  
 ANGULAR:  $\pm 1^\circ$

DECIMALS  
 .XX =  $\pm .02 [5]$   
 .XXX =  $\pm .005 [13]$   
 .XXXX =  $\pm .0005 [13]$

DRAWN	DATE	NAME
	05/04/06	MNH

THE INFORMATION HEREIN CONTAINS  
 PROPRIETARY INFORMATION OF  
 SULLINS ELECTRONICS AND IS NOT  
 TO BE REPRODUCED, USED OR  
 DISCLOSED TO OTHERS FOR ANY  
 PURPOSE EXCEPT AS SPECIFICALLY  
 AUTHORIZED IN WRITING BY AN  
 OFFICER OF SULLINS ELECTRONICS.

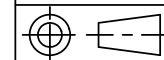

TITLE EDGE CARD, .100 CC PRESS FIT			
PART NUMBER ECC__DJ__, (-S1136)			
SIZE C	CAGE CODE 54453	DWG. NO. C10713	REV G
SCALE: 3:1		SHEET 4 OF 5	

PART NUMBER	NO. OF POSITIONS	A±.008[0.20]		B±.008[0.20]		C±.015[0.38]	
		INCH	MM	INCH	MM	INCH	MM
ECC05D	5	0.400	10.16	0.600	15.24	0.756	19.20
ECC06D	6	0.500	12.70	0.700	17.78	0.856	21.74
ECC07D	7	0.600	15.24	0.800	20.32	0.956	24.28
ECC08D	8	0.700	17.78	0.900	22.86	1.056	26.82
ECC09D	9	0.800	20.32	1.000	25.40	1.156	29.36
ECC10D	10	0.900	22.86	1.100	27.94	1.256	31.90
ECC11D	11	1.000	25.40	1.200	30.48	1.356	34.44
ECC12D	12	1.100	27.94	1.300	33.02	1.456	36.98
ECC13D	13	1.200	30.48	1.400	35.56	1.556	39.52
ECC14D	14	1.300	33.02	1.500	38.10	1.656	42.06
ECC15D	15	1.400	35.56	1.600	40.64	1.756	44.60
ECC16D	16	1.500	38.10	1.700	43.18	1.856	47.14
ECC17D	17	1.600	40.64	1.800	45.72	1.956	49.68
ECC18D	18	1.700	43.18	1.900	48.26	2.056	52.22
ECC19D	19	1.800	45.72	2.000	50.80	2.156	54.76
ECC20D	20	1.900	48.26	2.100	53.34	2.256	57.30
ECC21D	21	2.000	50.80	2.200	55.88	2.356	59.84
ECC22D	22	2.100	53.34	2.300	58.42	2.456	62.38
ECC23D	23	2.200	55.88	2.400	60.96	2.556	64.92
ECC24D	24	2.300	58.42	2.500	63.50	2.656	67.46
ECC25D	25	2.400	60.96	2.600	66.04	2.756	70.00
ECC26D	26	2.500	63.50	2.700	68.58	2.856	72.54
ECC27D	27	2.600	66.04	2.800	71.12	2.956	75.08
ECC28D	28	2.700	68.58	2.900	73.66	3.056	77.62
ECC29D	29	2.800	71.12	3.000	76.20	3.156	80.16
ECC30D	30	2.900	73.66	3.100	78.74	3.256	82.70
ECC31D	31	3.000	76.20	3.200	81.28	3.356	85.24
ECC32D	32	3.100	78.74	3.300	83.82	3.456	87.78
ECC33D	33	3.200	81.28	3.400	86.36	3.556	90.32
ECC34D	34	3.300	83.82	3.500	88.90	3.656	92.86
ECC35D	35	3.400	86.36	3.600	91.44	3.756	95.40
ECC36D	36	3.500	88.90	3.700	93.98	3.856	97.94
ECC37D	37	3.600	91.44	3.800	96.52	3.956	100.48
ECC38D	38	3.700	93.98	3.900	99.06	4.056	103.02
ECC39D	39	3.800	96.52	4.000	101.60	4.156	105.56
ECC40D	40	3.900	99.06	4.100	104.14	4.256	108.10
ECC41D	41	4.000	101.60	4.200	106.68	4.356	110.64
ECC42D	42	4.100	104.14	4.300	109.22	4.456	113.18
ECC43D	43	4.200	106.68	4.400	111.76	4.556	115.72
ECC44D	44	4.300	109.22	4.500	114.30	4.656	118.26
ECC45D	45	4.400	111.76	4.600	116.84	4.756	120.80
ECC46D	46	4.500	114.30	4.700	119.38	4.856	123.34
ECC47D	47	4.600	116.84	4.800	121.92	4.956	125.88
ECC48D	48	4.700	119.38	4.900	124.46	5.056	128.42
ECC49D	49	4.800	121.92	5.000	127.00	5.156	130.96
ECC50D	50	4.900	124.46	5.100	129.54	5.256	133.50
ECC51D	51	5.000	127.00	5.200	132.08	5.356	136.04
ECC52D	52	5.100	129.54	5.300	134.62	5.456	138.58
ECC53D	53	5.200	132.08	5.400	137.16	5.556	141.12
ECC54D	54	5.300	134.62	5.500	139.70	5.656	143.66
ECC55D	55	5.400	137.16	5.600	142.24	5.756	146.20
ECC56D	56	5.500	139.70	5.700	144.78	5.856	148.74
ECC57D	57	5.600	142.24	5.800	147.32	5.956	151.28
ECC58D	58	5.700	144.78	5.900	149.86	6.056	153.82
ECC59D	59	5.800	147.32	6.000	152.40	6.156	156.36
ECC60D	60	5.900	149.86	6.100	154.94	6.256	158.90

### PART NUMBER CODING

ECC \_ \_ D \_ \_ -S1136

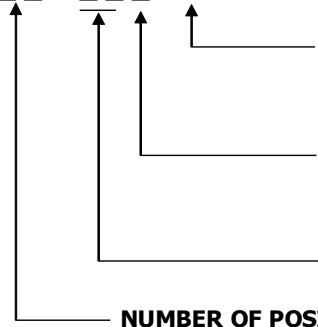

**MODIFICATION**  
 OMIT FOR STANDARD  
 S1136 = WITH SCOOPS (SEE PAGE 3 AND 4)

**MOUNTING STYLE**  
 N = NO MOUNTING

**TERMINATION**  
 JB = NO STANDOFF, .190 TAIL LENGTH (SEE PAGE 2)  
 JC = NO STANDOFF, .625 TAIL LENGTH (SEE PAGE 2)  
 JW = WITH STANDOFF, .190 TAIL LENGTH (SEE PAGE 1)  
 JX = WITH STANDOFF, .565 TAIL LENGTH (SEE PAGE 1)

## CUSTOMER COPY



RoHS COMPLIANT

UNLESS OTHERWISE SPECIFIED: DIMENSIONS ARE IN INCHES (MM)		DRAWN	DATE	NAME	
			05/04/06	MNH	
TOLERANCES: ANGULAR: ± 1° DECIMALS .XX = ± .02 [5] .XXX = ± .005 [13] .XXXX = ± .0005 [013]					THE INFORMATION HEREIN CONTAINS PROPRIETARY INFORMATION OF SULLINS ELECTRONICS AND IS NOT TO BE REPRODUCED, USED OR DISCLOSED TO OTHERS FOR ANY PURPOSE EXCEPT AS SPECIFICALLY AUTHORIZED IN WRITING BY AN OFFICER OF SULLINS ELECTRONICS.
TITLE EDGE CARD, .100 CC PRESS FIT PART NUMBER ECC _ _ DJ _ _ (-S1136)					
SIZE	CAGE CODE	DWG. NO.	REV		
C	54453	C10713	G		
SCALE: 3:1			SHEET 5 OF 5		