

# IL4622-01

## Isolated RS-485/RS-422 Transceiver with Integrated DC-DC Converter Evaluation Board

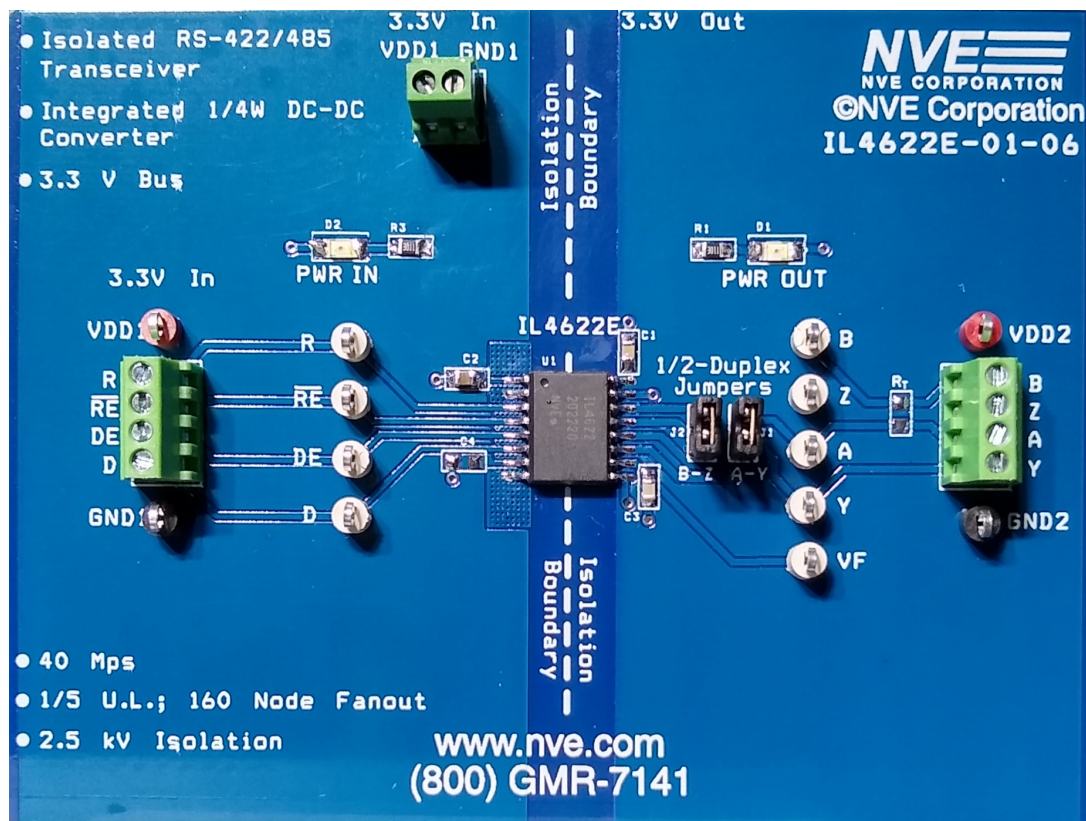

Board No.: IL4622-01

# About This Evaluation Board

This Evaluation Board implements a complete isolated RS-485 or RS-422 node using the IL4622 isolated transceiver with integrated isolated DC-DC convertor.

The 4 by 3 inch (100 x 75 mm) board provides uses a 2s2p board with thermal vias for optimal thermal performance. There are test points for checking voltages and waveforms. Jumpers allow the board to be used as full duplex (A/B bus receiver connections separated from the Y/Z bus driver connections), or half duplex (“A” jumpered to “Y” and “B” jumpered to “Z”).

The IL4622 is a high-speed, fully-isolated, full duplex differential bus transceiver with an integrated 3.3-to-3.3 volt DC-DC convertor to provide a fully-isolated 3.3 volt bus supply using the controller supply. This level of integration dramatically reduces chip count and board area.

The device uses NVE’s proven spintronic Giant Magnetoresistance (GMR) isolation technology and IsoLoop® high-efficiency micro-scale isolation transformers.

A unique ceramic/polymer composite barrier provides full isolation and virtually unlimited barrier life. Frequency hopping and shielding minimize EMI. Current limiting and thermal shutdown features protect against RS-485 short circuits and bus contention that may cause excessive power dissipation.

Bus inputs feature a “fail-safe if open” design, ensuring a logic high R-output if A/B are floating.

## IL4622 Specification Highlights

- 3.3 V bus
- Integrated ¼ W 3.3-to-3.3 V DC-DC convertor
- 40 Mbps RS-485 / RS-422 transceiver
- 1/5 Unit Load
- 2500 V<sub>RMS</sub> isolation voltage
- Up to 16.5 kV bus ESD protection
- Overcurrent and thermal shutdown protection
- -40 °C to +85 °C temperature range
- ANSI RS-485, ISO 8482:1987(E), and PROFIBUS compliant
- Low EMI without ferrite beads
- 0.3" True 8™ mm 16-pin SOIC package

Visit [www.nve.com](http://www.nve.com) for datasheets and reference circuits.

# Quick Start

- Connect  $V_{DD1}$  to a 3.3 V power supply.
- The two LEDs should indicate input and output power.
- Leave the jumpers in place for half-duplex RS-485.
- Connect a square-wave signal to the “D” input with an amplitude of 2.4 to 3.3 V.
- Look for the complementary “Y” and “Z” outputs on an oscilloscope.

# Circuit Diagram

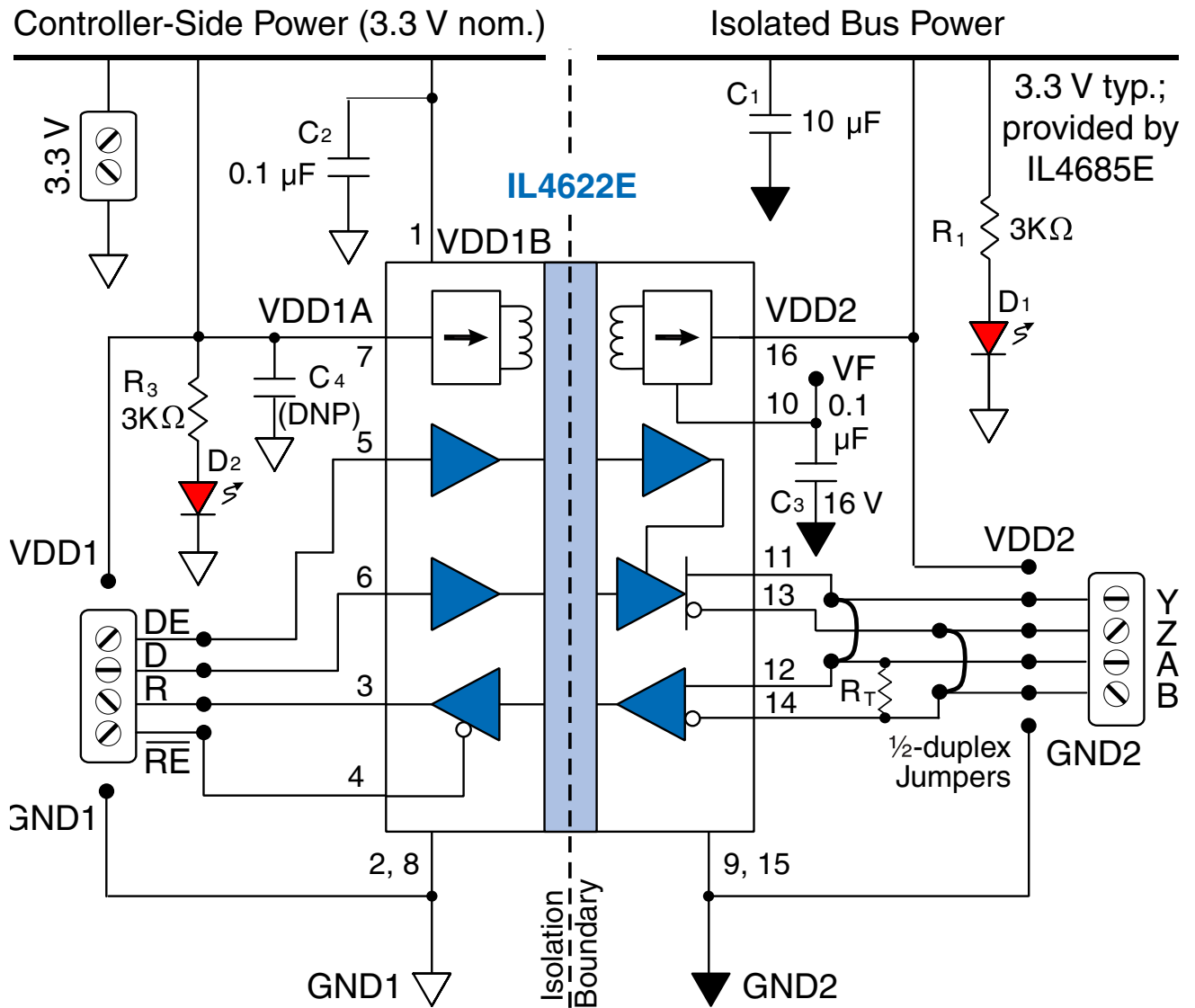

# Evaluation Board Layout

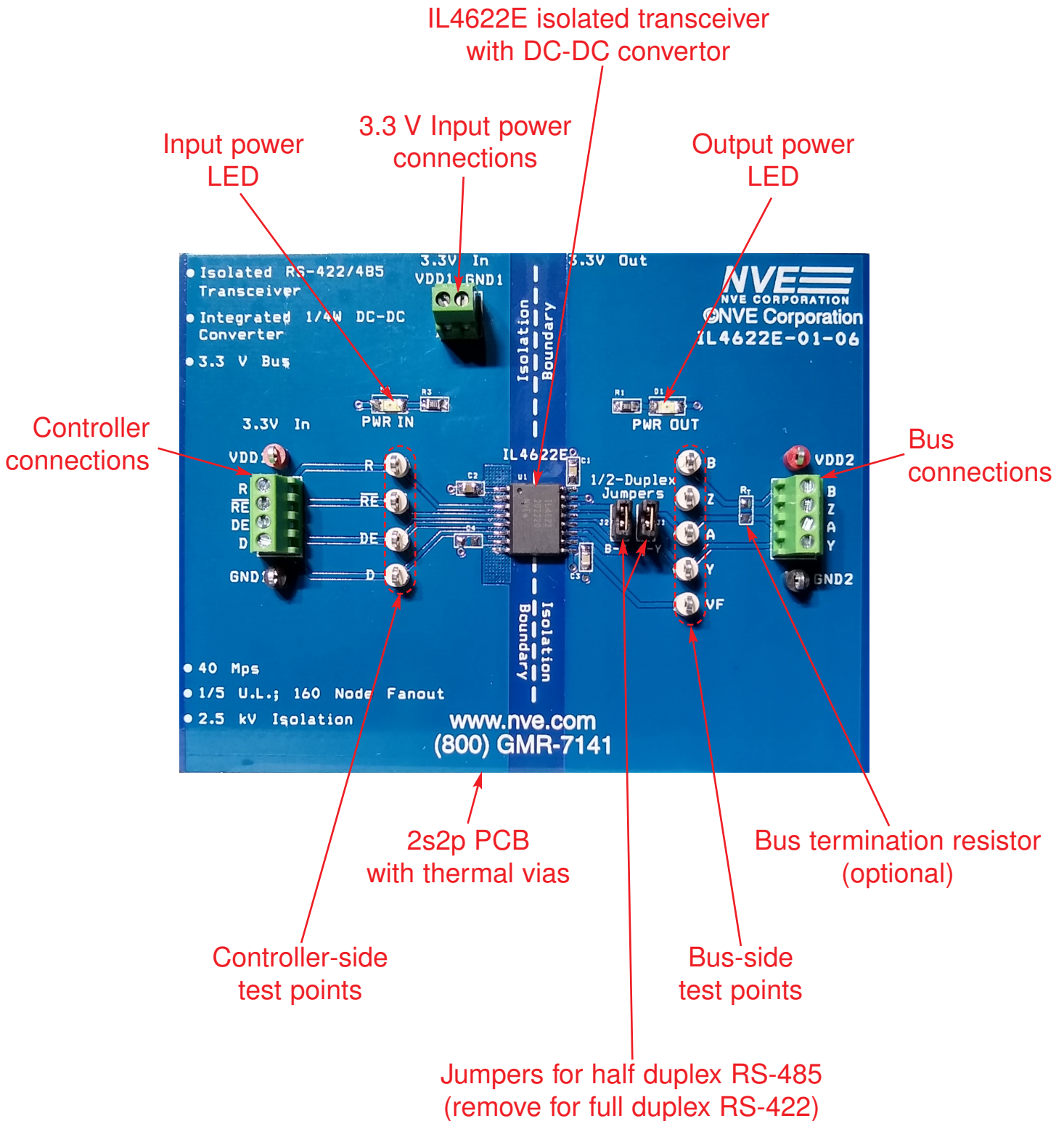

# Evaluation Board Layers

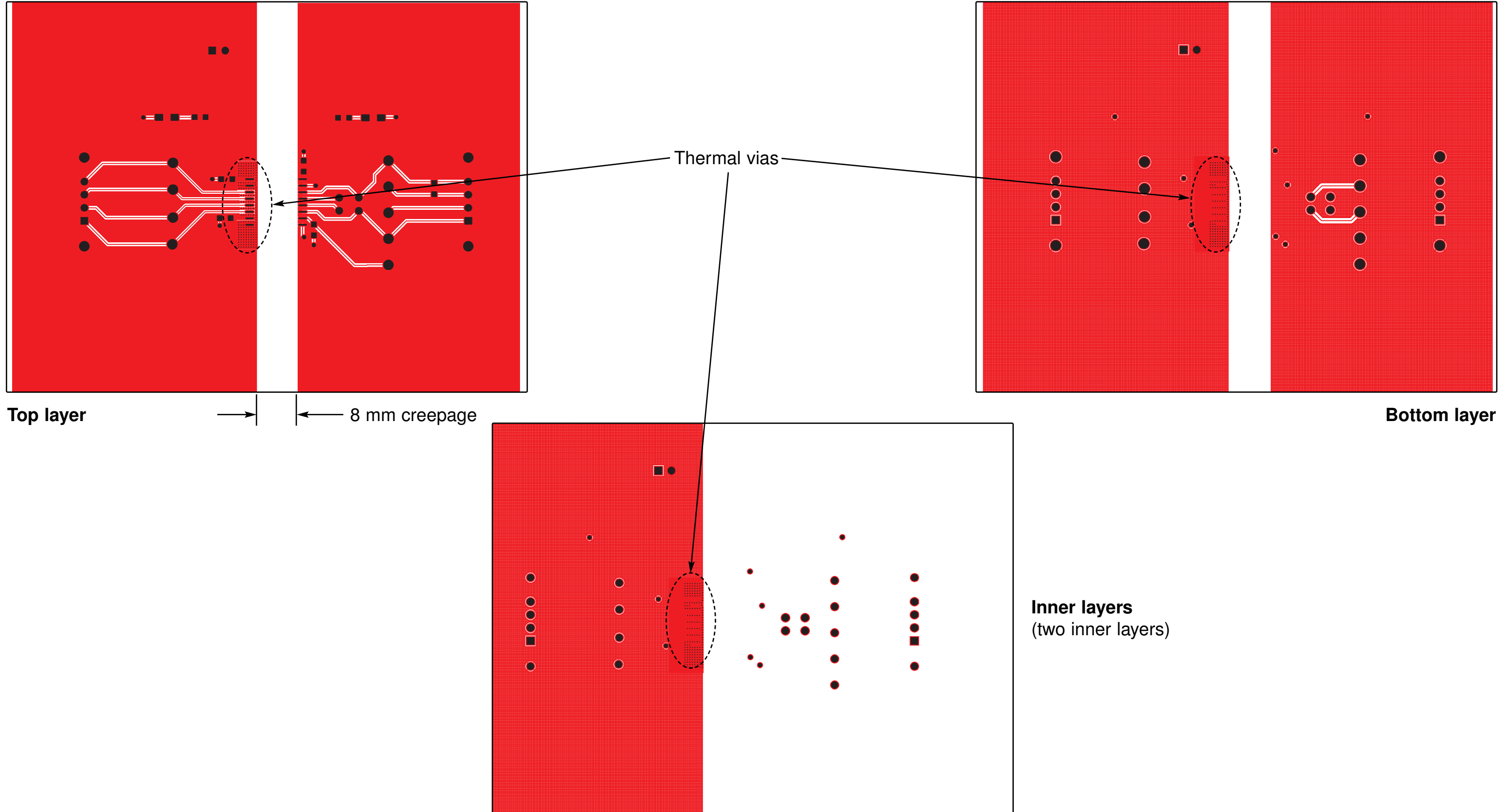

# Evaluation Board BOM and IL4622E Pinout

Reference	Manufacturer	Part Number	Description
U1	NVE Corporation	IL4622E	3.3 V RS-422 Xcvr w/ DC-DC Convertor
D1, D2	Kingbright	APT3216LSECK	LED CLEAR CHIP 2SMD
R1, R3	TE Connectivity Passive	CRG0805F3K0	RES SMD 3K OHM 1% 1/8W 0805
R2	DNP		Termination Resistor (optional)
C1, C3	Samsung Electro-Mech	CL21B104MBCNNNC	CAP CER 0.1UF 50V X7R 0805
C4	DNP		Alternate bypass capacitor location
C2	Taiyo Yuden	LMK212AB7106MG-T	CAP CER 10UF 10V X7R 0805
J1	TE Connectivity	282834-2	TERM BLK 2P SIDE ENT 2.54MM PCB
J2, J3	TE Connectivity	282834-4	TERM BLK 4P SIDE ENT 2.54MM PCB
	Keystone Electronics	500x	PC TEST POINT COMPACT

IL4622 pin	Symbol	Description
1	VDD1B	Transceiver controller-side power supply input (3.3 V nominal).
2	GND1	Input power supply ground (pin 2 is internally connected to pin 8).
3	R	Output data from bus.
4	$\overline{RE}$	Read data enable (R=high impedance if $\overline{RE}$ is high).
5	DE	Drive enable.
6	D	Data input to bus.
7	VDD1A	DC-DC convertor input voltage (3.3 V nominal). Bypass with 0.1 $\mu$ F.
8	GND1	Input power supply ground (pin 8 is internally connected to pin 2).
9	GND2	Output power supply ground (pin 9 is internally connected to pin 15).
10	VF	Output-side regulator input; connect to an external 0.1 $\mu$ F filter capacitor.
11	Y	Non-inverting bus driver.
12	A	Non-inverting bus receiver.
13	Z	Inverting bus driver.
14	B	Inverting bus receiver.
15	GND2	Output power supply ground (pin 15 is internally connected to pin 9).
16	VDD2	DC-DC convertor output (3.3 V typical); bypass with 10 $\mu$ F ceramic.

# Thermal Management

With a board full of functionality in a single IC, the IL4622 has a high power density. Care should be taken to ensure the die temperature does not exceed its 140 °C maximum operating temperature. Here are some thermal management tips.

## **Board Layout**

A double sided, double buried power plane (“2s2p”) board like the one in this kit maximizes thermal performance. Thermal vias should be used between the power plane and the board surfaces on the Controller side. All four IC ground pins should be connected to cool the leadframe.

## **Use Low-Power, Fractional-Load Transceivers**

Transceivers such as the NVE IL3685P are fractional load to minimize the drive current required by transmitting nodes and, if powered by the IL46xx, uses less bus power than other transceivers.

## **Avoid Termination Resistors with Shorter Bus Cables**

Termination resistors minimize reflections, which can be important for long cable lengths. However, these resistors significantly increase output drive current and may not be necessary with short bus cables.

## **Full Duplex Uses Less Power**

Full-duplex RS-422 buses have only one transmitter per bus and therefore only need one termination resistor, typically 120 Ω. Half-duplex RS-485 networks with long cables, however, are generally terminated on both ends because either end can receive data. This doubles the power dissipated in the termination resistors.

## **No External "Fail-Safe" Resistors**

The transceivers have internal "fail-safe" resistors, so external "fail-safe" pull-up and pull-down bias resistors are often unnecessary, and use power.

## **Minimize Data Rate**

The transceiver draws more power at higher frequency, so the data rate should not be higher than necessary to minimize transceiver power.

## **Limit Transmission Time**

The transceivers use less power receiving than transmitting, and much less if there are termination resistors. Average power dissipation can be reduced considerably by disabling the driver (DE = LOW) when not transmitting data.



# Application Information

## Simple Capacitive Decoupling

The only external parts required are a 0.1  $\mu\text{F}$  ceramic capacitor placed as close as possible to the VDD1B supply pin, a 10  $\mu\text{F}$  ceramic capacitor for the VDD2B pin, and a 0.1  $\mu\text{F}$  filter capacitor. This low external parts count reduces board area and cost.

## Thermal Shutdown

The IL4622E's bus driver is disabled when the driver die temperature exceeds approximately 150 °C, and re-enabled when the die temperature drops below approximately 135 °C. The receiver and DC-DC convertor sections continue to operate during thermal shutdown.

## Inherently Low EMI

IL4622E Transceivers are fully compliant with generic EMC standards EN50081, EN50082-1 and the umbrella line-voltage standard for Information Technology Equipment (ITE) EN61000.

The DC-DC convertor oscillator operates above 88 MHz, where emission limits are higher since there is less risk of interference with common commercial radio and television broadcasting.

Frequency-hopping technology dramatically reduces peak EMI, and synchronous rectification and PWM control are avoided, resulting in inherently low EMI. Ferrite beads are generally not required for EMI mitigation.

## High Magnetic Immunity

The Isolator's Wheatstone bridge configuration and differential magnetic field signaling ensure excellent EMC performance against all relevant standards.

## Driver Features

Unlike most other transceivers, IL4622E transceivers meet stringent PROFIBUS standards for maximum differential output voltage. The driver features low propagation delay skew to maximize bit width and minimize EMI. Drivers have tri-state capability via the active-high DE input.

## Internal Fail-Safe Biasing Resistors

Internal "fail-safe biasing" forces a logic high state on "R" with an open-circuit between the bus "A" and "B" lines, or when no drivers are active on the bus.

# Isolated RS485 / RS422 Transceivers

NVE offers a wide choice of isolated RS-485 and RS-422 network transceivers in addition to the IL4622 used in this board.

Versions are available in 0.15-inch and 0.3-inch SOIC packages, as well as ultraminiature QSOP packages. QSOP and 0.15-inch SOIC package are the most compact solutions in the world.

Standard isolation voltage is 2.5 kV<sub>RMS</sub>, and ultrahigh-voltage V-Series versions have 6 kV<sub>RMS</sub> isolation voltage.

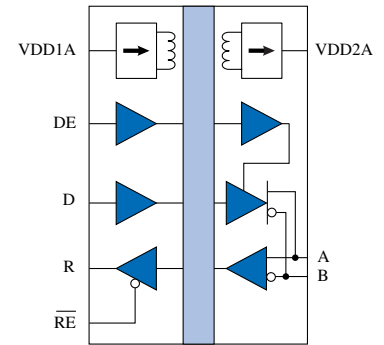

**IL4685**

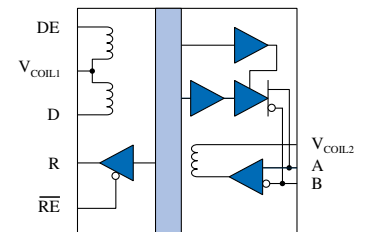

**IL3185 / IL3285 / IL3485**

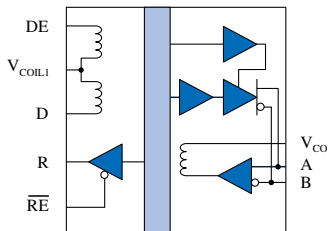

**IL3122 / IL3222 / IL3422**

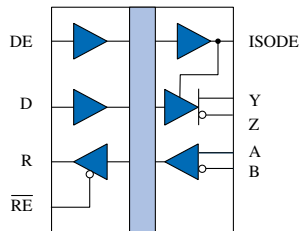

**IL422 / IL3022 / IL3522**

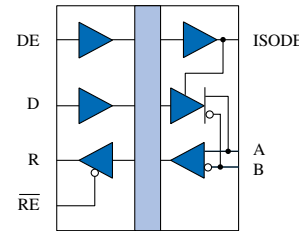

**IL485 / IL3085 / IL3585 /  
IL3685 / IL3685P**

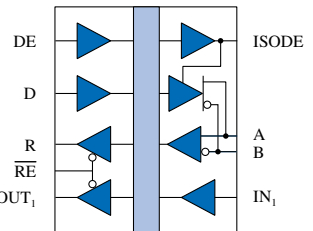

**IL485W**

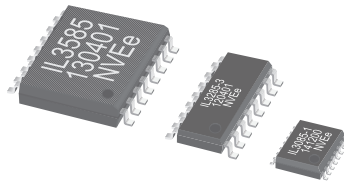

Model	Bus	Inputs	Mbps	Nodes	Bus ESD	Key Features	Available Packages
IL3122	RS-422	Passive	5	32	15 kV	Low Cost	0.15" SOIC16; 0.3" SOIC16
IL3185	RS-485	Passive	5	32	15 kV	Low Cost	0.15" SOIC16; 0.3" SOIC16
IL3222	RS-422	Passive	5	256	15 kV	1/8 Unit Load	0.15" SOIC16; 0.3" SOIC16
IL3285	RS-485	Passive	5	256	15 kV	1/8 Unit Load	0.15" SOIC16; 0.3" SOIC16
IL3422	RS-422	Passive	20	32	15 kV	High Speed	0.15" SOIC16; 0.3" SOIC16
IL3485	RS-485	Passive	20	32	15 kV	High Speed	0.15" SOIC16; 0.3" SOIC16
IL422	RS-422	Digital	25	32	15 kV	Legacy Standard	0.3" SOIC16
IL485	RS-485	Digital	35	32	2 kV	Legacy Standard	0.3" SOIC16
IL485W	RS-485	Digital	35	32	2 kV	Handshake Line	0.3" SOIC16
IL3022	RS-422	Digital	4	32	7.5 kV	Low Cost	0.3" SOIC16
IL2985	RS-485	Digital	4	32	15 kV	Low Power	0.3" SOIC16
IL3085	RS-485	Digital	4	32	15 kV	Low Cost	QSOP16; 0.15" SOIC16; 0.3" SOIC16
IL3522	RS-422	Digital	40	50	15 kV	Very High Speed	0.3" SOIC16
IL3585	RS-485	Digital	40	50	15 kV	Very High Speed	0.15" SOIC16; 0.3" SOIC16
IL3685	RS-485	Digital	40	50	15 kV	PROFIBUS	QSOP16; 0.15" SOIC16; 0.3" SOIC16
IL3685P	RS-485	Digital	40	160	16.5 kV	3.3 V bus; 1/5 U.L.	QSOP16; 0.3" SOIC16
IL4622	RS-422	Digital	40	160	12 kV	DC-DC Convertor	0.3" SOIC16
IL4685	RS-485	Digital	40	160	16.5 kV	DC-DC Convertor	0.3" SOIC16

### **Limited Warranty and Liability**

Information in this document is believed to be accurate and reliable. However, NVE does not give any representations or warranties, expressed or implied, as to the accuracy or completeness of such information and shall have no liability for the consequences of use of such information. In no event shall NVE be liable for any indirect, incidental, punitive, special or consequential damages (including, without limitation, lost profits, lost savings, business interruption, costs related to the removal or replacement of any products or rework charges) whether or not such damages are based on tort (including negligence), warranty, breach of contract or any other legal theory.

### **Right to Make Changes**

NVE reserves the right to make changes to information published in this document including, without limitation, specifications and product descriptions at any time and without notice.

### **Use in Life-Critical or Safety-Critical Applications**

Unless NVE and a customer explicitly agree otherwise in writing, NVE products are not designed, authorized or warranted to be suitable for use in life support, life-critical or safety-critical devices or equipment. NVE accepts no liability for inclusion or use of NVE products in such applications and such inclusion or use is at the customer's own risk. Should the customer use NVE products for such application whether authorized by NVE or not, the customer shall indemnify and hold NVE harmless against all claims and damages.

### **Applications**

Applications described in this document are illustrative only. NVE makes no representation or warranty that such applications will be suitable for the specified use without further testing or modification. Customers are responsible for the design and operation of their applications and products using NVE products, and NVE accepts no liability for any assistance with applications or customer product design. It is customer's sole responsibility to determine whether the NVE product is suitable and fit for the customer's applications and products planned, as well as for the planned application and use of customer's third party customers. Customers should provide appropriate design and operating safeguards to minimize the risks associated with their applications and products. NVE does not accept any liability related to any default, damage, costs or problem which is based on any weakness or default in the customer's applications or products, or the application or use by customer's third party customers. The customer is responsible for all necessary testing for the customer's applications and products using NVE products in order to avoid a default of the applications and the products or of the application or use by customer's third party customers. NVE accepts no liability in this respect.

## **An ISO 9001 Certified Company**

NVE Corporation  
11409 Valley View Road  
Eden Prairie, MN 55344-3617

©NVE Corporation

All rights are reserved. Reproduction in whole or in part is prohibited without the prior written consent of the copyright owner.

Manual No.: ISB-CB-021

July 2020