

CRS-240

180...280W SINGLE OUTPUT DC/DC CONVERTERS

GENERAL FEATURES:

- High input-output isolation
- Standard size Eurocard 3U
- Adjustable output voltage
- Remote sensing
- Input voltage OK LED
- Output voltage presence LED
- Remote inhibit
- Efficiency up to 92%



	12Vin 9 ... 15V	24Vin 18V ... 30V	48Vin 36V ... 72V	72Vin 50,4V ... 90V	110Vin 77V ... 144V	220Vin 165 ... 275V
5Vout	CRS-240-6351 180W	CRS-240-6355 180W	CRS-240-6359 180W	CRS-240-6363 180W	CRS-240-6367 180W	CRS-240-6371* 180W
12Vout	CRS-240-6352 180W	CRS-240-6356 240W	CRS-240-6360 240W	CRS-240-6364 240W	CRS-240-6368 240W	CRS-240-6372 240W
24Vout	CRS-240-6353 200W	CRS-240-6357 240W	CRS-240-6361 280W	CRS-240-6365 280W	CRS-240-6369 280W	CRS-240-6373 280W
48Vout	CRS-240-6354 200W	CRS-240-6358 240W	CRS-240-6362 280W	CRS-240-6366 280W	CRS-240-6370 280W	CRS-240-6374 280W

Several references are subjected to special MOQs and lead times. Please consult Premium's Sales Dept. and web site



INPUT	
Input voltage range	See table
Input undervoltage shutdown	55% to 60% V_i nom
Maximum allowed input ripple	15% V_{in} nom (EN50155)
OUTPUT	
Output voltage	See table
Output voltage adjustment	-10% ... +15% V_o nom
Line regulation ($I_o = \text{nom}$)	< 0,2 % ($I_o = \text{nom}$)
Load regulation ($V_{in} = \text{nom}$)	< 0,2 % ($V_{in} = \text{nom}$; I_o : 0...100%)
Ripple	< 50 mVpp
Noise (BW = 20MHz)	< 100 mVpp
ENVIRONMENTAL	
Storage temperature	-40°C ... 85°C
Operating temperature range at $I_o = 100\%$	-25°C ... 60°C (-40°C ... 60°C, see note-1)
Operating temperature range at $I_o = 50\%$	-25°C ... 80°C (-40°C ... 80°C, see note-1)
Maximum Relative humidity	95% with no condensation
MTBF	400.000h @ 40°C according to IEC61709
EMC	
Emission	EN61000-6-3
Immunity	EN61000-6-2
SAFETY	
Safety	EN60950-1, EN62368-1
Dielectric strength Input-Output	3000Vac, 4200Vdc 1min.
Dielectric strength Input-GND	1500Vac, 2100Vdc 1min.
Dielectric strength Output-GND	1500Vac, 2100Vdc 1min.
MECHANICAL	
Approximate weight	640g
Dimensions	100 x 220 x 38.5mm
CONTROL	
Remote inhibit range	5V ... 24V
Remote sense	< 0.3V per pole
PROTECTIONS	
Against overloads and short-circuits	Current limiting
Against reverse input voltage.	Input fuse
Against input under-voltage.	Under-voltage lock-out
Against Input over-currents	Input fuse

Note-1: The unit can start up and work at an ambient temperature of -40°C with the following restrictions:

- Do not handle the connection terminals below -25°C
- The output ripple can rise up to 150mVpp at -40°C

ORDERING CODES

Part Number	Power [W]	Input [V]	Input range [V]	Output [V]	Output current [A]	Efficiency [%]
CRS-240-6351	180	12	9 - 15	5	36	79
CRS-240-6352	180	12	9 - 15	12	15	80
CRS-240-6353	200	12	9 - 15	24	8,33	82
CRS-240-6354	200	12	9 - 15	48	4,17	82
CRS-240-6355	180	24	18 - 30	5	36	80
CRS-240-6356	240	24	18 - 30	12	20	83
CRS-240-6357	240	24	18 - 30	24	10	87
CRS-240-6358	240	24	18 - 30	48	5	88
CRS-240-6359	180	48	36 - 72	5	36	80
CRS-240-6360	240	48	36 - 72	12	20	84
CRS-240-6361	280	48	36 - 72	24	11,7	88
CRS-240-6362	280	48	36 - 72	48	5,8	89
CRS-240-6363	180	72	50,4 - 90	5	36	81
CRS-240-6364	240	72	50,4 - 90	12	20	88
CRS-240-6365	280	72	50,4 - 90	24	11,7	90
CRS-240-6366	280	72	50,4 - 90	48	5,8	90
CRS-240-6367	180	110	77 - 144	5	36	81
CRS-240-6368	240	110	77 - 144	12	20	88
CRS-240-6369	280	110	77 - 144	24	11,7	91
CRS-240-6370	280	110	77 - 144	48	5,8	92
CRS-240-6371*	180	220	165 - 275	5	36	81
CRS-240-6372	240	220	165 - 275	12	20	88
CRS-240-6373	280	220	165 - 275	24	11,7	91
CRS-240-6374	280	220	165 - 275	48	5,8	92

Several references are subjected to special MOQs and lead times. Please consult Premium's Sales Dept. and web site.

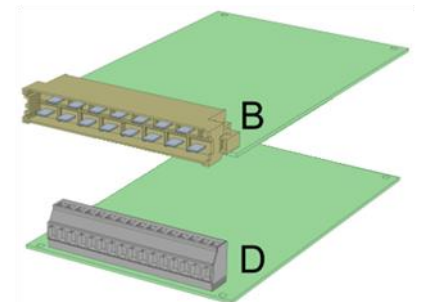
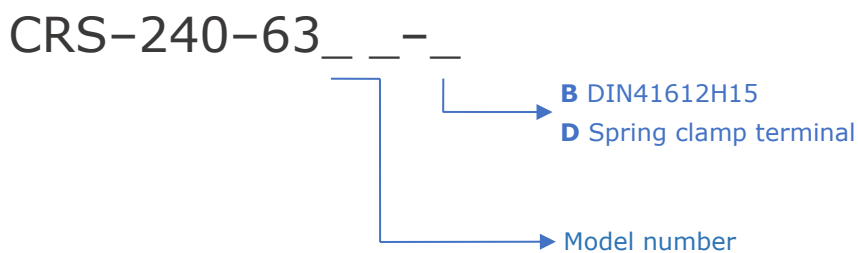

Accessories must be ordered in a separated order line

BLOCKS DIAGRAM

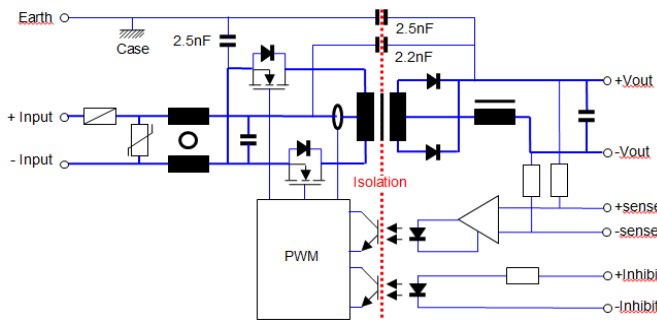

CONNECTIONS

Connector DIN41612H15 (Max. 12A / terminal)

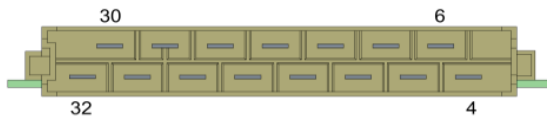

Spring clamp terminals (Max. 12A / terminal)

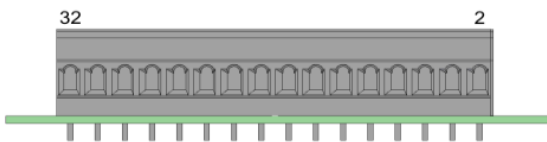

Pin out	
+Input	8,10
-Input	4,6, (2)
Earth	16
+Output	26,28,30
-Output	20,22,24
+Sense	32
-Sense	18
+Inhibit	14
-Inhibit	12

TYPICAL OUTPUT CHARACTERISTIC

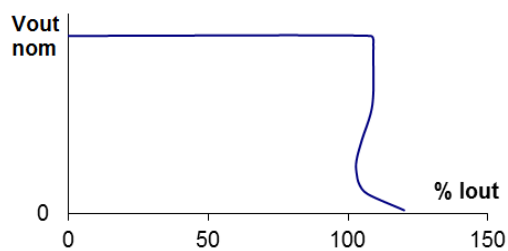

POWER DERATING vs AMBIENT TEMP.

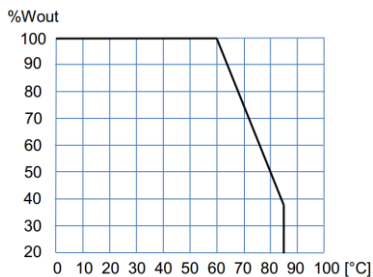

DESCRIPTION

The CRS-240 series consists of DC-DC converters, with a galvanic isolation between input and output. The converters operate at a fixed switching frequency and use push-pull converter topology.

For maximum regulation, the remote sensing terminals can be connected to the load. This will allow a power cable voltage drop of up to 0.3 V on each cable to be offset.

The device is protected against overload and short-circuits by means of a current limiting circuit. The device is also protected against reverse polarity input voltage, and the input fuse blows if an improper connection is made.

When a converter input undervoltage condition occurs, the converter is disabled, thus preventing the battery from becoming totally discharged. Once the input is within the range the unit restarts automatically.

INSTALLATION

There are two connecting options:

- DIN-41612-H15 connector
- Spring clamp terminals

The product can be mounted in several ways:

- On a chassis by means of the 4 corner holes.
- In EUROCARD racks. For this application there is a standard 9Te front plate accessory reference **NP-9155**
- With the base reference **NP-9125**. This accessory can be mounted on a chassis or in DIN rail adding the clip accessory **NP-9135**.

START-UP

Perform connection as per the table. Use of remote sensing is not absolutely necessary, but if this is required, use of a co-axial or a twisted-pair cable is recommended.

WARNING: If the load is connected to the tabs of remote sensing (+/-S) and the connection from the output to this load is missing the remote sensing function could make unusable due to the acting of the internal fuse of protection.

If power levels close to the maximum output are required, make sure the assembly enhances cooling by natural convection and the card is placed in vertical position.

If several converters need to be connected in parallel, do the following:

Set the output voltage for all converters featuring a mutual difference as small as possible. Join the load outputs by using cables with a cross-section no greater than the one required and of equal length.

Do not use remote sensing.

For safety reasons, the following requirements must be complied with:

Provide the equipment with protective enclosure that complies with the electrical safety directives in effect within the country where the equipment is installed. Only replace the fuse with another fuse of the same rating and type, and only after disconnecting the converter from DC power.



DIMENSIONS

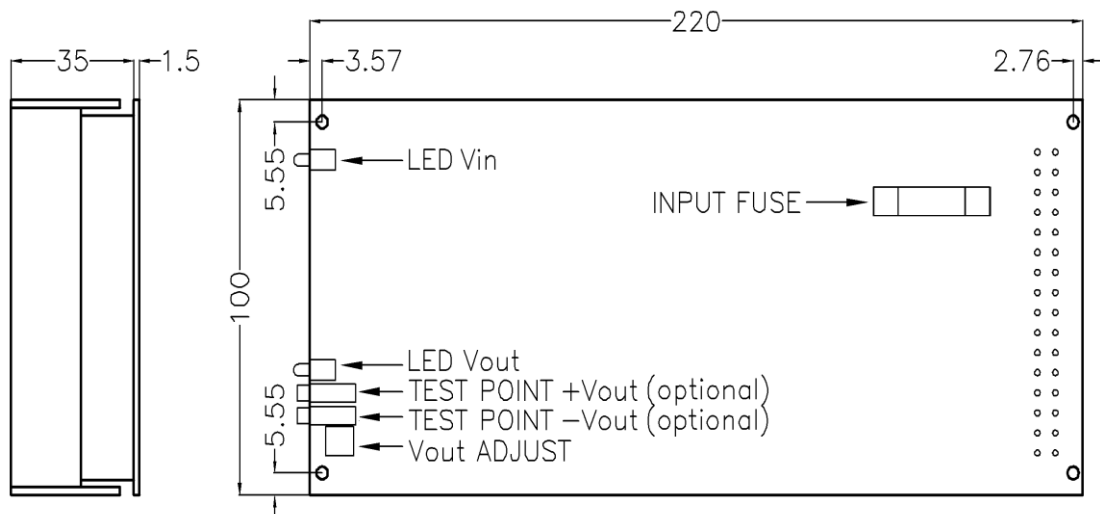

ACCESSORIES

ACCESSORIES	CODE
Rack 19" frontal panel (3U 9TE)	NP-9155
Mounting base	NP-9125
Din rail clip for mounting base	NP-9135
Redundant connection for two units (ORing diodes + alarms contacts)	ACD-15, ACD-25

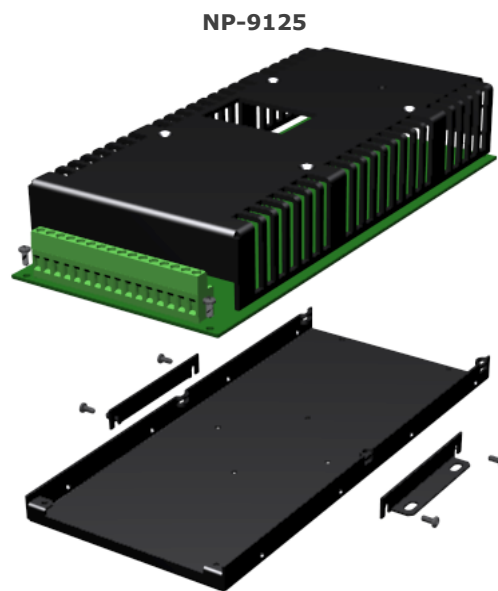
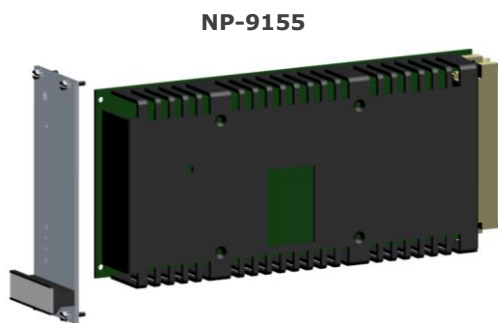



CE|UK CA EU, UKCA DECLARATION OF CONFORMITY

The undersigned, representing the following:

Manufacturer: PREMIUM, S. A.,
Address: C/ Dolors Aleu 19-21, 08908 L'Hospitalet de Llobregat, SPAIN

herewith declares that the product:

Type: DC/DC converter
Models: **CRS-240-6351 ... 6374**

is in conformity with the provisions of the following EU directive(s):

2014/35/EU SI 2016 No 1101	Low voltage / The electrical equipment (safety) regulations
2014/30/EU SI 2016 No 1091	EMC / Electromagnetic compatibility regulations
2011/65/EU Annex II and its amendment 2015/863/EU SI 2012 No. 3032	RoHS / Restriction of the use of certain hazardous substances in electrical and electronic equipment

and that standards and/or technical specifications referenced below have been applied:

EN 60950-1: 2005	Safety. Information technology equipment
EN 62368-1: 2014	Safety. Audio/video information and communication technology equipment
EN 61000-6-3: 2007	Generic emission standard
EN 61000-6-2: 2005	Generic immunity standard

CE marking year: **2002**; UKCA marking year: **2021**

Notes:

For the fulfillment of this declaration the product must be used only for the aim that has been conceived, considering the limitations established in the instructions manual or datasheet.

L'Hospitalet de Llobregat, 31-05-2019

Albert Sole
Technical Director

PREMIUM S.A. is an ISO9001 and ISO14001
certified company by **Bureau Veritas**