

SPECIFICATIONS:

MATERIALS:
 INSULATOR: GLASS-FILLED NYLON THERMOPLASTIC, UL94 V-0
 PROCESS TEMP: 260°C
 CONTACTS: GOLD PLATED BRASS
 SHELL: NICKEL PLATED STEEL
 SEALING MATERIAL: F08 FLEXIBLE ADHESIVE

ELECTRICAL:
 RATED CURRENT: 5A
 WORKING VOLTAGE: 250VAC
 INSULATION RESISTANCE: 1000 MOhms MIN.
 CONTACT RESISTANCE: 15 mOhms MAX.

ENVIRONMENT:
 OPERATING TEMPERATURE: -55°C TO +125°C

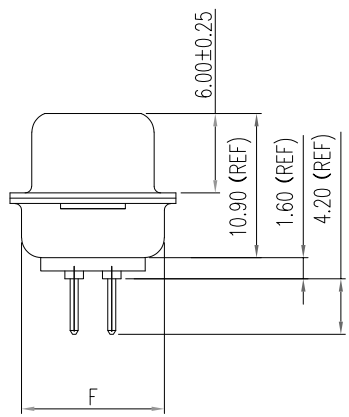
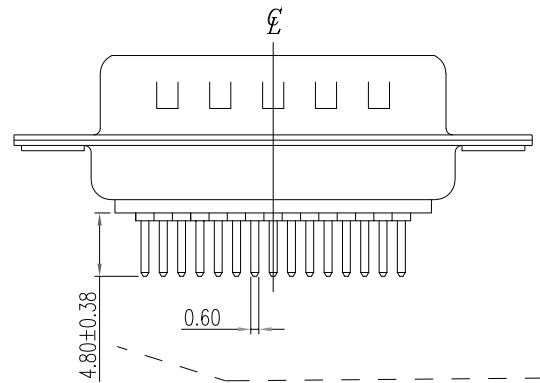
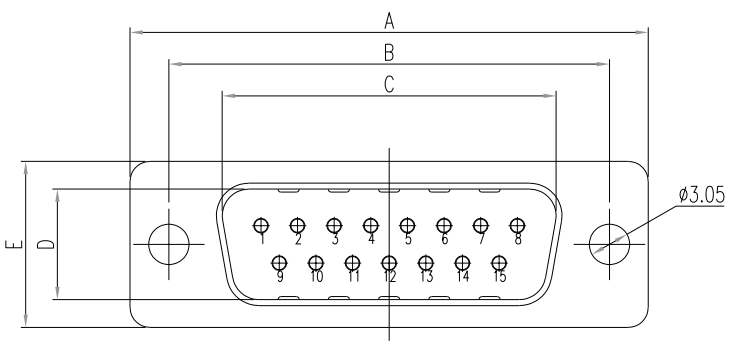

MEETS IP67 STANDARDS
 (SEE PAGE 3 FOR SEALING DETAILS)

772-EYY-113RYY1

SERIES
 POSITIONS
 09
 15
 25
 GENDER
 1 = MALE
 CONTACT LENGTH
 1 = 4.80mm TAILS
 C = 6.30mm TAILS
 D = 10.00mm TAILS
 SHELL PLATING
 3 = NICKEL (GROUND INDENTS)
 HARDWARE OPTIONS
 00 = NO HARDWARE
 01 = 0.098" 4-40 INSERT, BOARD SIDE
 05 = 0.237" 4-40 BOARD LOCK, BOARD SIDE
 PLATING OPTIONS
 1 = GOLD FLASH
 2 = 30u" GOLD

DIMENSIONS(mm)						
SIZE	A ^{+0.39} _{-0.39}	B ^{+0.25} _{-0.25}	C ^{+0.25} _{-0.25}	D ^{+0.25} _{-0.34}	E ^{+0.38} _{-0.38}	F ^{+0.25} _{-0.25}
9	30.81	24.99	16.92	8.36	12.55	10.80
15	39.19	33.32	25.25	8.36	12.55	10.80
25	53.04	47.04	38.96	8.36	12.55	10.80
37	69.32	63.50	55.42	8.36	12.55	10.80
50	67.00	61.10	52.80	11.26	15.40	13.30

RoHS COMPLIANT

UNITS = mm

DO NOT SCALE FROM DRAWING



THESE DRAWINGS AND SPECIFICATIONS ARE THE PROPERTY OF NorComp AND SHALL NOT BE REPRODUCED, COPIED OR USED AS THE BASIS FOR THE MANUFACTURE OR SALE OF APPARATUS WITHOUT WRITTEN PERMISSION.

DRAWN:
P. JENKINS
 DATE:
09/18/2008

NorComp

SCALE: NTS	SHEET 1	OF 3	REV 12
DWG NO. 772-EYY-113RYY1			

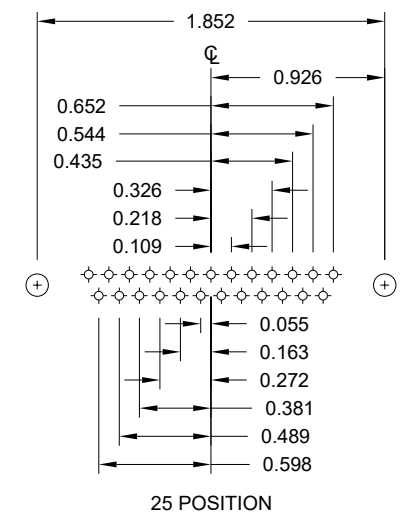
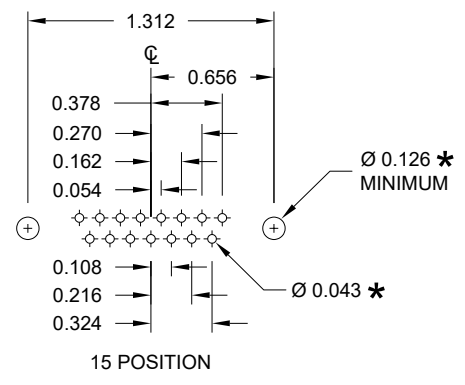
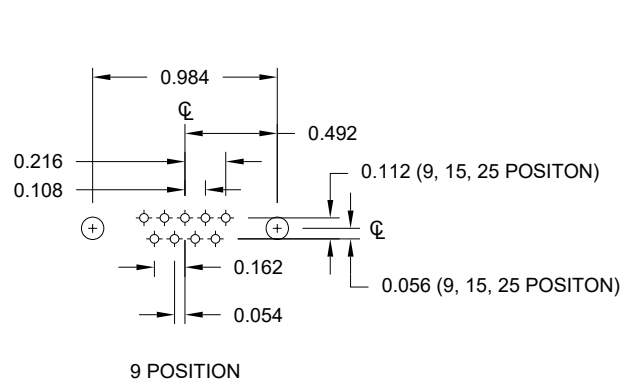

* TYP. SUGGESTED SIZE
MAY NOT BE SUITABLE FOR ALL APPLICATIONS

RoHS COMPLIANT

UNITS = inch

DO NOT SCALE FROM DRAWING



THESE DRAWINGS AND SPECIFICATIONS ARE THE PROPERTY OF NorComp AND SHALL NOT BE REPRODUCED, COPIED OR USED AS THE BASIS FOR THE MANUFACTURE OR SALE OF APPARATUS WITHOUT WRITTEN PERMISSION.

DRAWN:
P. JENKINS
DATE:
09/18/2008

NorComp

SCALE: NTS	SHEET 2	OF 3	REV 12
DWG NO.		772-EYY-113RYY1	

SEALING PROCESS

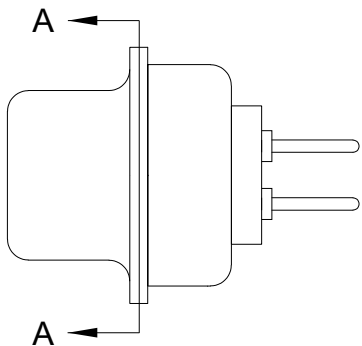

FRONT SEAL APPLIED OVER INSULATOR AND BETWEEN FRONT & REAR SHELLS

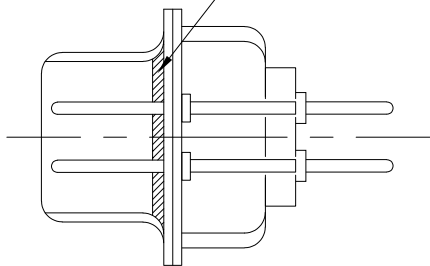

DETAIL A-A

HARDWARE OPTION

ALL CLINCH-NUTS ARE 4-40 INTERNAL THREADS

01X 0.098" (BOARD SIDE)

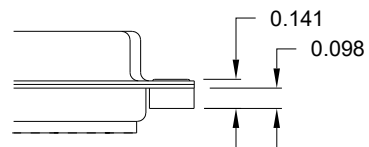

05X 0.237" (BOARD SIDE)

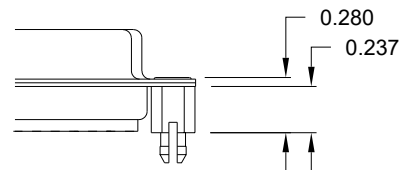

RoHS COMPLIANT



THESE DRAWINGS AND SPECIFICATIONS ARE THE PROPERTY OF NorComp AND SHALL NOT BE REPRODUCED, COPIED OR USED AS THE BASIS FOR THE MANUFACTURE OR SALE OF APPARATUS WITHOUT WRITTEN PERMISSION.

DRAWN:
P. JENKINS

DATE:
09/18/2008

UNITS = inch

DO NOT SCALE FROM DRAWING

NorComp

SCALE:
NTS

SHEET 3 OF 3

REV 12

DWG NO.

772-EYY-113RYY1