

Features

HIGH CURRENT CARRY AND HIGH VOLTAGE

Inert gas filled arc chamber suitable for high voltage switching

COMPACT STRUCTURE, LOW NOISE

Small, low-profile design with low noise while carrying or switching loads

COIL ECONOMIZER

Economized coil for low power consumption

SAFE FOR EXPLOSIVE ENVIRONMENTS

No arc leakage due to a hermetically sealed design

HIGH RELIABILITY DESIGN

Hermetic sealing creates a stable environment for high voltage switching

NO SPECIFIC MOUNTING ARRANGEMENT

Mountable in any orientation without reduction of performance

VARIOUS APPLICATIONS

Battery disconnect, EV charging, energy storage systems, photovoltaics, power control, circuit protection and much more

Sealing Type: Epoxy/Resin

- ✓ Normally closed
- ✓ Side mount available
- ✓ Dual coil available
- ✓ Bi-directional options



Certification Information

1. Meet RoHS (2011/65/EU)
2. CE Certified
3. UL pending

Nomenclature

AREV250 - M AN

Series code:

"AREV250" = AREV250

Type Code:

Blank = Main Contacts (NO)
 "NC" = Main Contacts (NC)

Coil Voltage Code:

Standard Coils (w/Economizer):
 "M" = 12 - 24 V DC
 "F" = 48 VDC
 "G" = 48 - 72 VDC

Dual Coil Options:

"B" = 12 VDC, Internal Coil Suppression
 "C" = 24 VDC, Internal Coil Suppression
 "E" = 48 VDC, Internal Coil Suppression

Options:

Blank = Std. Options (Bottom Mount, Without Aux. Contact & Polarized Load Terminals)
 "A" = With Aux. Contact (SPST-NO)
 "B" = With Aux. Contact (SPST-NC)
 "C" = With Aux. Contact (SPDT)
 "N" = Non-Polar Load Terminals
 "S" = Side Mount

Product Data Sheet

MAIN CONTACT

Contact Arrangement	1 Form X (SPST-NO)	
Load Connection	M8 Thread Male	
Rated Load Voltage	12-900VDC	
Max Breaking Limit	2,000A @320VDC, 1 Cycle	
Dielectric Withstanding Voltage	Between Open Contacts	4000Vms, 1 min., < 1mA
	Between Contacts to Coil	2200Vms, 1 min., < 1mA
Insulation Resistance @ 500VDC	New: 100M Ω End of Life: 50M Ω	
Voltage Drop (200A)	≤60mV	

EXPECTED LIFE

Load Life (Resistor Load) 250A/450VDC	10,000 Cycles
Mechanical Life	200,000 cycles

AUX. CONTACT

Aux Contact Arrangement	1 From A
Aux Contact Current Max	2A @30VDC/3A @125VAC
Aux Contact Current Min	100mA@8V
Aux. Contact Resistance Max.	0.417ohms@30Vdc 0.150ohms@125Vac

ENVIRONMENTAL DATA

Shock	Functional	196m/s ² Sine half-wave pulse
	Destructive	490m/s ² Sine half-wave pulse
Operating Temperature	-40 to +85°C	
Altitude	<4000m	
Weight	0.95 Lb (0.43 kg)	

Short Time Overload Current

400A @85°C	Continuous
500A @40°C	2 Minutes
600A @40°C	10 Seconds

OPERATE TIME @ 25°C

Close (includes bounce)	30ms, Max.
Bounce (after close only)	5ms, Max.
Release (include arcing)	10ms, Max.

COIL DATA

Coil Code	M	F	G
Rated Voltage*	12-24VDC	48VDC	48-72VDC
Max Operate Voltage	36VDC	72VDC	80VDC
Pick-Up Voltage (20°C) Max.	9VDC	36VDC	36VDC
Pick-Up Voltage (20°C) Min.	6VDC	18VDC	18VDC
Coil Current (20°C @ Rated Voltage)	Inrush: 3.8A Holding: 0.13	Inrush: 1.3A Holding: 0.03A	Inrush: 1.3A Holding: 0.03A
Coil Power (20°C @ Rated Voltage)	2W	2W	2W
Max Pick-Up Voltage (85°C)	9.6VDC	38.4VDC	38.4VDC
Coil Resistance + 10% (20°C)	3.1 Ω	40 Ω	40 Ω

COIL DATA

Coil P/N Designation	B	C	E
Rated Voltage	12VDC	24VDC	48VDC
Coil Type	Dual	Dual	Dual
Coil Voltage, Max (V)	16VDC	32VDC	64VDC
Max. Pickup Voltage	8VDC	16VDC	40VDC
Min. Drop-out Voltage	0.5VDC	2VDC	4VDC
Pick-Up Current, Max (75 ms)	3.9A	1.6A	0.97A
Coil Current	0.23A	0.097A	0.042A
Coil Power	2.8W	2.3W	2W

Performance Data



Estimated Make & Break Power Switching Ratings

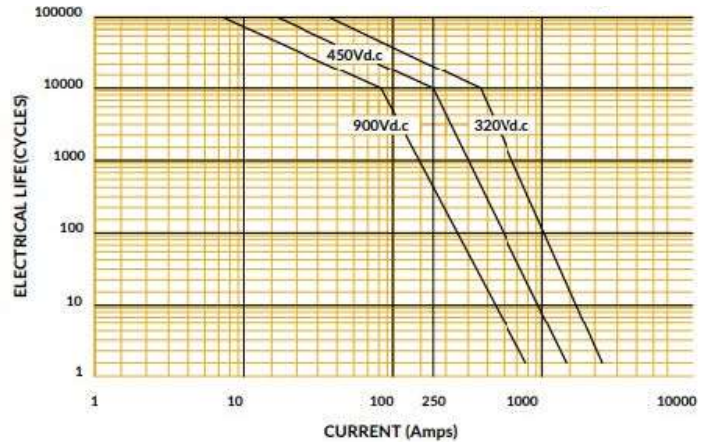

Outline Dimensions (mm)

Bottom Mount

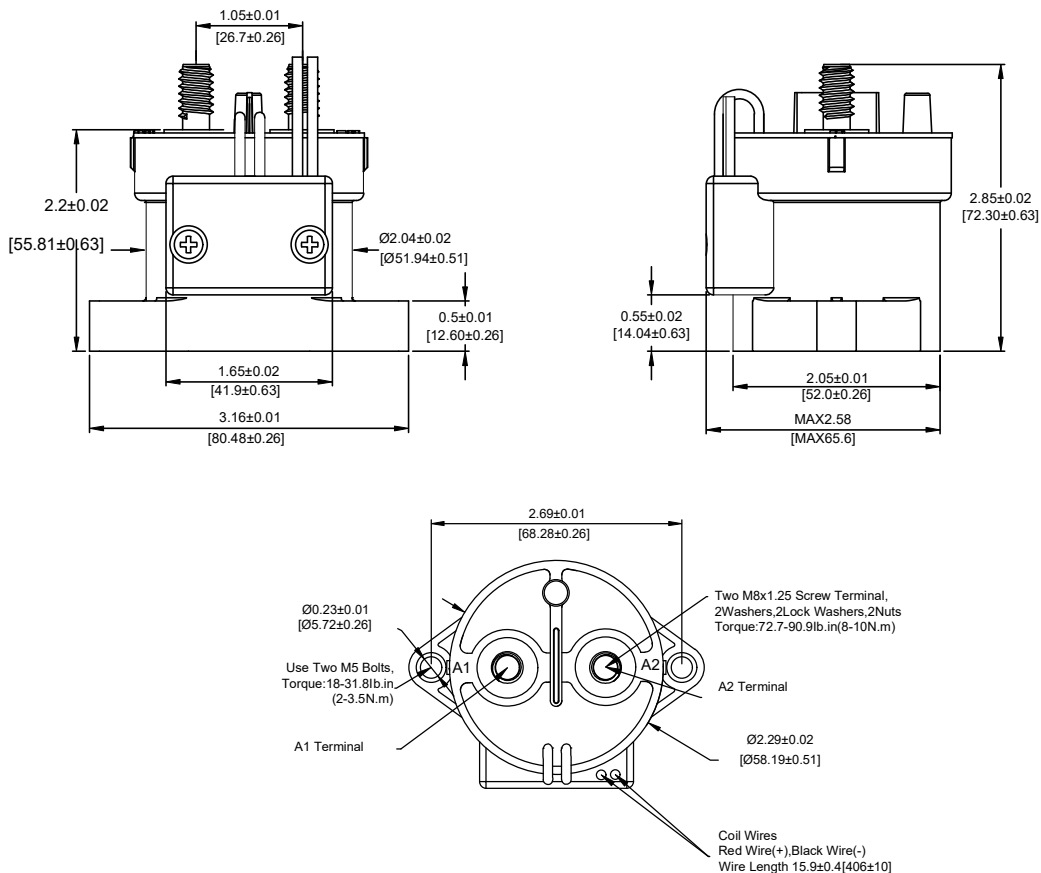

Outline Dimensions (mm)

Side Mount

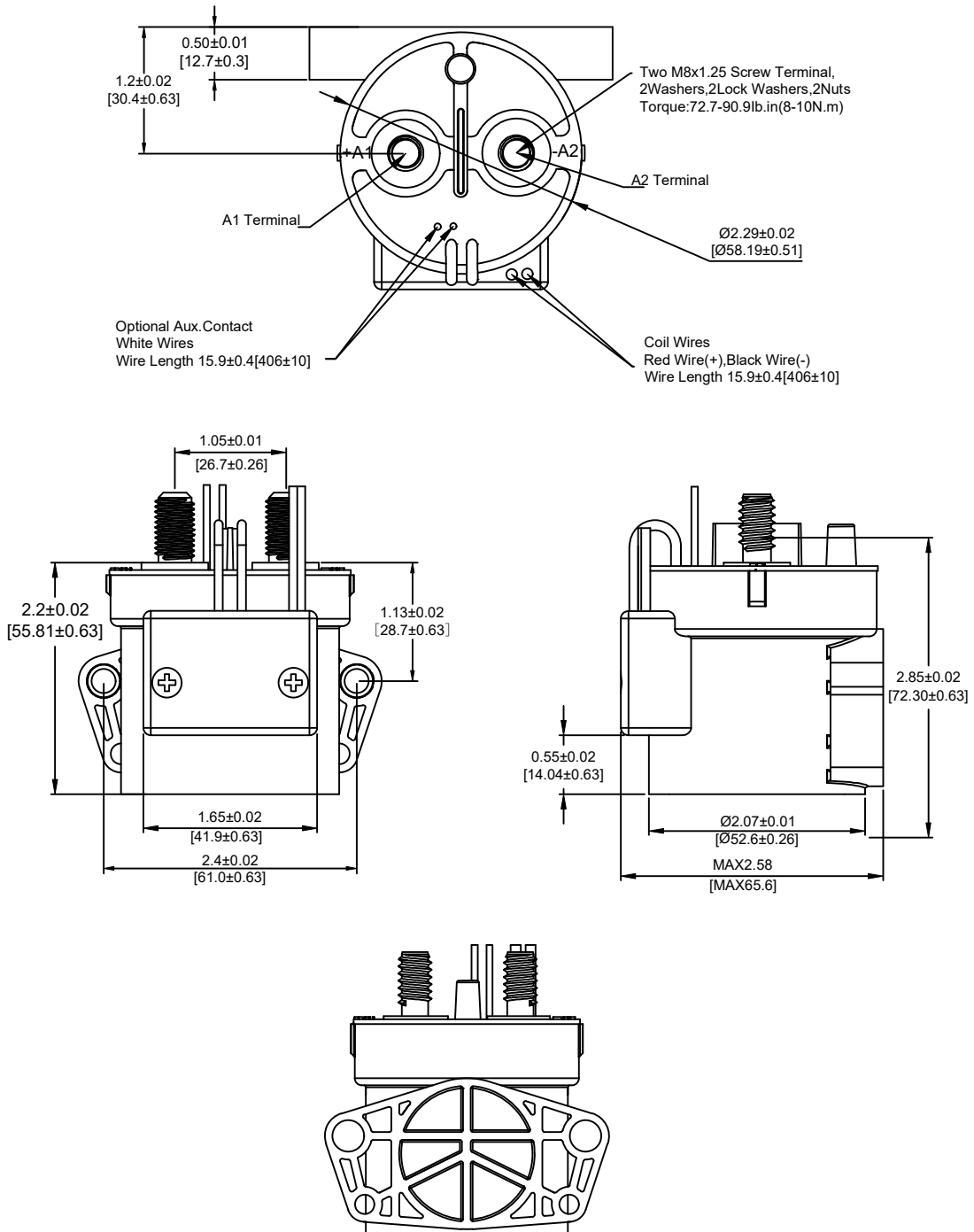

*Note: The wire size is 22 AWG.

Application Notes

1. To prevent loosening, split washers should be used whenever the contactor is installed. All terminals or copper conductors must directly contact the contractor's main terminals. Please control the nut-tightening torque of each part within the specified range in the table below. If the torque exceeds the recommended range, it may cause damage to the sealed cavity and thread damage.
 - Contact torque: 70-90 lb. in. (8-10 N.m)
 - Mounting torque: 15-30 lb. in. (1.7-3.3 N.m)
2. Products with polarity marked on the load end must be used correctly according to the product label. When the load connection polarity is reversed, the electrical characteristics promised in this manual cannot be guaranteed.
3. Products with a coil economizer are already equipped with back EMF circuits, so there is no need to use surge protectors. Avoid installing the contactor in a robust magnetic field environment (near transformers or magnets) and avoid placing the contactor near objects with heat radiation.
4. When continuous current is applied to the relay contacts, the coil is turned on immediately after the power is cut off. At this time, as the coil's temperature increases, the coil's resistance will also increase, which will increase the pull-in voltage of the product, which may result in exceeding the rated pull-in voltage. In this case, the following measures should be taken to reduce the load current: limit the continuous power-on time or use a coil voltage higher than the rated pull-in voltage.
5. When the voltage applied to the coil exceeds the maximum allowable applied voltage, the coil temperature may rise, leading to coil damage and inter-layer short circuit.
6. The rated values in the contact parameters are values for a resistive load. When using an inductive load with
7. $L/R > 1\text{ms}$, please connect a surge current protection device to the inductive load in parallel. If measures are taken, the electrical life may be maintained, and the continuity may be suitable. Please consider sufficient margin space in the design.
8. Drive power must be greater than coil power, or it will reduce performance capability.
9. Please do not allow debris and oil to adhere to the main terminals. Ensure that the central terminals are in reliable contact with the load conductor; otherwise, the temperature rise of the terminal/conductor connection may be too high due to the excessive contact resistance.
10. The load conductor must have the corresponding current load capacity and heat dissipation capacity (it is recommended to use a copper bar with a 50mm²) to prevent overheating and affecting the life of the contactor.
11. It's only possible to determine some of the performance parameters of contactors in each specific application; therefore, customers should choose the products that match them according to their conditions of use. If in doubt, contact Altran. The customer will be responsible for validating that the products meet their application.
12. Do not use if dropped.
13. Altran reserves the right to make changes as needed. Customers should reconfirm the specification's contents or ask us to supply a new specification if necessary.