

RP0402ZZ-XXXXWN-2Q Features:

- Wraparound Terminals
- Solder, Epoxy or Wirebond Attachment
- Customer Defined Testing Available
- RoHS Compliant or SnPb Available
- Tape & Reel or Waffle Pack Available (Standard is bulk)

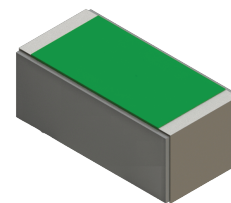

RP0402ZZ-XXXXWN-2Q Parameters:

Resistance Range:	10Ω - 1KΩ
Rated Power:	1W*
Construction:	Thick Film on AIN
Operating Temperature:	-55 to +150°C

Actual Size

* Rating based on ≤100°C constant baseplate temperature

RP0402ZZ-XXXXWN-2Q Dimensions:

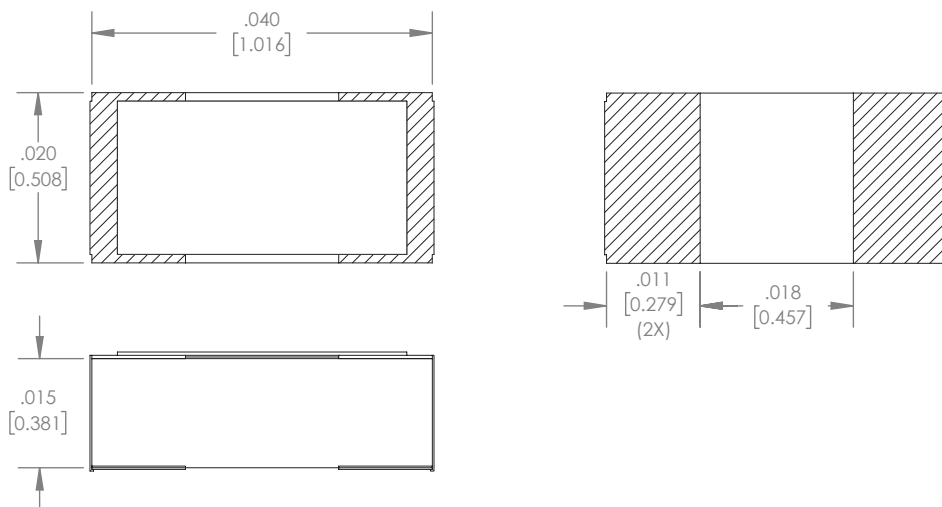

RP0402ZZ-XXXXWN-2Q Power Derating Curve

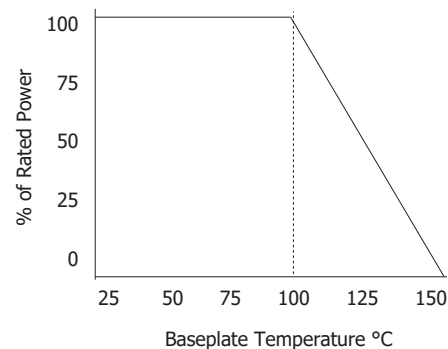

Dimensions in inches [mm]
 Tolerance is ± 0.005 [0.127]
 unless otherwise stated

Ordering Information:

Example Part Number: RP0402CT-50R0JN-2Q

RP	0402	ZZ	-	XXXX	W	N	-	2Q	UU
Prefix for Wraparound Resistor	Size	Value Code Examples		Tolerance	Normal Inspection	Substrate		Package	
	0402	10R0 - 10Ω 1000 - 100Ω 1001 - 1KΩ		F - 1% G - 2% J - 5%	Contact factory for additional options	2Q - 0.015" AIN		Blank - Bulk TR - Tape and Reel WP - Waffle Pack	
Terminal Metallization	RoHS	Magnetic	Solder	Epoxy	Wirebond				
CT - 100% Matte Tin over Nickel over Silver	Yes	Yes	Yes	No	No				
CB - Sn62 over Nickel over Silver	No	Yes	Yes	No	No				
CC - 100% Matte Tin over Copper	Yes	No	Yes	No	No				

Barry Industries reserves the right to change part number and/or process without notification.

RP0402ZZ-XXXXWN-2Q Reliability Specifications:

Parameter:	Test Condition:	Results:
Short Time Overload	Apply 1.1x Rated Power for 5 Seconds.	≤ 5.0% Resistance Shift
Rated Load Life	Apply 1/2 Power Under 40°C ±2°C 90 Minutes on/ 30 Minutes off. Repeat for 100 hours	≤ 5.0% Resistance Shift
Moisture Resistance	MIL-PRF-55342 para 4.8.9 95% RH, 25°C - 65°C	≤ 5.0% Resistance Shift
Resistance to Soldering Heat	MIL-STD-202 Method 210 and MIL-PRF-55342 Para 4.8.8.1	≤ 5.0% Resistance Shift
Resistance to Bonding Exposure	MIL-PRF-55342 Para 4.8.8.2	≤ 5.0% Resistance Shift
Solderability	MIL-PRF-55342 Para 4.8.12	>95% Covered
High Temperature Storage	125°C ±2°C for 500 Hours	1.) ≤ 5.0% Resistance Shift 2.) No Significant Abnormality (Visual)
Thermal Shock	-65°C to +150°C 30 Minutes Dwell, 5 Cycles	1.) ≤ 5.0% Resistance Shift 2.) No Significant Abnormality (Visual)

Barry Industries reserves the right to change part number and/or process without notification.