

PROPRIETARY AND CONFIDENTIAL
 THE INFORMATION CONTAINED HEREIN IS THE SOLE PROPERTY OF
 VECTOR INJECTION TECHNOLOGIES, INC. ANY REPRODUCTION OR
 DISSEMINATION OF THIS INFORMATION WITHOUT THE WRITTEN
 CONSENT OF VECTOR INJECTION TECHNOLOGIES, INC. IS
 STRICTLY PROHIBITED. VECTOR INJECTION TECHNOLOGIES, INC.
 & TECHNOLOGIES ARE REGISTERED.

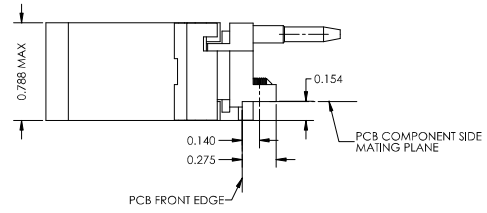

TOP HANDLE DETAIL

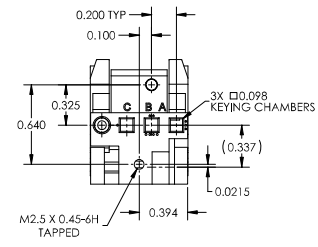
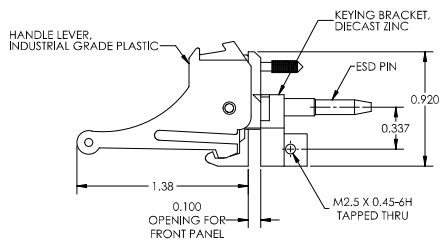
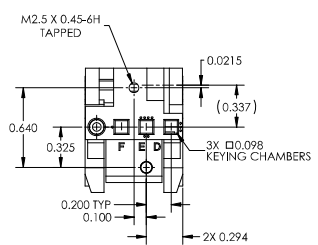
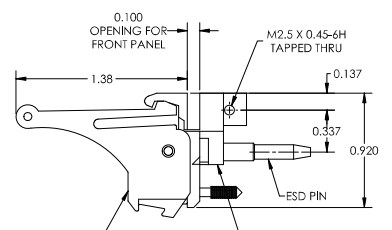
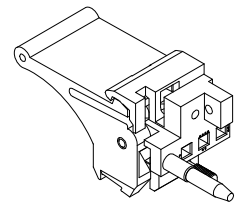
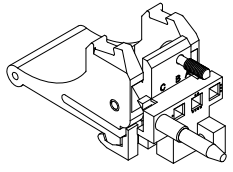
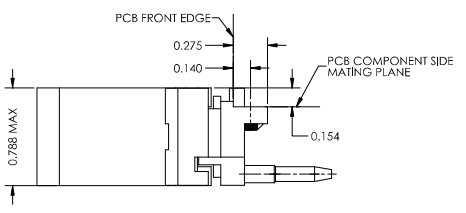

BOTTOM HANDLE DETAIL

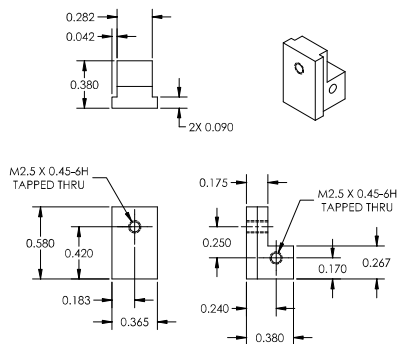

**L-BRACKET DETAIL
 (PART OF 90100016)**
 CENTER L-BRACKET MOUNTING IS OPTIONAL AND THAT IT CAN BE ORIENTED UP OR DOWN. USER MUST FIND THE FRONT PANEL LOCATION DEPENDING ON THE POSITION OF L-BRACKET AND WHICH HOLE WILL BE USED.

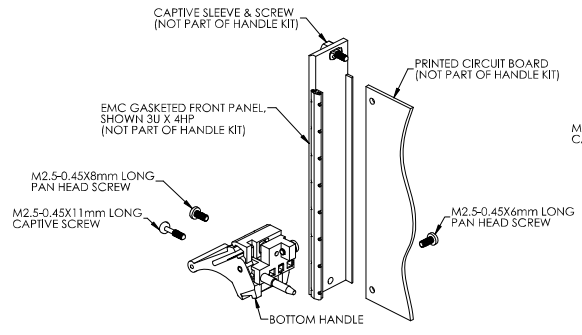

**EXPLODED VIEW
 3U FRONT PLUG-IN CARD ASSEMBLY**

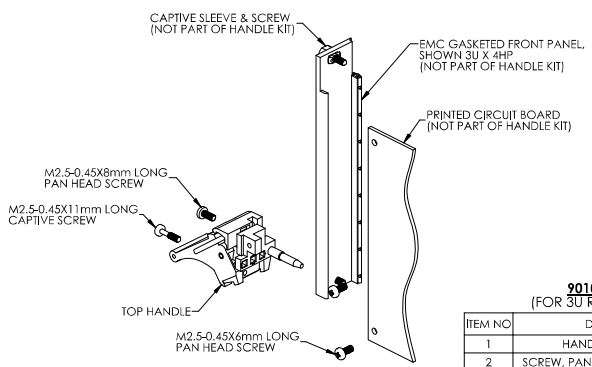

**EXPLODED VIEW
 3U RTM PLUG-IN CARD ASSEMBLY**

**90100002 PARTS LIST
 (FOR 3U RTM PANEL ASSEMBLY)**

ITEM NO	DESCRIPTION	QTY	U/M
1	HANDLE, TOP, TYPE IV	1	EACH
2	SCREW, PAN HEAD, M2.5-0.45X6mm	1	EACH
3	SCREW, PAN HEAD, M2.5-0.45X8mm	1	EACH
4	SCREW, CAPTIVE, M2.5-0.45X11mm	1	EACH

REV	DESCRIPTION	DATE	APPROVED
REV A	RELEASE	05/27/15	
REV B	ADD PARTS 9010002 FOR 3U PANELS	06/04/17	
REV C	ADD NOTE FOR ORIGINAL CENTER L-BRACKET	10/23/18	
REV D	UPDATE PARTS LIST FOR 9010002	12/04/20	

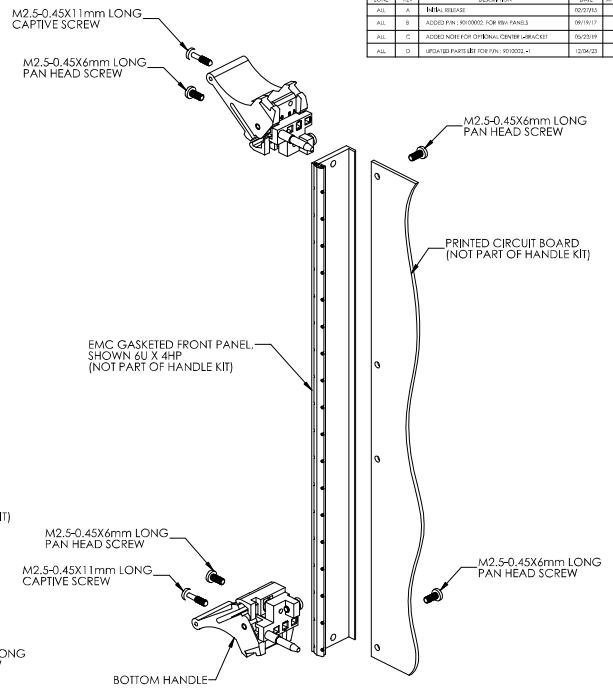

**EXPLODED VIEW
 6U OR 9U PLUG-IN CARD ASSEMBLY**

**90100016 PARTS LIST
 (FOR 6U OR 9U FRONT PANEL ASSEMBLY)**

ITEM NO	DESCRIPTION	QTY	U/M
1	HANDLE, BOTTOM, TYPE IV	1	EACH
2	HANDLE, TOP, TYPE IV	1	EACH
3	L-BRACKET, METAL (OPTIONAL)	1	EACH
4	SCREW, PAN HEAD, M2.5-0.45X6mm	5	EACH
5	SCREW, CAPTIVE, M2.5-0.45X11mm	2	EACH
6	SCREW, FLAT HEAD, M2.5-0.45X8mm	1	EACH

**90100002-1 PARTS LIST
 (FOR 3U FRONT PANEL ASSEMBLY)**

ITEM NO	DESCRIPTION	QTY	U/M
1	HANDLE, BOTTOM, TYPE IV	1	EACH
2	SCREW, PAN HEAD, M2.5-0.45X6mm	1	EACH
3	SCREW, PAN HEAD, M2.5-0.45X8mm	1	EACH
4	SCREW, CAPTIVE, M2.5-0.45X11mm	1	EACH

DESIGNER: []	CHECKED: []	DATE: []		VECTOR INJECTION TECHNOLOGIES, INC. 25000 RIVERVIEW DRIVE, SUITE 100 RIVERVIEW, CA 94583-1000 TEL: 925.835.1000 FAX: 925.835.1001 WWW.VECTORINJECTION.COM
DRAWN: []	ENG APPR: []	DATE: []		
DATE: []	SCALE: []	REV: []	INJECTOR/EJECTOR HANDLE, TYPE IV 1101.10	
COMMENTS: []			SHEET NO. [] SCALE: 1:1 [] CAGE CODE: 18299 [] SHEET 1 OF 1 []	REV []