

583718-9 ✓ ACTIVE

AMP | AMP Twin-Leaf

TE Internal #: 583718-9

Housing, Receptacle, Wire-to-Board, 22 Position, .1 in [2.54 mm]

Centerline, Crimp, 2 Row, Black, Mating Retention, AMP Twin-Leaf

[View on TE.com >](#)



Connectors > PCB Connectors > Wire-to-Board Connectors > Wire-to-Board Connector Assemblies & Housings



Connector Product Type: **Housing**

Connector & Housing Type: **Receptacle**

Connector System: **Wire-to-Board**

Number of Positions: **22**

Centerline (Pitch): **2.54 mm [.1 in]**

Features

Product Type Features

Connector Product Type	Housing
Connector & Housing Type	Receptacle
Connector System	Wire-to-Board
Connector & Contact Terminates To	Printed Circuit Board

Configuration Features

Number of Dual Positions	22
Number of Positions	22
Number of Rows	2

Body Features

Primary Product Color	Black
-----------------------	-------

Contact Features

Contact Current Rating (Max)	5 A
------------------------------	-----

Termination Features

Termination Method to Wire & Cable	Crimp
------------------------------------	-------



Mechanical Attachment

Strain Relief	Without
PCB Mount Retention	Without
Panel Mount Feature Type	Mounting Ears
Mating Retention	With
Connector Mounting Type	Board Mount

Housing Features

Housing Material	Polyester GF
Centerline (Pitch)	2.54 mm[.1 in]

Dimensions

	.75 in
--	--------

Usage Conditions

Operating Temperature Range	-55 – 105 °C[-67 – 221 °F]
-----------------------------	----------------------------

Operation/Application

Circuit Application	Power & Signal
---------------------	----------------

Industry Standards

Glow Wire Rating	Standard Part - Not Glow Wire
UL Flammability Rating	UL 94V-0

Packaging Features

Packaging Quantity	125
Packaging Method	Box

Product Compliance

[For compliance documentation, visit the product page on TE.com>](#)

EU RoHS Directive 2011/65/EU	Compliant
EU ELV Directive 2000/53/EC	Compliant
China RoHS 2 Directive MIIT Order No 32, 2016	No Restricted Materials Above Threshold
EU REACH Regulation (EC) No. 1907/2006	Current ECHA Candidate List: JAN 2024 (240) Candidate List Declared Against: JAN 2024 (240) Does not contain REACH SVHC
Halogen Content	Not Low Halogen - contains Br or Cl > 900 ppm.



Solder Process Capability

Not applicable for solder process capability

Product Compliance Disclaimer

This information is provided based on reasonable inquiry of our suppliers and represents our current actual knowledge based on the information they provided. This information is subject to change. The part numbers that TE has identified as EU RoHS compliant have a maximum concentration of 0.1% by weight in homogenous materials for lead, hexavalent chromium, mercury, PBB, PBDE, DBP, BBP, DEHP, DIBP, and 0.01% for cadmium, or qualify for an exemption to these limits as defined in the Annexes of Directive 2011/65/EU (RoHS2). Finished electrical and electronic equipment products will be CE marked as required by Directive 2011/65/EU. Components may not be CE marked. Additionally, the part numbers that TE has identified as EU ELV compliant have a maximum concentration of 0.1% by weight in homogenous materials for lead, hexavalent chromium, and mercury, and 0.01% for cadmium, or qualify for an exemption to these limits as defined in the Annexes of Directive 2000/53/EC (ELV). Regarding the REACH Regulation, the information TE provides on SVHC in articles for this part number is based on the latest European Chemicals Agency (ECHA) 'Guidance on requirements for substances in articles' posted at this URL: https://echa.europa.eu/guidance-documents/guidance-on-reach

Also in the Series | AMP Twin-Leaf

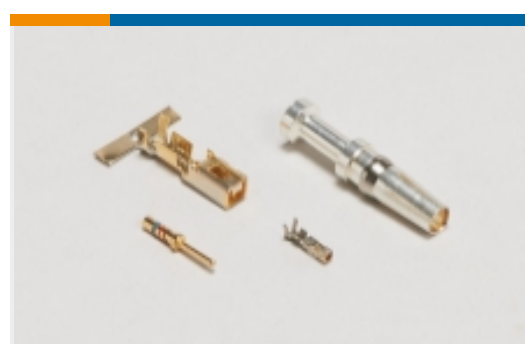

Connector Contacts(15)



Insertion & Extraction Tools(1)

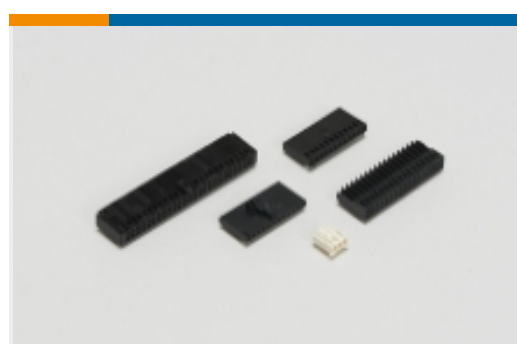

Wire-to-Board Connector Assemblies & Housings(17)

Customers Also Bought



TE Part #1423967-1
T92P7D52-24



TE Part #1-353908-3
CT REC HSG 13P CRIMP TYPE WHIT



TE Part #2-520407-2
ULTRA-FAST 250 ASY REC 22-18 TPBR

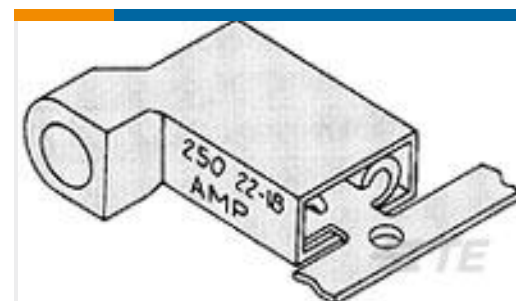

TE Part #2-520337-2
ULTRA-FAST 187 ASY REC 22-18 TPBR

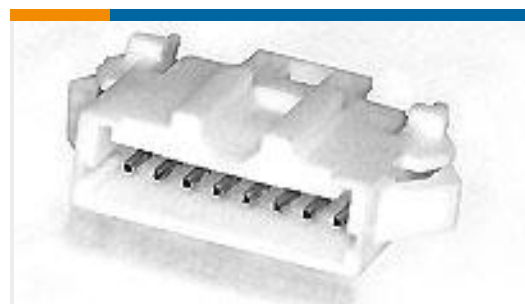

TE Part #1-292215-8
MINI CT SGL RELAY 18P NAT

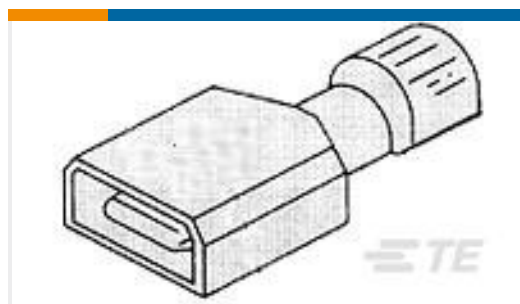

TE Part #2-521144-2
ULTRA-FAST 250 ASY TAB 22-18 TPBR

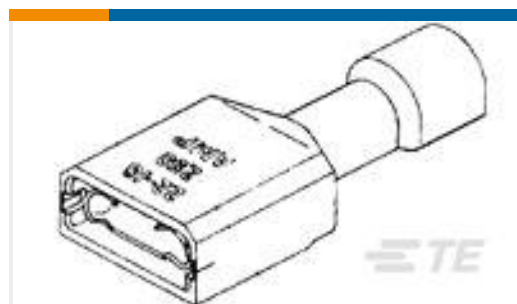

TE Part #2-520181-2
ULTRA-FAST 187 ASY REC 22-18 AWG TPBR



TE Part #36161
TERMINAL,PIDG R 12-10 10



TE Part #470037-000
CWT-9002

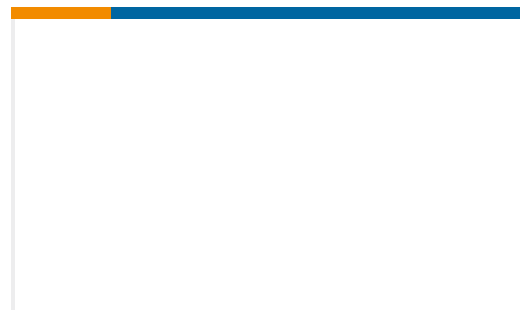

TE Part #1-1892082-9
PWR CONT SOLDER TAIL RA HRD
MULTI

Documents

Product Drawings

[TW-LEAF CRP HSG 22 POS 100 C/L](#)

English

CAD Files

Customer View Model

[ENG_CVM_CVM_583718-9_AS.2d_dxf.zip](#)

English

[3D PDF](#)

3D

Customer View Model

[ENG_CVM_CVM_583718-9_AS.3d_igs.zip](#)

English

Customer View Model

[ENG_CVM_CVM_583718-9_AS.3d_stp.zip](#)

English

By downloading the CAD file I accept and agree to the [Terms and Conditions](#) of use.

Product Specifications

[Product Specification](#)

English

[Product Specification](#)

English

Instruction Sheets

[Instruction Sheet \(U.S.\)](#)

English

Agency Approvals

[UL](#)

English