

SECTION A-A

CORE (28A4155-000)

FERRITE CORE DIMENSIONS (SPEC): mm [in]

A	25.00 [.984]	±	REF.
B	15.00 [.591]	±	REF.
C	12.00 [.472]	±	REF.
D	12.50 [.492]	±	REF.

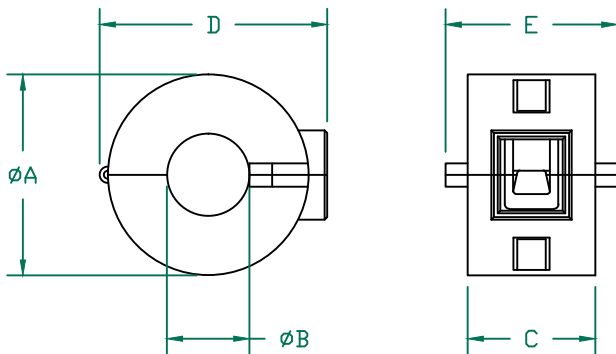

CASE (A4155-0C2)

CASE DIMENSIONS (SPEC): mm [in]

A	28.80 [1.134]	±	0.40 [.016]
B	13.60 [.535]	±	0.40 [.016]
C	15.40 [.606]	±	0.30 [.012]
D	33.20 [1.307]	±	0.50 [.020]
E	21.80 [.858]	±	0.60 [.024]



IMPEDANCE (Z)			
Frequency	25 MHz	100 MHz	300 MHz
Nominal (REF)	50 Ω	120 Ω	230 Ω
Minimum	- Ω	96 Ω	- Ω

Z vs. FREQUENCY
(REF. ONLY)

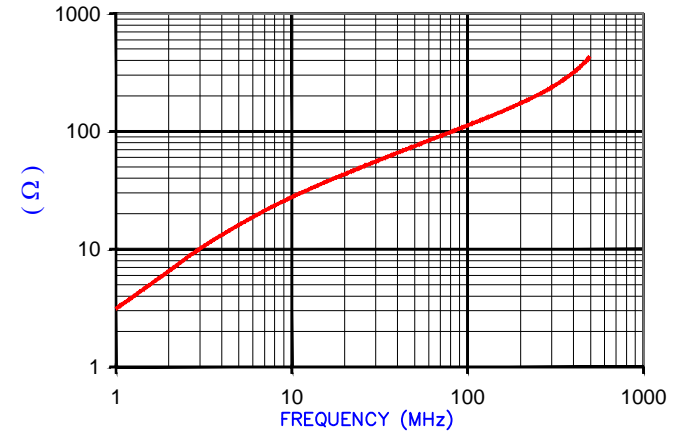

AGILENT E4991A Impedance/Material Analyzer
HP 16092A-Test Fixture REF 3147

NOTES:

- CASE UL FLAMMABILITY RATING: 94 V-0
- ASSEMBLED PART #: 28A4155-0A2
- FOR CORE DIMENSIONS SEE STEWARD P/N 28A4155-000.
- FOR CASE DIMENSIONS SEE STEWARD P/N A4155-0C2.
- CASE COLOR: -0A2 BLACK CASE.
- COSMETIC SPECIFICATION REFER TO WI-QA-038.

DIMENSIONS ARE IN mm [INCHES].				This print is the property of Laird Tech. and is loaned in confidence subject to return upon request and with the understanding that no copies shall be made without the written consent of Laird Tech. All rights to design or invention are reserved.				
REV	DESCRIPTION	DATE	INT					
J	UPDATE COMPANY LOGO ,ADD NOTE 6	08/23/14	QIU	PROJECT/PART NUMBER: 28A4155-0A2		REV	PART TYPE:	DRAWN BY:
H	UPDATE CASE TOLERANCES UPDATE COMPANY LOGO	05/08/08	TMB			J	FERRITE SNAP-ON	TMB
G	UPDATE Z SPEC & COMPANY LOGO	06/26/07	JRK	DATE: 06/27/01		SCALE:	MATERIAL:	
F	CHG Z SPECS@100MHZ ADD TEST REF#	12/21/04	JRK			NTS	Ferrite	
E	CHANGE P/N FROM -0A* TO -0A2 REVISE NOTES 2, 4, & 5	08/15/03	TMB	CAD # 28A4155-0A2-J		TOOL #		
D	CHANGE PRINT FORMAT CHANGE Z SPECS AND ADD CURVE REVISE NOTE 3,4,& 5 REMOVE CORE DIMS E, F, G, & DET. "A"	07/01/03	TMB			-		
REV	DESCRIPTION	DATE	INT					