

Price Index



Series 04

Special Features / Options



IPA Qualification Certificate:
Cleanroom test upon request



ESD Classification:
Electrically conductive ESD/
ATEX version upon request



Flammability Class
VDE 0304 IIC UL94 HB

Assembly Tips



Easy to assemble and disassemble

Usage Guidelines



- If quieter operation is required
- If cost is a factor
- If snap-open links are not necessary



- If snap-open links are required
 - Series 047 "Zipper"
- If quick insertion of cables with preassembled connector is required
 - Series E04 E-Z Chain

Features & Benefits

- 1 Very lightweight - low price
- 2 One-piece, non snap-open e-chain®
- 3 Small e-chain® -
interior dimensions .28" x .28" (7 x 7 mm)
- 4 Dirt-repellant exterior



Order Example: Complete e-chain®

Please indicate chain length or number of links. Example:

3.28 ft (1 m) 04-07-038-0

e-chain®

1 Set 040-07-12

Mounting Bracket

e-chain system® E2 Micro Series 04 Installation Dimensions



Short travel, unsupported length

- FL_B = unsupported with permitted sag
 - FL_G = unsupported with straight upper run
- Further information ► Design, Chapter 1

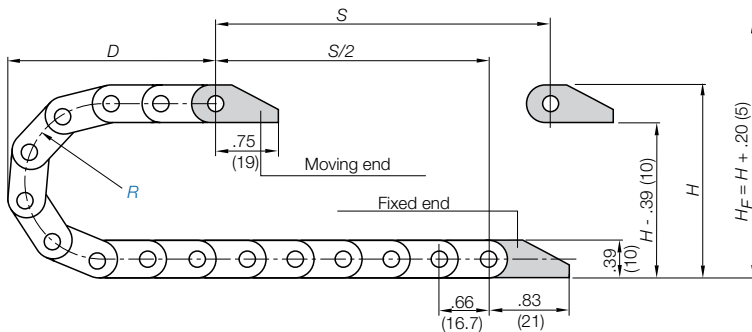
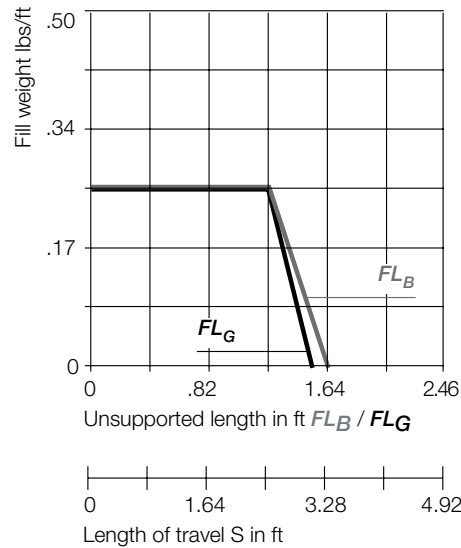
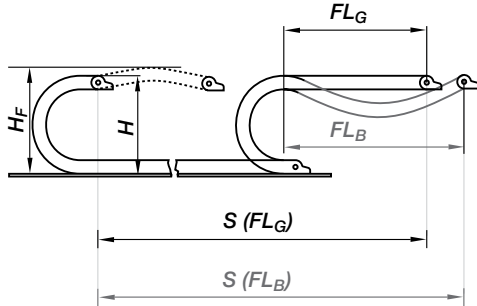

Pitch per link = .66" (16.7 mm)
 Links per ft (m) = 18.28 (60)
 For center mount applications:
 Chain length = $\frac{S}{2} + K$

The required clearance height: $H_F = H + .20 \text{ in. (5 mm)}$ (with .067 lbs/ft (0.1 kg/m) fill weight).
 Please consult igus® if space is particularly restricted.

R	.59 (015)	.71 (018)	1.10 (028)	1.50 (038)	1.89 (048)
H	1.57 (40)	1.81 (46)	2.60 (66)	3.39 (86)	4.17 (106)
D	1.77 (45)	1.89 (48)	2.28 (58)	2.68 (68)	3.07 (78)
K	3.35 (85)	3.54 (90)	4.92 (125)	6.10 (155)	7.28 (185)

Short Travels - Unsupported



Unsupported e-chains® feature positive camber over short travels. This must be accounted for when specifying the clearance height. Please refer to **Installation dimensions** for further details.

Legend

- S = Length of travel
- R = Bending radius
- H = Nominal clearance height
- D = Overlength e-chain® radius in final position
- $K = \pi \cdot R + \text{safety buffer}$
- H_F = Required clearance height



PDF: igus.com/e-chain-pdfs
 Product information: igus.com/e-chains



Speed / acceleration FL_G	max. 65.6 ft/s (20 m/s) / max. 656 ft/s ² (200 m/s ²)
Speed / acceleration FL_B	max. 9.84 ft/s (3 m/s) / max. 19.69 ft/s ² (6 m/s ²)
Gliding speed / acceleration (maximum)	max. 9.84 ft/s (3 m/s) / max. 32.8 ft/s ² (10 m/s ²)
Material - permitted temperature	igumid G / -40°F (-40°C) up to +248°F (+120°C)
Flammability Class, igumid G	VDE 0304 IIC UL94 HB

Technical Data



Details of material properties

► Chapter 1

Series 04 - e-chain® non snap-open

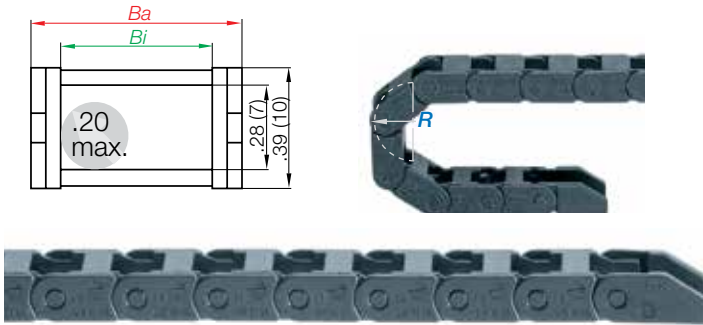

Part Number Structure

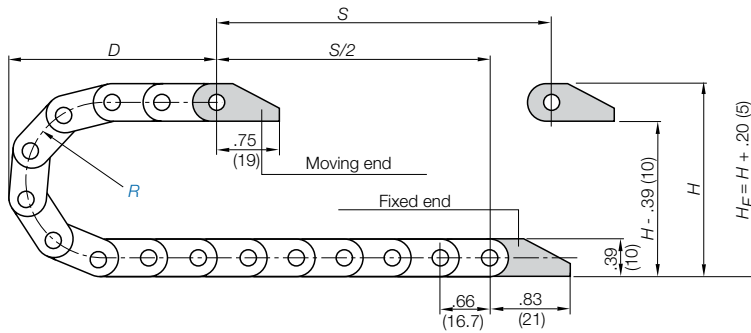
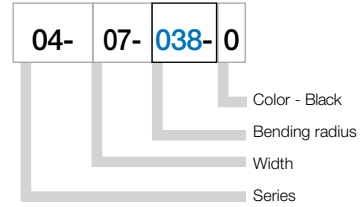

Supplement part number with required radius. Example: 04-07-**038**-0
Pitch: .66 in. (16.7 mm) per link links/ft (m) = 18.28 (60)

Part Number	<i>Bi</i> in. (mm)	<i>Ba</i> in. (mm)	Weight lbs/ft (kg/m)
04-07- <input type="text"/> -0	.28 (7)	.47 (12)	≈ 0.047 (0.07)
04-10- <input type="text"/> -0	.39 (10)	.59 (15)	≈ 0.053 (0.08)
04-16- <input type="text"/> -0	.63 (16)	.83 (21)	≈ 0.060 (0.09)
04-20- <input type="text"/> -0	.79 (20)	.98 (25)	≈ 0.067 (0.10)
04-30- <input type="text"/> -0	1.18 (30)	1.38 (35)	≈ 0.073 (0.11)

Choose from the radii below for all of the above sizes

Radius (mm) Example: 04-07-**038**-0

	015	018	028	038	048
R	.59 (015)	.71 (018)	1.10 (028)	1.50 (038)	1.89 (048)
H	1.57 (40)	1.81 (46)	2.60 (66)	3.39 (86)	4.17 (106)
D	1.77 (45)	1.89 (48)	2.28 (58)	2.68 (68)	3.07 (78)
K	3.35 (85)	3.54 (90)	4.92 (125)	6.10 (155)	7.28 (185)

0=Standard color black. For other colors see Chapter 1

e-chain system® E2 Micro Series 04 Mounting Brackets



Polymer, one-piece

- One-piece mounting bracket
- Corrosion resistant
- Available preassembled
- Inner and outer attachment possible

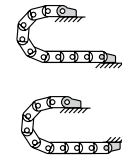
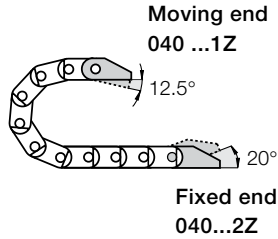

Possible installation configurations -

Part Number Structure

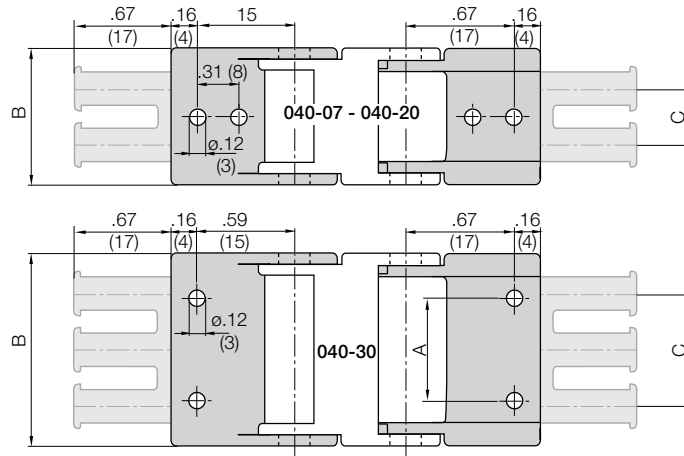
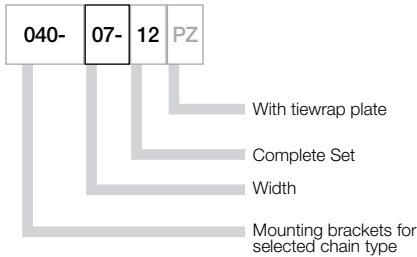

Full set, for both ends:

040-07-12-PZ Full set, each part with pin/bore

Single-part order:

040-07-1-PZ Mounting bracket with bore

040-07-2-PZ Mounting bracket with pin

Chain Type	Part No.	Part No.	Dimension A		Dimensions B		Dimension C		Number of Teeth
	Full set without Tiewrap Plate	Full set with Tiewrap plate	in.	(mm)	in.	(mm)	in.	(mm)	
04-07	040-07-12	040-07-12PZ	—	—	.47	(12)	—	—	1
04-10	040-10-12	040-07-12PZ	—	—	.59	(15)	—	—	1
04-16	040-16-12	040-07-12PZ	—	—	.83	(21)	.39	(10)	2
04-20	040-20-12	040-07-12PZ	—	—	.98	(25)	.39	(10)	2
04-30	040-30-12	040-07-12PZ	.87	(22)	1.38	(35)	.79	(20)	3

Additional accessories



Quicksnap - the complete, detachable mounting unit, upon request
Only available for the 040-07 e-chain - **Part No. 040-07-QS**

