

# CH4000A/E/U/X



## Desktop Smart Charger Instructions for use

The CH4000 is a standalone desktop smart, standard battery charger. It works with all Inspired Energy® brand “N” Series smart standard packs irrespective of size, shape, voltage, cell chemistry or capacity.

### What’s in the box?

1. One CH4000 desktop charger
2. Three plastic spacers to modify the battery bay to suit your battery size
3. One 24V 2.5A DC power supply with universal mains input
  - N. American chargers (CH4000A) are packed with a US 3-pin mains cord
  - European chargers (CH4000E) have a European 2-pin + ground recess mains cord
  - UK chargers (CH4000U) are packed with a UK 3-pin mains cord
  - CH4000X is not packed with a mains cord

### Safety:

1. Do not expose the charger or power supply to water or liquids; the case is not sealed.
2. Do not open the charger or power supply case, no user serviceable parts are inside.
3. Do not cover the air vent or obstruct the airflow, this will cause overheating.
4. Use only the manufacturer’s power supply and observe terminal polarity.
5. Place the charger in a cool spot, away from external heat sources.

## Using your Charger:

Place the charger on a flat, level surface away from sources of heat and moisture. Plug the DC connector from the power supply into the back of the charger and connect the power supply to the mains AC supply using the cable supplied. All LEDs illuminate for two seconds on power up.

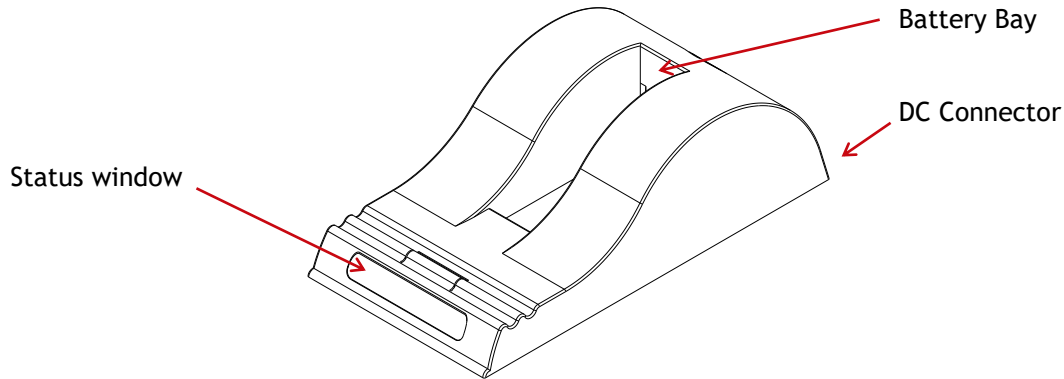

## Using the Plastic Spacers:

Plastic spacers are supplied to assist in the correct insertion of all of the different sizes of smart standard packs. To insert a spacer, place the bottom of the spacer in the rear corner of the battery bay. Place a thumb on the top of the spacer and push it firmly towards the back of the charger. Correct insertion should be accompanied by a click as the guides lock into place. The cross reference of spacers to batteries is given below:

Thick “L” shaped spacer: NC2560, NI1030 & ND2017 Style

Thin “L” shaped spacer: NJ1020 & NI2020 Style

Flat spacer: NL2020 & NL2024

No spacer is required for the 203x, 204x or 205x ranges of batteries.

## Charging:

Place the battery into the battery bay ensuring that the 5-way connector is fully seated. The LEDs in the status window will provide status information and the charger will automatically begin charging.

## LED Indication:

The status of the battery is indicated by the LEDs visible in the status window:

- \* Green flashing: Battery charging
- Green solid: Battery fully charged
- Red solid: Error

## Recharge Time:

Different battery packs will require differing recharge times. The times given below are for a full charge from 0% to 100% state of charge. They are valid for all variants and custom hybrids of each battery model. (For example, the NJ1020HP has the same recharge time as the NJ1020.)

Battery Chemistry	Battery Model	Recharge Time From Empty (hours)
NiMH	NI1030, NJ1020	1.5
	NC2560, NL2024, NL2044, NL2054	3
Li-ion	NB2037, NC2040, ND2054, ND2034, ND2057, ND2037, NF2040, NF2030, NH2054, NI2020, NI2040, NL2020, NL2050	3.5
	ND2053, NF2047	4
	ND2017	6
	NH2057	7

## What are the SMBus and the SBS?

The Smart Battery System defines the parameters that are stored by a compliant battery. These parameters include full battery status and fuel gauging information. The System Management Bus is the language by which these parameters are communicated between the battery, the charger and the host device. For full details of the SBS information available from your battery please refer to the battery specification sheet available at [www.inspired-energy.com](http://www.inspired-energy.com).

## How does the charger know what charge to deliver?

The CH4000 charger is capable of sensing and delivering an appropriate charge to all Inspired Energy NiMH and Li-ion standard battery packs. Upon inserting the battery into the charger, the battery communicates to the charger over the SMBus telling the charger what type of cell chemistry it is and what type of charge it needs. The CH4000 then configures its output to provide the charge requested by the battery. If no SMBus communications are issued from the battery, the charger interrogates the thermistor/resistor I.D. pin on the battery terminal and delivers an appropriate charge.

## Compatibility:

The CH4000 is fully compatible with all Inspired Energy® brand “N” Series standard battery packs and their custom hybrids. For optimum results we recommend using only Inspired Energy® brand smart batteries. For a full list of all compatible Inspired Energy batteries, please visit:

[www.inspired-energy.com](http://www.inspired-energy.com)

## CH4000A/E/U/X Specification Summary

Weight:	235g / 8oz (Excluding AC cable & Power supply)
Height:	58mm / 2¼"
Length:	180mm / 7"
Width:	92mm / 3½"
Mating Connector:	5-blade standard battery connector
Communications Compliances:	System Management Bus Rev 1.0, Smart Battery Data Specification Rev 1.0 and Smart Battery Charger Specification Rev 1.0 compliant
Power Supply:	100-250VAC, 24V, 2.5A DC, 119x38x60mm, 500g / 18oz UL listed, CE Compliant, CEC Compliant
Mains Cord:	CH4000A - 110V N. American 3-pin connector CH4000E - 220V European 2-pin connector with ground recess CH4000U - 240V UK 3-pin connector CH4000X - No AC power cord supplied

