

ITEM NO.	PART NUMBER	DESCRIPTION	QTY.	COMPONENT NOTES
1	50-00057	Connector, dc jack, 3.5x1.35xL16.5 mm, molding style	1	
2	30-00692	Wire, 2C TS, 24 AWG, UL2464, 300V, 80C, 4.0 mm, VW-1, PVC	1	
3	24-00184	Overmold, dc jack, 3.5 mm, Tensility	1	black, PVC

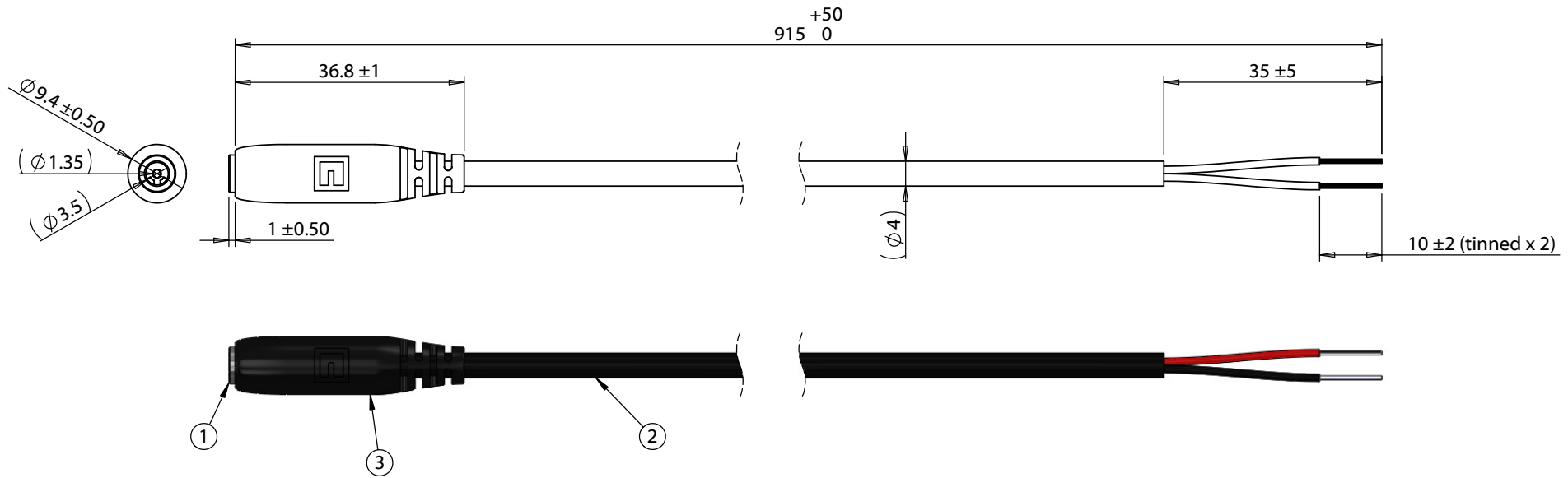

**Notes:**  
Functionally equivalent components may be substituted

Electrical requirements: 4.5 A, 48 Vdc

Wiring Diagram	
50-00057	wire color
center	red
sleeve	black

Revision:	Date:	Description:	Prepared:	Notes: RoHS compliant Function test: no open, no short circuit, no intermittent	<h1>TENSILITY</h1> <p>tel 1.541.323.3228 800 877.670.7118 fax 1.541.323.4202 web tensility.com</p>	
A	9/13/2016	Initial release	Verified:			
A1	2/15/2019	corrected overmold dimension	Dimensions are in millimeters. Tolerances: X: ± 0.5 mm X.X: ± 0.3 mm X.XX: ± 0.05 mm	Description: Cable, 915 mm, 3.5x1.35 mm 50-00057 dc jack to stripped tinned, 24 AWG, 30-00692 wire	Size: A	Part number: 10-02250
				Scale: 1:1		Sheet 1 of 1

5 4 3 2 1